



DOC023.52.03252

3798-S sc **Digital inductive conductivity sensor**

User Manual

08/2022, Edition 3

Table of contents

Section 1 Technical data	3
1.1 Technical data for the 3798-S sc conductivity sensor	3
Section 2 General information	5
2.1 General handling instructions	5
2.2 Applications	5
2.3 Basic principles.....	5
2.4 Measuring principle	6
Section 3 General safety instructions	7
3.1 Possible sources of hazards.....	7
3.2 Safety symbols	7
3.3 Electrical safety measures and fire prevention measures	8
3.4 Chemical safety measures	9
3.5 Safety measures related to the flow of sample.....	9
Section 4 Installation	11
4.1 Connecting sensor cable	11
4.2 Mechanical sensor installation.....	12
4.2.1 Installation dimensions	12
Section 5 Operation	15
5.1 Operating the sc controller	15
5.2 Sensor setup	15
5.3 Sensor data logger	15
5.4 The commands under SENSOR DIAG.....	15
5.5 The commands under SENSOR SETUP	16
5.6 Sensor calibration (conductivity)	17
5.6.1 Calibration in air (ZERO CAL).....	17
5.6.2 Calibration in air (ELECTRIC. SPAN).....	17
5.6.3 Calibration in the process (PROCESS SPAN).....	17
5.7 Adjusting the Temperature	18
5.8 Calibrating two sensors simultaneously	18
Section 6 Maintenance	19
6.1 Maintenance schedule.....	19
6.2 Cleaning the sensor.....	19
Section 7 Faults, causes, rectification	21
7.1 Error messages	21
7.2 Warnings	21
7.3 Important service data	22
Section 8 Spare parts	23
Section 9 Warranty and liability	25
Appendix A ModBUS Register Information	27

1.1 Technical data for the 3798-S sc conductivity sensor

Materials	Stainless steel metal housing, PEEK
Enclosure rating	IP 68; stainless steel metal housing
Storage temperature Sensor and controller	-20 °C ... 60 °C; 95 % relative humidity, non-condensing
Cell constant	$K = 2.35 \text{ cm}^{-1}$
Measuring range conductivity	$250 \mu\text{S}/\text{cm} \dots 1.5 \text{ S}/\text{cm}$
Temp. measuring range	-5 °C ... 50 °C
Sensor operating temperature	-20 °C ... 50 °C
Conductivity response time	< 2 s; T90
Temp. response time	< 2 min; T90
Conductivity measuring accuracy	± 3% of the measured value at 25 °C (77 °F)
Temp. measuring accuracy	± 0.2 °C
Reproducibility	< 0.2 %
Sensitivity	± 0.5 % of the end value of the measuring range
Sensor power	< 7 W
Calibration	Zero value calibration in air. Fixed value calibration with defined resistance or with standard solution
Max. immersion depth / pressure for the sensor	20 m / 2 bar
Maximum flow speed	4 m/s
Sensor interface	MODBUS
Sensor cable	10 m, hard wired, polyurethane
Sensor weight	< 1 kg
Sensor dimensions (Ø × L)	43 × 370 mm
Fastening	<ul style="list-style-type: none"> • Immersed pipe • Chain

Specifications are subject to change without notice.

2.1 General handling instructions

**Attention!**

The sensor will only work correctly when the tip of the probe is completely immersed in liquid. Ensure the tip of the probe always remains underwater even when the water level fluctuates.

2.2 Applications

CAUTION!

Potential danger with contact with chemical/biological substances. Working with chemical samples, standards and reagents can be dangerous. Make yourself familiar with the necessary safety procedures and the correct handling of the chemicals before use and read and follow all relevant safety data sheets.

The sensor facilitates the straightforward and exact determination of the conductivity of soiled to heavily soiled aqueous solutions. The system is specially designed for use in municipal and industrial waste water.

Typical applications include

- Inlet and / or outlet of a sewage treatment plant
- Surface water if within the measuring range ($> 250 \mu\text{S}/\text{cm}$).

Various different possible installations enable the system to be adapted to a very wide range of conditions.

2.3 Basic principles

The electrolytic conductivity is the ability of a liquid to conduct an electrical current (conductivity is the opposite of resistance). In metals, electrical currents are passed by the movement of electrons, in liquids by the movement of ions. The conductivity of a liquid depends on the one hand on the ionic concentration, on the other hand on the temperature of the liquid.

To obtain the real conductivity of the liquid (in S/cm), the conductivity value measured $1/R$ (in S) must be multiplied by a coefficient that depends on the geometry of the probe and that is called the "cell constant or K" ($1/\text{cm}$).

$$C = K/R \text{ (S}/\text{cm)}$$

To be able to make a comparison between the measurements made at different temperatures, the measurement must be converted to a reference temperature (as a rule 25 °C).

This temperature-dependence, expressed in [% / °C], is termed the temperature coefficient (α).

$$C_{T_{\text{ref}}} = C_T [1 + \alpha (T - T_{\text{ref}})]^{-1}$$

$C_{T_{\text{ref}}}$: conductivity adjusted to the reference temperature

C_T : conductivity measured at T

T_{ref} : reference temperature (as a rule 25 °C)

α : coefficient of the liquid temperature (%/°C)

2.4 Measuring principle

The tip of the probe comprises two coils that are completely insulated from the surrounding medium.

Primary coil (transmitter): An AC voltage is applied to the primary coil and produces an alternating electromagnetic field in the surrounding liquid. This magnetic field generates an electrical current in the liquid.

Secondary coil (receiver): The secondary coil determines the current produced by the ion movements and calculates the conductivity of the liquid from the current.

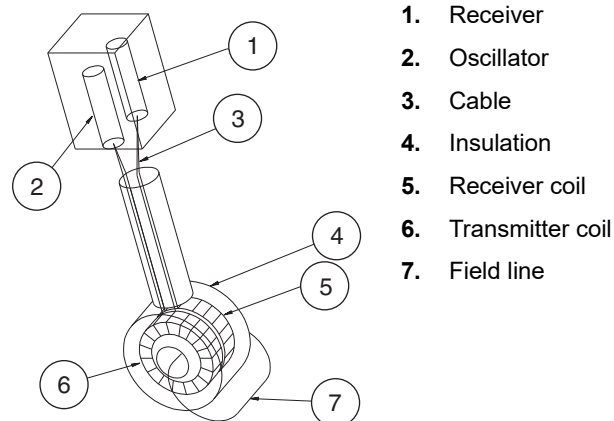

The electrical insulation between liquid and sensor (magnetic coupling) has advantages compared to the conventional method of using metal electrodes:

- no polarisation, for this reason the measuring range is larger
- high mechanical and chemical resistance
- possibility of taking measurements in soiled liquids



Prior to unpacking, commissioning or operating the instrument, read all of this manual.

Please pay particular attention to all instructions on hazards and safety. Otherwise there is a risk of serious injury to the operator or damage to the instrument, or pollution.

The sensor is only allowed to be installed and used as per the instructions in this manual.

3.1 Possible sources of hazards







During the operation or calibration of the sensor, there exist the following sources of hazards if the safety instructions are not observed:

- Potentially hazardous materials (buffer solutions, flow of sample)



In all circumstance observe the safety data sheets and the applicable health and safety instructions.

3.2 Safety symbols

All stickers and labels on the instrument are to be observed. Otherwise injuries, pollution or damage to the instrument may occur.

	This symbol, if present on the instrument, refers to information in the operating instructions on safe operation and / or instructions that provide safety information.
	This symbol, if present on a housing or a protective cover, identifies the risk of an electric shock (which may under certain circumstances be fatal). Only personnel qualified for working on hazardous voltages are allowed to open the enclosure or remove the protective cover.
	This symbol, if present on the instrument, identifies the location of a fuse or current limit.
	This symbol, if present on the instrument, identifies a part that may become hot and must not be touched without taking precautions.
	This symbol, if present on the instrument, indicates the presence of components that could be damaged by electrostatic discharge. Appropriate precautions are to be taken.
	This symbol, if present on the instrument, indicates the presence of dangerous chemical substances. Chemicals are only allowed to be handled and maintenance on devices for supplying chemicals is only allowed to be performed by personnel qualified and trained for working with chemicals.

General safety instructions

	This symbol, if present on the instrument, indicates that safety glasses must be worn.
	This symbol, if present on the instrument, identifies the location of the connection for the protective earth (ground).
	<p>As of 12 August 2005, electrical appliances marked with this symbol are no longer allowed to be disposed of in Europe in unsorted household or industrial waste. As per the applicable regulations, from this date on consumers in the EU must return old appliances to the manufacturer for disposal. This disposal is free of charge for the consumer.</p> <p>Note: You can obtain instructions on the correct disposal of all (marked and unmarked) electrical products that have been supplied or manufactured by Hach-Lange from your local Hach-Lange sales office.</p>

3.3 Electrical safety measures and fire prevention measures

The following safety instructions must be observed during the installation and repair of cables that carry electrical power:



DANGER!

Sensors and controller are designed for compliance with the U.S. and Canadian NEC as well as the European low voltage directive. No internal electrical or electronic parts are allowed to be modified in any way, as this could render the CE conformity void.

WARNING!

Only qualified experts may perform the tasks described in this section of the manual, while adhering to all locally valid safety regulations.

- Prior to maintenance or repair of the instrument, isolate it from the power supply.
- When making electrical connections, all applicable local and national regulations are to be met.
- The use of earth leakage trips is strongly recommended.
- The instrument must be correctly earthed for correct operation.

3.4 Chemical safety measures



CAUTION!

Reference and standard solutions are used for the calibration. Some of these compounds are toxic or caustic.

Potential danger with contact with chemical/biological substances. Working with chemical samples, standards and reagents can be dangerous. Make yourself familiar with the necessary safety procedures and the correct handling of the chemicals before use and read and follow all relevant safety data sheets.

Physical contact with a calibration solution and inhalation of vapours from a calibration solution are to be avoided or limited to an absolute minimum.

3.5 Safety measures related to the flow of sample

The assessment of the possible hazards from the individual sample flows is the responsibility of the user. Suitable safety measures are to be taken to avoid any unnecessary contact with a flow of sample of unknown composition in relation to the hazards due to traces of chemicals, radiation or biological effects.

4.1 Connecting sensor cable

You can connect the sensor cable to the controller very easily using the plug. Retain the protective cap for the socket in case you need to remove the sensor in the future. Connecting cables are available in the lengths 5 m, 10 m, 15 m, 20 m, 30 m and 50 m. From a length of 100 m a bus termination box must be integrated (see [Section 8 Spare parts](#)).

Fig. 1 Connection of the sensor plug to the controller

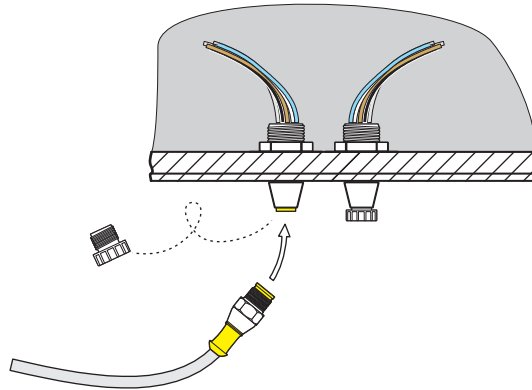
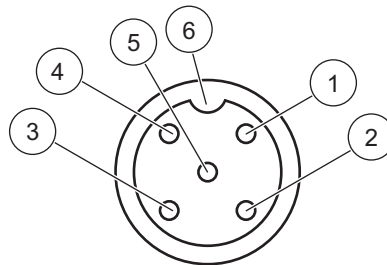

Fig. 2 Sensor connector pin assignment



Number	Description	Cable colour
1	+12 VDC	brown
2	Ground	black
3	Data (+)	blue
4	Data (-)	white
5	Screen	Screen (grey)
6	Notch	

4.2 Mechanical sensor installation



Notice!

The sensor will only work correctly when the tip of the probe is completely immersed in liquid. Ensure the tip of the probe always remains underwater even when the water level fluctuates.

CAUTION!

Potential danger with contact with chemical/biological substances. Working with chemical samples, standards and reagents can be dangerous. Make yourself familiar with the necessary safety procedures and the correct handling of the chemicals before use and read and follow all relevant safety data sheets.

Requirements

- Ensure the sensor does not collide with other instruments or objects in the tank. In this way you will avoid damaging the sensor.
- Fasten the sensor to the nearest wall with a minimum spacing of 0.5 m.

4.2.1 Installation dimensions

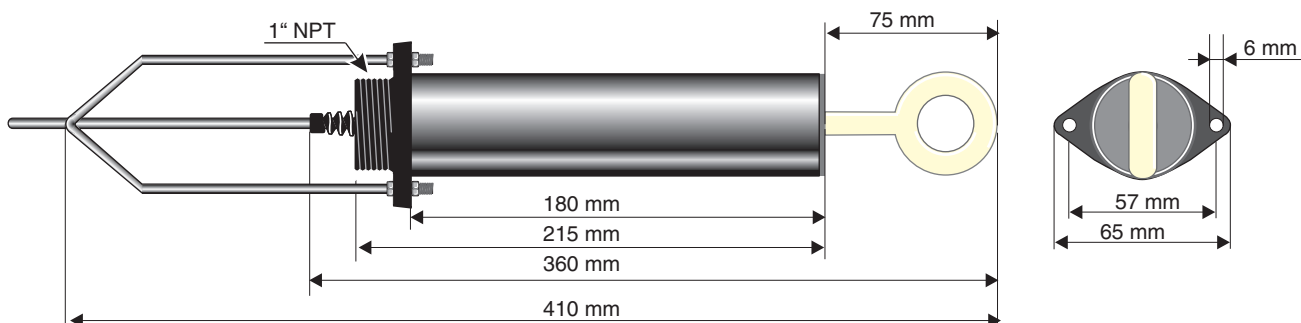
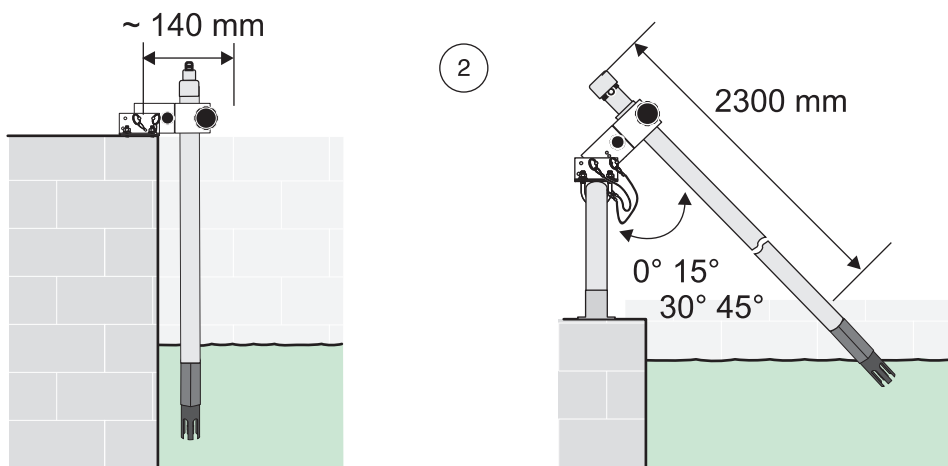
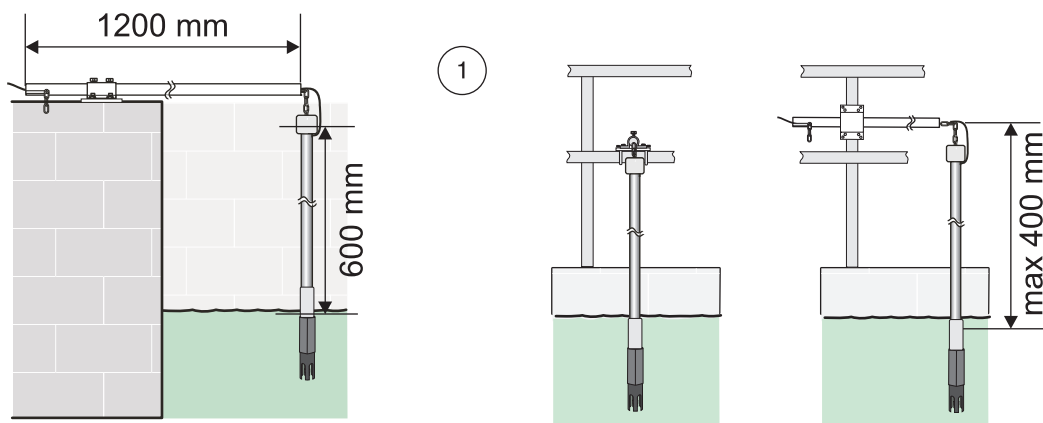

Fig. 3 Installation examples



- | | |
|---|---|
| 1. Rim mounting chain bracket, PVC or stainless steel | 2. Rim mounting immersed tube, PVC or stainless steel |
|---|---|

5.1 Operating the sc controller

The sensor can be operated with all sc controllers. Prior to using the sensor, familiarise yourself with the principle of operation of your controller. Learn how to navigate in the menus and run appropriate functions.

5.2 Sensor setup

When you connect the sensor for the first time, the serial number of the sensor is displayed as the sensor name. You can change the sensor name as follows:

1. Open the MAIN MENU.
2. Choose SENSOR SETUP and accept.
3. Choose the related sensor and accept.
4. Choose CONFIGURE and accept.
5. Choose EDIT NAME and accept.
6. Edit the name and accept to return to the SENSOR SETUP menu.

In the same way complete your system configuration using the commands as per table 5.5 "The commands under SENSOR SETUP".

5.3 Sensor data logger

A data memory and event memory per sensor are available via the sc controller. While measured data are saved in the data memory at stipulated intervals, the event memory collects numerous events such as configuration changes, alarms and warning conditions. Both the data memory and the event memory can be read out in CSV format. For information on how you can download the data, please see the controller manual.

5.4 The commands under SENSOR DIAG

SENSOR DIAG	
SELECT SENSOR (for several sensors)	
ERROR LIST	List of all errors that have occurred (see Section 7.1 "Error messages")
WARNING LIST	List of all warnings that have occurred (see Section 7.2 "Warnings")

5.5 The commands under SENSOR SETUP

SENSOR SETUP	
SELECT SENSOR (for several sensors)	
CALIBRATE	
ZERO CAL	Eliminates sensor offset See 5.6.1 "Calibration in air (ZERO CAL)".
ELECTRIC. SPAN	Calibration with a defined resistance. See 5.6.2 "Calibration in air (ELECTRIC. SPAN)".
PROCESS SPAN	Calibration with a reference solution. See 5.6.3 "Calibration in the process (PROCESS SPAN)".
PROCESS TEMP	Calibration of the temperature. See 5.7 "Adjusting the Temperature".
CAL CONFIG	
OUTPUT_MODE	Choose between: ACTIVE, output signal follows the input signal; HOLD, last measured value and output signal are held; TRANSFER, fixed value is output to the peripherals; and CHOICE
CAL REMINDER	You can set when the next calibration is to be performed. The controller then automatically indicates when the next calibration is due.
CORR FACTORS	Choose between TEMP OFFSET, GAIN CORR and GAIN VALUE,
SET CAL DEFLT	Return to the factory settings after prompt for confirmation.
CONFIGURE	
EDIT NAME	Enter a 10-character name.
PARAMETERS	Choose a parameter.
DEGREES C-F	Choose between degrees Celsius or Fahrenheit.
T-COMPENSATION	Choose between LINEAR and NONE.
T-SENSOR	
AUTOMATIC	
MANUAL	Enter a value.
FILTER	Enter a value.
LOG. DELAY	
LOG INTERVAL	Choose between the values available or DISABLED.
TEMP INTERVAL	Choose between the values available or DISABLED.
MAINS FREQ.	Enter the mains frequency.
SET DEFAULTS	Returns to the factory settings after a prompt for confirmation.
DIAG/TEST	
PROBE INFO	Provides information on driver, software and serial number
CAL DATA	Provides information on GAIN, Offset (T) and GAIN CORR.
SIGNALS	Provides information on raw data measured.
COUNTERS	Provides information on the operating time since the last calibration
TEST/MAINT	Disable OUTPUT during test or maintenance
SERVICE	Reset Service Counter

5.6 Sensor calibration (conductivity)

The sensor has been permanently calibrated and operates with great enough precision and stability that calibration is rarely necessary.

Calibrate the sensor

- as required (measured value outside the permitted tolerance, see Section 7.3 "Important service data") or
- in accordance or agreement with the authorities.

5.6.1 Calibration in air (ZERO CAL)

1. On the controller, open the menu SENSOR SETUP => CALIBRATE => ZERO CAL and accept.
2. Remove the sensor from the tank, clean and dry.
3. Accept.
4. Wait until the controller displays CAL COMPLETE.
5. Confirm that you have replaced the sensor in the sample flow and accept.

5.6.2 Calibration in air (ELECTRIC. SPAN)

1. Remove the probe from the flow of sample, clean and dry.
2. Connect a defined resistance (in range 5 Ohms - 5 kOhms) and accept to continue.
3. Enter the value for the resistance and accept.
4. Wait until the value has stabilised.
5. Accept the value.
6. Replace the probe in the flow of sample and accept.

5.6.3 Calibration in the process (PROCESS SPAN)

1. Hold the cleaned probe in the solution and accept to continue.
2. Accept when the measured value has stabilised.
3. Enter the value and accept.
4. Replace the probe in the flow of sample and accept.

Note: It is recommended to calibrate in the same conditions as later measurements (temperature and conductivity level).

5.7 Adjusting the Temperature

1. From the Main Menu, select SENSOR SETUP and confirm.
2. Highlight the appropriate sensor if more than one sensor is attached and confirm.
3. Select CALIBRATE and confirm.
4. Select PROCESS TEMP and confirm.
5. Press ENTER when Stable, TEMP: XX.X is displayed. confirm to continue.
6. Adjust the Reading XX.X °C with the keypad and confirm.
7. CAL COMPLETE, OFFSET: X.X °C, confirm to continue.
8. MOVE PROBE TO PROCESS is displayed. Confirm.

5.8 Calibrating two sensors simultaneously

1. Start by calibrating the first sensor and when you arrive at the point at which you are prompted to "PRESS ENTER WHEN STABLE".
2. Press the BACK key.
3. Select EXIT and press accept. The instrument returns to the display of the measurements. The measured value for the sensor to be calibrated starts to flash.
4. Start the calibration of the other sensor and when you again arrive at the point at which you are prompted to "PRESS ENTER WHEN STABLE".
5. Press the BACK key.
6. Select EXIT and press accept. The instrument returns to the display of the measurements. The measured values for both sensors start to flash.
7. To return to the calibration menu for the individual sensors, press the Menu key, select SENSOR SETUP and accept. Choose the required sensor and accept.

When calibration is complete, accept.

6.1 Maintenance schedule

The following table reflects experience and may, depending on the sector and application, vary significantly from actual requirements.

Maintenance task	90 days	annual
Clean sensor	x	
Check sensor for damage	x	
Calibration (if necessary)	If necessary as per agreement with the authorities	

You can set the calibration interval in the sensor setup. The controller then reminds you when calibration is due.

6.2 Cleaning the sensor

Clean the sensor with a jet of water. If there is still soiling present, use a soft, damp cloth.

7.1 Error messages

Possible sensor errors are displayed by the controller.

Table 1: Error messages

Error displayed	Cause	Rectification
*****	No communication with the controller	Check the connection to the controller Check the cable to the controller
SENSOR MISSING FFFFFFFFFFFFFF	No communication with the controller	Check the connection to the controller Check the cable to the controller
TEMP TOO LOW	Measured temperature < -5 °C	Ensure that the medium temperature is > -5 °C.
TEMP TOO HIGH	Measured temperature > +100 °C	Ensure that the medium temperature is < +100 °C.
COND TOO LOW	Conductivity < 100 $\mu\text{S}/\text{cm}$	Ensure that the conductivity is > 100 $\mu\text{S}/\text{cm}$.
COND TOO HIGH	Conductivity > 500 mS/cm	Ensure that the conductivity is < 500 mS/cm .
RES. TOO LOW	Resistance < 2 Ω	Please contact service.
RES. TOO HIGH	Resistance > 10 $\text{k}\Omega$	Please contact service.

7.2 Warnings

Possible warning messages are displayed by the controller.

Table 2: Warnings

Error displayed	Cause	Rectification
CAL TOO OLD	The last calibration was more than 180 days ago.	Calibrate the sensor
HUMIDITY BAG	The desiccant bag is more than 1000 days old.	Please contact service.

7.3 Important service data

	Data	Minimum	Maximum
CAL DATA	Electrical gain correction	95 %	105 %
	Temperature offset correction	- 5 °C	+ 5 °C
	Cell constant	2.50	2.00
Signals	Output voltage		
	Raw measured data	- 1 %	+ 1 %
Counter	Desiccant bag		
	Operating time		1000 days
MODBUS STATS	Number of communication errors	0	< 1 %
Measurement of fixed resistance 1 kΩ	Measured value	990 Ω	1010 Ω

3798-S sc, inductive conductivity sensor.....	LXV428.99.00001
User Manual	DOC023.52.03252

Accessories for the conductivity sensor

Calibration set, electrical	LZX985
Cable extension set (0.35 m).....	LZX847
Cable extension set (5 m).....	LZX848
Cable extension set (10 m).....	LZX849
Cable extension set (15 m).....	LZX850
Cable extension set (20 m).....	LZX851
Cable extension set (30 m).....	LZX852
Cable extension set (50 m).....	LZX853
Termination box	5867000
Chain bracket, V4A.....	LZX914.99.11200
Chain bracket, PVC	LZX914.99.12200
U-bolt.....	LZX959

Reference solutions

Conductivity Solution, 100 $\mu\text{S}/\text{cm}$ 1L	25M3A2000-100
Conductivity Solution, 1000 $\mu\text{S}/\text{cm}$ 1L.....	25M3A2000-1000
Conductivity Solution, 2000 $\mu\text{S}/\text{cm}$ 1L	25M3A2100-2000
Conductivity Solution, 200,000 $\mu\text{S}/\text{cm}$ 1L	25M3A2200-200K

HACH LANGE GmbH warrants that the product supplied is free of material and manufacturing defects and undertakes the obligation to repair or replace any defective parts at zero cost.

The warranty period for instruments is 24 months. If a service contract is taken out within 6 months of purchase, the warranty period is extended to 60 months.

With the exclusion of the further claims, the supplier is liable for defects including the lack of assured properties as follows: all those parts that, within the warranty period calculated from the day of the transfer of risk, can be demonstrated to have become unusable or that can only be used with significant limitations due to a situation present prior to the transfer of risk, in particular due to incorrect design, poor materials or inadequate finish will be improved or replaced, at the supplier's discretion. The identification of such defects must be notified to the supplier in writing without delay, however at the latest 7 days after the identification of the fault. If the customer fails to notify the supplier, the product is considered approved despite the defect. Further liability for any direct or indirect damages is not accepted.

If instrument-specific maintenance and servicing work defined by the supplier is to be performed within the warranty period by the customer (maintenance) or by the supplier (servicing) and these requirements are not met, claims for damages due to the failure to comply with the requirements are rendered void.

Any further claims, in particular claims for consequential damages cannot be made.

Consumables and damage caused by improper handling, poor installation or incorrect use are excluded from this clause.

HACH LANGE GmbH process instruments are of proven reliability in many applications and are therefore often used in automatic control loops to provide the most economical possible operation of the related process.

To avoid or limit consequential damage, it is therefore recommended to design the control loop such that a malfunction in an instrument results in an automatic change over to the backup control system; this is the safest operating state for the environment and the process.

Table A-3 Sensor Modbus Registers

Tag Name	Register #	Data Type	Length	R/W	Description
Measurement mS/cm	40001	Float	2	R	Conductivity in mS/cm
Measurement Ohm.cm	40003	Float	2	R	Resistivity Ohm.cm
Measurement temperature	40005	Float	2	R	Temperature
Measurement uScm	40007	Float	2	R	Conductivity in uS/cm
Measurement S/m	40009	Float	2	R	Conductivity in S/m
Measurement mS/m	40011	Float	2	R	Conductivity in mS/m
Measurement KOhm.cm	40013	Float	2	R	Resistivity KOhm.cm
Measurement Ohm.m	40015	Float	2	R	Resistivity Ohm.m
Measurement Ohm.m (2)	40017	Float	2	R	Resistivity Ohm.m2
AutoRange S/cm	40019	Integer	1	R	Auto Ranging redirection
AutoRange S/m	40020	Integer	1	R	Auto Ranging redirection of Sm
AutoRange Ohm.cm	40021	Integer	1	R	Auto Ranging redirection of Ohm.cm
AutoRange Ohm.m	40022	Integer	1	R	Auto Ranging of Ohm.m
measurement raw temperature	40023	Float	2	R	Raw Temperature
Conductivity unit	40025	Integer	1	R	Conductivity unit
Temperature unit	40026	Bit	1	R/W	Temperature unit
Output Mode	40027	Integer	1	R/W	OutputMode
Sensormame[0]	40028	Integer	1	R/W	sensorname[0]
Sensormame[1]	40029	Integer	1	R/W	sensorname[1]
Sensormame[2]	40030	Integer	1	R/W	sensorname[2]
Sensormame[3]	40031	Integer	1	R/W	sensorname[3]
Sensormame[4]	40032	Integer	1	R/W	sensorname[4]
Sensormame[5]	40033	Integer	1	R/W	sensorname[5]
Software Version (float)	40034	Float	2	R/W	Software version
Driver Version (float)	40036	Float	2	R/W	Driver version
Mains Frequency 50Hz	40038	Bit	1	R/W	Main Frequency
Function code	40039	Integer	1	R/W	Function Code
Next state	40040	Integer	1	R/W	Next Step
Password	40041	Password	1	R/W	Password
Serial number[1]	40042	Integer	1	R/W	Serial number[0]
Serial number[2]	40043	Integer	1	R/W	Serial number[1]
Serial number[3]	40044	Integer	1	R/W	Serial number[2]
Conductivity parameter	40045	Bit	1	R/W	&CMD_kunit
Temperature unit	40046	Bit	1	R/W	&CMD_tunit
Offset correction	40047	Float	2	R/W	Resistivity Offset
Electrical Calibration Resistance	40049	Float	2	R/W	Resistivity Adjust vaue
Electrical Slope	40051	Float	2	R/W	Electrical slope
Process Slope	40053	Float	2	R/W	Process slope
Main Calibration Adjust Value	40055	Float	2	R/W	Cal Conductivity Adjust Value
Second. Calibration Adjust Value	40057	Float	2	R/W	Cal Temperature Adjust Value
Temporary Meas.[0]	40059	Float	2	R/W	Temporary Measurement[0]
Temporary Meas.[1]	40061	Float	2	R/W	Temporary Measurement[1]

ModBUS Register Information

Table A-3 Sensor Modbus Registers

Constant cell	40063	Float	2	R/W	Constant cell
Temperature Compensation	40065	Bit	1	R/W	Temperature Compensation
Coefficient Compensation	40066	Float	2	R/W	Compensation Coefficient
Temperature Reference	40068	Float	2	R/W	Temperature Reference
AutomaticTemperature	40070	Bit	1	R/W	AutomaticTemperature
Manual Temperature	40071	Float	2	R/W	Manual Temperature
Temperature Offset	40073	Float	2	R/W	Temperature Offset
---	40075	Integer	1	R/W	&RS_tgMainMeas
---	40076	Integer	1	R/W	&RS_tgSecondMeas
---	40077	Integer	1	R/W	&RS_tgCalMainMeas
---	40078	Integer	1	R/W	&RS_tgCalSecondMeas
---	40079	Integer	1	R/W	&RS_tgCalMainAdjValue
---	40080	Integer	1	R/W	&RS_tgCalSecondAdjValue
---	40081	Integer	1	R/W	&RS_tgTemporary0
---	40082	Integer	1	R/W	&RS_tgTemporary1
---	40083	Integer	1	R/W	&RS_tgTempOffsetCorr
---	40084	Integer	1	R/W	&RS_tgTempRef
---	40085	Integer	1	R/W	&RS_tgTempManual
---	40086	Integer	1	R/W	Analogue Output Command
Serial Number String[0]	40087	Integer	1	R/W	&RS_sn_string[0]
Serial Number String[2]	40088	Integer	1	R/W	&RS_sn_string[2]
Serial Number String[4]	40089	Integer	1	R/W	&RS_sn_string[4]
Serial Number String[6]	40090	Integer	1	R/W	&RS_sn_string[6]
Serial Number String[8]	40091	Integer	1	R/W	&RS_sn_string[8]
Serial Number String[8]	40092	Integer	1	R/W	&RS_sn_string[10]
---	40093	Float	2	R/W	&MESS_OutputVoltage
Averaging	40095	Integer	1	R/W	Averaging
---	40096	Integer	1	R/W	&MESS_cal_code
Delay from last Calibration	40097	Integer	1	R	Delay from last Calibration
Time from Start up	40098	Integer	1	R	Time from Start up
Time of Humidity Bag	40099	Integer	1	R	Time of Humidity Bag
Conductivity Log Interval	40100	Integer	1	R	Conductivity Log Interval
Temperature Log Interval	40101	Integer	1	R	Temperature Log Interval

HACH COMPANY World Headquarters

P.O. Box 389, Loveland, CO 80539-0389 U.S.A.
Tel. (970) 669-3050
(800) 227-4224 (U.S.A. only)
Fax (970) 669-2932
orders@hach.com
www.hach.com

HACH LANGE GMBH

Willstätterstraße 11
D-40549 Düsseldorf, Germany
Tel. +49 (0) 2 11 52 88-320
Fax +49 (0) 2 11 52 88-210
info-de@hach.com
www.de.hach.com

HACH LANGE Sàrl

6, route de Compois
1222 Vézenaz
SWITZERLAND
Tel. +41 22 594 6400
Fax +41 22 594 6499

