

7000 SERIES

DISC HARROWS

OPERATION MANUAL



Read and understand the manual. This manual provides information and procedures to safely operate and maintain the Disc Harrows



Pre-Delivery Checklist

The Dealer should inform the Purchaser of this product of the Warranty terms, provisions, and procedures that are applicable. The Dealer and Purchaser should review the contents of the Operation and Parts Manual including safety equipment, safe operation and maintenance, review the Safety Signs on the implement (and tractor, if necessary), and the Purchaser's responsibility to train their operators in correct operating procedures.

- MOUNTED IMPLEMENTS: I have explained that Deflectors, Guards, or Shields must be installed and maintained in good repair, and that the operator is responsible for watching out for persons in the work area.

PRE-DELIVERY SERVICE CHECK AND ADJUST OR LUBRICATE, AS REQUIRED

See Operation and Parts Manual for Details

Inspection Performed - Warranty and Safety Procedures Explained - Installation Complete

LUBRICATION

- Grease All Zerks

IMPLEMENT

- Review Procedure to Adjust Disc Harrow
- Make Sure that All Hardware is Properly Tightened

ATTACHMENTS & INSTALLATION

- Make Sure All Bolts, Pins, and Nuts are Properly Installed and Tightened

IMPLEMENT TO TRACTOR CONNECTIONS

- Make Sure A-Frame Pivot and Links are Properly Installed

- Make Sure Lift Arms are Adjusted Equally

- Complete All Pre-Operation Checks

SAFETY ITEMS

- Make Sure Protective Shields are Properly Installed

- Review Operation and Parts Manual (Supplied)

- Make Sure Tractor PTO Shield is Installed

- Make Sure S.M.V. Sign is Installed, if Needed (Customer Supplied)

I have thoroughly instructed the purchaser on the above-described equipment. This review included the Operation and Parts Manual contents, equipment care, adjustments, safe operation, and applicable warranty policy.

Date _____

Dealer Rep. Signature _____

The above equipment and Operation and Parts Manual have been received by me, and I have been thoroughly instructed as to equipment care, adjustments, safe operation, and applicable warranty policy.

Date _____

Purchaser's Signature _____

Table of Contents

1. INTRODUCTION	6	8. SERVICE AND MAINTENANCE	26
1.1 Welcome	6	8.1 Maintenance Safety	26
1.2 Safe Operation	6	8.2 Greasing	26
1.3 Specifications	7	8.3 Disc Blade Replacement	27
1.4 Intended Usage	7	8.3.1 7100 Series Disc Blade Replacement	27
1.5 Operator Orientation	7	8.3.2 7300, 7400 Series Disc Blade	
1.6 Serial Number Location (Typical)	7	Replacement	27
1.7 Product Improvements	8	8.4 Bearing Replacement	28
1.8 Disposal of Equipment at End of Useful Life	8	8.4.1 7100 Series Bearing Cap	
1.9 Unanswered Questions	8	Replacement	28
2. SAFETY	9	8.4.2 7300, 7400 Series Bearing	
2.1 General	9	Replacement	28
2.2 Safety Alert Symbols	9	8.5 Welding Repairs	28
2.3 Safety Icon Nomenclature	10	8.6 Bolt Torque Requirements	29
2.3.1 Personal Protection/Important		8.7 Service Record	30
Information	10	9. TROUBLESHOOTING	31
2.3.2 Prohibited Actions	10	10. WARRANTY	32
2.3.3 Hazard Avoidance	10	11. PARTS INFORMATION	35
2.4 General Safety Instructions	11		
2.5 Training	12		
2.6 OSHA Training Requirements	12		
2.7 Federal Laws and Regulations	13		
2.8 Sign-Off Form	14		
2.9 Operation Safety	15		
2.10 Transporting Safety	15		
2.11 Storage Safety	15		
2.12 Maintenance Safety	15		
3. NOMENCLATURE	16		
4. ASSEMBLY	17		
4.1 Assembly Procedure	17		
5. OPERATION	18		
5.1 Operating Safety	18		
5.2 Tractor Requirements	19		
5.2.1 Tractor Safety Devices	19		
5.2.2 ROPS and Seat Belt	19		
5.2.3 3-Point Hitch	20		
5.3 Attaching to Tractor	20		
5.4 Setting the Disc Harrow	21		
5.4.1 Leveling the Frame	21		
5.4.2 Setting the Disc Angle	21		
5.4.3 Adjusting the Width	21		
5.5 Initial Setup Checklist	22		
5.6 Implement Break-In	22		
5.7 General Operating Instructions	22		
5.8 Detaching From Tractor	23		
6. TRANSPORTING	24		
6.1 Transporting Safety (Road)	24		
7. STORAGE	25		
7.1 Storage Safety	25		
7.2 Placing In Storage	25		
7.3 Removing From Storage	25		

1. INTRODUCTION

1.1 Welcome

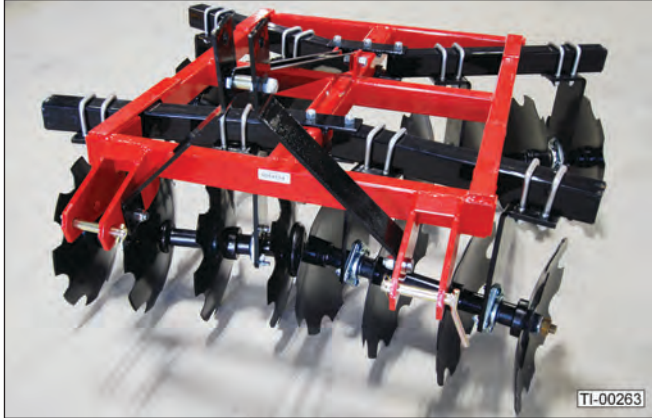

7316 Disc Harrow

Congratulations on your choice of a IronCraft disc harrow. This equipment has been designed and manufactured to meet the needs of discerning users. The IronCraft disc harrow is designed to break up the soil surface in preparation for planting.

Many features incorporated into this disc harrow are the result of suggestions made by customers like you. Read this manual carefully to learn how to operate the disc harrow safely and how to adjust it to provide maximum plowing efficiency.

By following the operating instructions, in conjunction with a good maintenance program, your IronCraft disc harrow will provide many years of trouble-free service.

This manual covers IronCraft Disc Harrow models:	
Model	Description
7112	12 blade, 16"
7116	16 blade, 16"
7316	16 blade, 18"
7320	20 blade, 18"
7324	24 blade, 18"
7416	16 blade, 20"
7420	20 blade, 20"
7424	24 blade, 20"

1.2 Safe Operation

Safe, efficient, and trouble-free operation of your disc harrow requires that you, and anyone else who will be using or maintaining the unit, read and understand the information contained within the Operation and Parts Manual.

Use this manual for reference and for new operators or owners.

WARNING



Read And Understand Manual

To prevent personal injury or even death, be sure you read and understand all of the instructions in this manual and other related OEM equipment manuals! The disc harrow, if not used and maintained properly, can be dangerous to users unfamiliar with its operation. Do not allow operating, maintaining, adjusting, or cleaning of this disc harrow until the user has read this manual and has developed a thorough understanding of the safety precautions and functions of the unit.

This disc harrow is designed for the specific purpose of breaking up the soil surface in preparation for planting. DO NOT modify or use this disc harrow for any application other than that for which it was designed.

Disc harrows maintained or operated improperly, or by untrained personnel, can be dangerous; exposing the user and/or bystanders to possible serious injury or death.

1.3 Specifications

Model	7112	7116
Horsepower Required	20-30	25-35
Working Width	48"	60"
Weight (Lbs.)	391	502
Number of Disc Blades	12	16
Disc Blade Diameter	16"	
Disc Blade Spacing	7-1/2"	
Bearings	Cast	
Hitch	CAT I	
Quick Hitch Compatible	Yes	

Model	7316	7320	7324
Horsepower Required	30-45	35-50	40-60
Working Width	60"	72"	84"
Weight (Lbs.)	650	700	750
Number of Disc Blades	16	20	24
Disc Blade Diameter	18"		
Disc Blade Spacing	7-1/2"		
Bearings	Sealed		
Hitch	CAT I		
Quick Hitch Compatible	Yes		

Model	7416	7420	7424
Horsepower Required	35-60	50-70	60-80
Working Width	72"	92"	108"
Weight (Lbs.)	872	1019	1250
Number of Disc Blades	16	20	24
Disc Blade Diameter	20"		
Disc Blade Spacing	9"		
Bearings	Sealed		
Hitch	CAT I	CAT I	CAT I & II
Quick Hitch Compatible	Yes		

Specifications subject to change without notice.

1.4 Intended Usage

Do not use this disc harrow for any other purpose than its intended use of breaking up the soil surface in preparation for planting.

1.5 Operator Orientation

The directions left, right, front, and rear, as mentioned throughout this manual, are as seen from the tractor operator's seat and facing in the direction of travel.

1.6 Serial Number Location (Typical)

The serial number decal is located on the front of the frame.



Model Number _____

Serial Number _____

1.7 Product Improvements

Because IronCraft maintains an ongoing program of product improvement, we reserve the right to make improvements in design or changes in specifications without incurring any obligation to install them on units previously sold.

1.8 Disposal of Equipment at End of Useful Life

The IronCraft disc harrow has been designed for the specific purpose of breaking up the soil surface in preparation for planting. When this unit is no longer capable of doing its designed purpose, it should be dismantled and scrapped. Do not use any materials or components from this unit for any other purpose.

1.9 Unanswered Questions

If you have any questions not answered in this manual, require additional copies, or the manual is damaged, please contact your dealer or:

IronCraft
P.O. Box 649
232 Industrial Lane
Decatur, TN 37322

Phone: (423) 334-0012
Fax: (423) 334-0023

The manual is also available for download at:
www.ironcraftco.com

1. Select "Products".
2. Select "Disc Harrows".
3. Click the "Specs., Manuals, Warranty" tab.
4. Click "Download Manual".

2. Safety

2.1 General

Safety of the operator and bystanders is one of the main concerns in designing and developing a new piece of equipment. Designers and manufacturers build in as many safety features as possible. However, every year many accidents occur which could have been avoided by a few seconds of thought and a more careful approach to handling the equipment.

Most work-related accidents are caused by failure to observe basic safety rules or precautions. An accident can often be avoided by recognizing potentially hazardous situations before an accident occurs. As you assemble, operate, or maintain the disc harrow (unit), you must be alert to potential hazards. You should also have the necessary training, skills, and tools to perform any assembly or maintenance procedures.

Improper operation and maintenance of this unit could result in a dangerous situation that could cause injury or death.

If you have any questions not answered in this manual, require additional copies, or the manual is damaged, please contact your dealer or:

IronCraft
P.O. Box 649
232 Industrial Lane
Decatur, TN 37322
Phone: (423) 405-5150
Fax: (423) 334-0023

WARNING



Do not assemble, operate, or maintain the unit until you read and understand the information contained in this manual.



Safety precautions and warnings are provided in this manual. If these hazard warnings are not heeded, bodily injury or death could occur to you or to other persons.

IronCraft cannot anticipate every possible circumstance that might involve a potential hazard. The warnings in this manual are, therefore, not all-inclusive. If a method of assembly, operation, or maintenance not specifically recommended by us is used, you must satisfy yourself that it is safe for you and for others. You should also ensure that the unit will not be damaged or be made unsafe by the methods that you choose.

The information, specifications, and illustrations in this manual are based on the information that was available at the time this material was written and can change at any time without notice.

2.2 Safety Alert Symbols



This is the safety alert symbol. It is used to alert you to potential personal injury hazards. Obey all safety messages that follow this symbol to avoid possible injury or death.

This manual contains DANGERS, SAFETY INSTRUCTIONS, CAUTIONS, IMPORTANT NOTICES, and NOTES which must be followed to prevent the possibility of improper service, damage to the equipment, personal injury, or death. The following key words call the readers' attention to potential hazards.

Hazards are identified by the "Safety Alert Symbol" and followed by a signal word such as "DANGER", "WARNING", or "CAUTION".

DANGER

Indicates an imminently hazardous situation which, if not avoided, will result in death or serious injury. This signal word is limited to the most extreme situations.

WARNING

Indicates a potentially hazardous situation which, if not avoided, could result in death or serious injury.

CAUTION

Indicates a potentially hazardous situation which, if not avoided, may result in minor or moderate injury.

NOTICE

Indicates that equipment or property damage can result if instructions are not followed.

SAFETY INSTRUCTIONS

Safety instructions (or equivalent) signs indicate specific safety-related instructions or procedures.

Note: Contains additional information important to a procedure.

2.3 Safety Icon Nomenclature

Pictorial icons signal a type of hazard and warn of personal protection issues, prohibited actions, and hazard avoidance.

2.3.1 Personal Protection/ Important Information







-  Read the manual
-  Maintenance procedure
-  Damaged hazard label
-  Eye protection
-  Fire extinguisher
-  First aid kit
-  Hand protection
-  Head protection
-  Hearing protection
-  Inspect equipment
-  OEM parts only
-  Protective shoes
-  Remove key
-  Set parking brake
-  Stop engine
-  Think safety
-  Transmission in park
-  Use proper support
-  Use proper tools

-  Use two people when lifting heavy objects
-  Visibility
-  Rollover protection
-  Wear seat belt
-  Weight rating

2.3.2 Prohibited Actions

-  Do not alter or modify
-  Use proper tools
-  Do not weld
-  No alcohol
-  No drugs
-  No smoking
-  No young children
-  No riders

2.3.3 Hazard Avoidance

-    Crush hazard
-  Crush hazard (chock wheels)
-  Crush hazard (foot)
-  Defective or broken part

-  Fall hazard
-  Fire hazard
-  Disc blade contact hazard (hand)
-  Disc blade contact hazard (foot)
-  Lifting hazard
-  Cutting hazard
-  Pinch point hazard
-  Rollover protection
-  Safety alert symbol
-  Sharp object hazard
-  Slipping injury
-  Tripping injury

2.4 General Safety Instructions

The owner/operator is responsible for the SAFE use and maintenance of the disc harrow. Make sure anyone who is operating, maintaining, or working around the disc harrow is familiar with the operating and maintenance procedures and related SAFETY information contained in this manual. This manual will take you step-by-step through your working day and alerts you to all good safety practices that should be used while using the disc harrow.

In addition to the design features of the disc harrow, including safety signs, accident prevention is dependent upon the awareness, concern, prudence, and proper training of the people involved in the operation, maintenance, and storage of the disc harrow.

In addition to this safety section, refer also to safety messages and instructions in each of the appropriate sections of the disc harrow manual.

These general safety instructions apply to the overall use and maintenance of the disc harrow.

More specific instructions on safety are found in the operation, maintenance, and storage sections of this manual. Refer to these sections before performing any of these tasks.

WARNING

Failure to comply with the following safety instructions can and will result in serious injury and possibly even death if they are not understood and followed.



Stay Clear

Clear the area of people, especially small children, before using the disc harrow. Under no circumstances should young children be allowed to work with or around the disc harrow.



Impaired User Hazard

Do not attempt to assemble, operate, or maintain this disc harrow under the influence of drugs or alcohol. Consult your doctor before using this disc harrow while taking prescription medications.



Crush Hazard

Do not allow anyone to ride on the tractor or the disc harrow. Falling or crushing hazards can result in severe injuries or death.



Falling Hazard

Do not allow riders on the hitch, tractor, or disc harrow at any time. Falling can result in severe injuries or death.

WARNING



Provide User with Literature
IronCraft disc harrow owners must provide operator instructions to anyone using the disc harrow before use, and at least annually thereafter. Refer to “2.6 OSHA Training Requirements” on page 12.



Damaged Parts Hazard
Do not use the disc harrow if any parts are damaged. If the disc harrow has a defect, immediately stop using it and remedy the problem before continuing.

CAUTION

The following safety instructions are provided to help prevent potential injury. Not following these instructions may result in minor to moderate injury.

Personal Protection Equipment

When using this disc harrow, wear appropriate personal protective equipment. This list may include, but is not limited to:



- Protective shoes with slip resistant soles
- Protective goggles, glasses, or face shield
- Protective clothing and gloves
- Safety vest (when operating near roads)
- Hearing protection



Hearing Loss

Prolonged Exposure To Loud Noise May Cause Permanent Hearing Loss!

Working environments with noise-producing equipment can cause partial to permanent hearing loss. We recommend using hearing protection any time noise levels exceed 80 decibels (dB). Noise levels over 85 dB, on a long-term basis, can cause severe hearing loss. Noise levels over 90 dB over a period of time can cause permanent and even total hearing loss.

Hearing loss from loud noise is cumulative over a lifetime without hope of natural recovery.



Crush Hazard

The tractor should be equipped with a Roll Over Protective Structure (ROPS) and a seat belt. A crushing hazard can occur if the driver is ejected from the seat while the tractor is in motion. Fasten the seat belt whenever the tractor is moving.

SAFETY INSTRUCTIONS

The following safety instructions are provided to help prevent injury or limit equipment damage.



First Aid Kit

Have a first aid kit available for use should the need arise and know how to use it.



Fire Extinguisher

Have a fire extinguisher available for use should the need arise and know how to use it.



Think SAFETY!

Work SAFELY!

2.5 Training

Anyone who will be using and/or maintaining the disc harrow must read, clearly understand, and follow ALL safety, operation, and maintenance information presented in this manual and other related OEM manuals.

If you do not understand any information in this manual, see your dealer or contact IronCraft before proceeding.

Do not use or allow anyone else to use this disc harrow until all information has been reviewed. Annually review this manual before the season start-up.

Make periodic reviews of SAFETY and OPERATION of the disc harrow a standard practice. An untrained operator is not qualified to use this disc harrow.

2.6 OSHA Training Requirements

The following training requirements have been taken from Title 29, Code of Federal Regulations Part 1928.57 (a) (6). www.osha.gov.

Operator instructions. At the time of initial assignment and at least annually thereafter, the employer shall instruct every employee who operates an agricultural tractor and implements in the safe operating practices and servicing of equipment with which they are or will be involved, and of any other practices dictated by the work environment.

2.7 Federal Laws and Regulations

IMPORTANT FEDERAL LAWS AND REGULATIONS CONCERNING EMPLOYERS, EMPLOYEES AND OPERATORS

This section is intended to explain in broad terms the concept and effect of the following federal laws and regulations. It is not intended as a legal interpretation of the laws and should not be considered as such.

U.S. PUBLIC LAW 91-596 (The Williams-Steiger Occupational Safety and Health Act of 1970) OSHA

This Act Seeks:

" ... to assure so far as possible every working man and woman in the nation safe and healthful working conditions and to preserve our human resources ... "

DUTIES

Sec. 5(a) Each Employer -

- (1) shall furnish to each of its employees employment and a place of employment which are free from recognized hazards that are causing or are likely to cause death or serious physical harm to its employees.
- (2) shall comply with occupational safety and health standards promulgated under this Act.
 - (b) Each employee shall comply with occupational safety and health standards and all rules, regulations, and orders issued pursuant to this Act which are applicable to his or her own actions and conduct.

OSHA Regulations

Current OSHA regulations state in part: "At the time of initial assignment and at least annually thereafter, the employer shall instruct every employee in the safe operation and servicing of all equipment with which the employee is, or will be involved." These will include (but are not limited to) instructions to:

Keep all guards in place when the machine is in operation;

Permit no riders on equipment;

Stop engine, disconnect the power source, and wait for all machine movement to stop before servicing, adjusting, cleaning, or unclogging the equipment, except where the machine must be running to be properly serviced or maintained, in which case the employer shall instruct employees as to all steps and procedures which are necessary to safely service or maintain equipment.

Make sure no one is within 300 feet of machinery before starting the engine, engaging power, or operating the machine.

EMPLOYEE TRACTOR OPERATING INSTRUCTIONS:

1. Securely fasten your seat belt if the tractor has a ROPS.
2. Where possible, avoid operating the tractor near ditches, embankments, and holes.
3. Reduce speed when turning, crossing slopes, and on rough, slick, or muddy surfaces.
4. Stay off slopes too steep for safe operation.
5. Watch where you are going, especially at row ends, on roads, and around trees.
6. Do not permit others to ride.
7. Operate the tractor smoothly - no jerky turns, starts, or stops.
8. Hitch only to the drawbar and hitch points recommended by tractor manufacturers.
9. When tractor is stopped, set brakes securely and use park lock if available.

Child Labor Under 16 Years Old

Some regulations specify that no one under the age of 16 may operate power machinery. It is your responsibility to know what these regulations are in your own area or situation. (Refer to U.S. Dept. of Labor, Employment Standard Administration, Wage & Home Division, Child Labor Bulletin #102).

2.8 Sign-Off Form

IronCraft follows the general Safety Standards specified by the Farm Equipment Manufacturers Association (FEMA), and the American National Standards Institute (ANSI). Anyone who will be using and/or maintaining the disc harrow must read and clearly understand ALL safety, operation and maintenance information presented in this manual.

Do not use or allow anyone else to use this disc harrow until all information has been reviewed. Annually review this manual before the season start-up. Make periodic reviews of SAFETY and OPERATION of the disc harrow a standard practice. An untrained operator is not qualified to use this disc harrow.

This sign-off sheet is provided for your records to show that all personnel who will be working with the equipment have read and understand the information in this Operation and Parts Manual and have been instructed in the operation of the equipment.

Sign-Off Form		
Date	User's Signature	Owner's Signature

2.9 Operation Safety

Refer to “5.1 Operating Safety” on page 18 for safety recommendations related to using the disc harrow. All applicable safety recommendations in other sections should also be followed.

2.10 Transporting Safety

Refer to “6.1 Transporting Safety (Road)” on page 24 for safety recommendations related to transporting the disc harrow. All applicable safety recommendations in other sections should also be followed.

2.11 Storage Safety

Refer to “7.1 Storage Safety” on page 25 for safety recommendations related to storing the disc harrow. All applicable safety recommendations in other sections should also be followed.

2.12 Maintenance Safety

Refer to “8.1 Maintenance Safety” on page 26 for safety recommendations related to maintaining the disc harrow. All applicable safety recommendations in other sections should also be followed.

3. Nomenclature

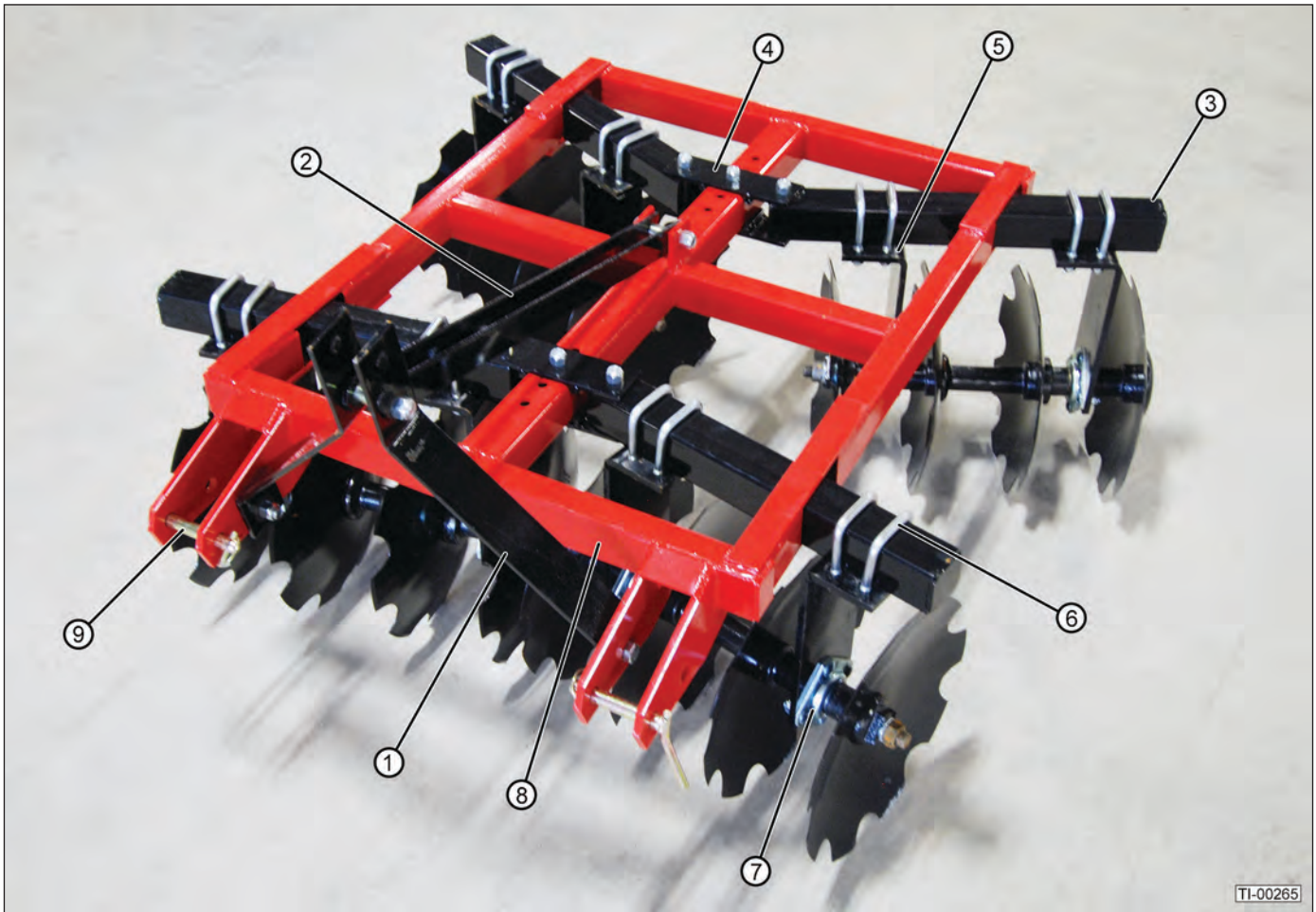

Item	Description
1	A-Frame
2	Back Brace
3	Disc Gang Tube
4	Pivot Plate
5	Bearing Hanger
6	Hanger U-Bolt
7	Bearing
8	Frame
9	CAT I 3-point Hitch Pin and Retainer Clip

4. Assembly

4.1 Assembly Procedure

The disc harrow ships with the A-frame folded down for shipping purposes. It must be erected before use.

1. Cut the wires holding the back brace and A-frame to the disc harrow frame. Remove the hitch pins from the frame.



2. Using a 1-1/8" wrench, loosen rear back brace bolt (1) and lower A-frame bolts (2). Remove front bolt (3) and spacer (4) from the back brace.

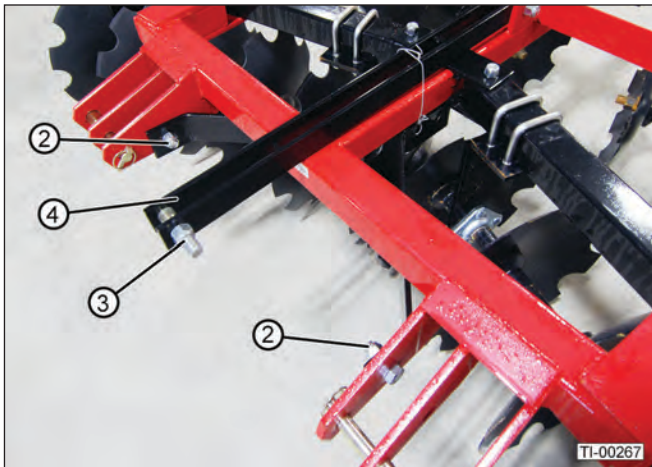

3. Rotate the A-frame halves to an upright position. Assemble the back brace, bolt, and spacer on the inside of the A-frame. Make sure to install the bolt in the lower A-frame holes.

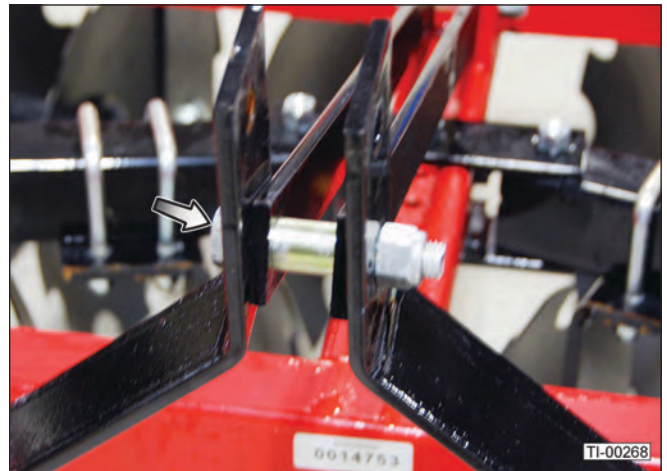

4. Tighten the A-frame and back brace bolts securely. Reinstall the hitch pins.



5. Operation

5.1 Operating Safety

Refer to “2.4 General Safety Instructions” on page 11 for general user safety training requirements.

WARNING



Roll Away Hazard

Before leaving the tractor seat, make sure the engine is stopped, the transmission is placed in park, the key is removed, and the parking brake is set.



The weight of the tractor, plus the disc harrow if it rolls onto a person, can cause serious crushing injury or death.



Crush Hazard

The tractor should be equipped with a Roll Over Protective Structure (ROPS) and a seat belt. A crushing hazard can occur if the driver is ejected from the seat while the tractor is in motion. Fasten the seat belt whenever the tractor is moving.



Stay Clear

Clear the work area of all unnecessary people and obstructions to prevent personal injury.



Disc Blade Contact Hazard (hand)

To avoid serious injury or death, keep away from ground-engaging components. Do not put hands under disc harrow.



Disc Blade Contact Hazard (foot)

To avoid serious injury or death, keep away from ground-engaging components. Do not put feet under disc harrow.

SAFETY INSTRUCTIONS

The following safety instructions are provided to help prevent injury or limit equipment damage.



Train Unfamiliar Users

It is the disc harrow owner's responsibility to make sure any person using the disc harrow, especially if it is loaned or rented, has been thoroughly trained on its proper and safe use.

Be certain only physically-able persons will use the disc harrow.

Untrained users expose themselves and bystanders to possible serious injury or death.

If the elderly are assisting with the work, their physical limitations need to be recognized and accommodated.

Never allow children to operate equipment.

Do not operate the disc harrow, or drive the tractor into material that is burning, or areas that recently burnt and may contain hot spots. Tire damage can occur when driving over hot material. Oil and grease on the tractor and disc harrow could ignite, resulting in equipment destruction.

5.2 Tractor Requirements



⚠️ WARNING



Tractor Owner/Operator Manual
Always refer to the tractor Operator's Manual to ensure compatibility and maximum safety.

The tractor used to operate the disc harrow must have the power capacity to lift and pull the disc harrow at a ground speed between 2 and 5 MPH.

Use the chart to select the tractor horsepower appropriate for your disc harrow. Do not use a tractor of more than the recommended HP to prevent overloading frame components.

Model	Recommended HP
7112	20-30
7116	25-40
7316	30-45
7320	35-45
7324	40-50
7416	35-60
7420	50-70
7424	60-80

The tractor must be matched to the weight of the disc harrow. A minimum of 20% of the combined tractor and equipment weight should be on the front wheels. This will ensure adequate stability during transport and operation.

Always review the “controls” section of the tractor Operator's Manual to be familiar with the location, settings, and function of the tractor controls. Be familiar with all controls before using this equipment.

5.2.1 Tractor Safety Devices

If transporting or operating the tractor and implement near a public roadway, the tractor must be equipped with proper warning lighting and a Slow Moving Vehicle (SMV) emblem, which are clearly visible from the rear of the unit. Lights and a SMV emblem must be attached directly to the implement if the visibility of the tractor warning signals are obscured.

Never operate the tractor PTO with the PTO master shield missing or in the raised position.

5.2.2 ROPS and Seat Belt

⚠️ WARNING



Rollover Hazard

To avoid serious injury or death from falling off tractor, equipment rollover, rollover, or crushing:

- 1) Use ROPS equipped tractor.
- 2) Keep ROPS locked in the UP position.
- 3) Only operate the equipment when seated in the tractor seat.
- 4) Always fasten seat belt when operating the tractor and disc harrow.

The tractor must be equipped with a Roll Over Protective Structure (ROPS) (tractor cab or roll-bar) and seat belt to protect the operator from falling off the tractor, especially during a roll-over where the driver could be crushed and killed. Only operate the tractor with the ROPS in the raised position and seat belt fastened.

5.2.3 3-Point Hitch

These disc harrows are designed to be mounted on a tractor CAT I 3-Point or Quick Hitch. The 7400 models are equipped with stepped pins to accommodate CAT I or CAT II hitches.

Refer to the tractor Operator's Manual for the category of the tractor being used. If the hitch does not conform to ASABE CAT I dimensions, the disc harrow may not fit or raise properly. Consult an authorized dealer for possible modification procedures to mount non-conforming hitches. Depending on the hitch category, certain size pins are used to attach the implement to the tractor. CAT I hitches require 7/8" lower and 3/4" upper diameter hitch pins.

Always set the 3-point hitch in the "float" mode to allow the disc harrow to follow the contour of the ground.

Many newer tractors are equipped with "load sensing" hydraulics. It is the responsibility of the operator to set the tractor hydraulic system to provide "float" on the 3-point hitch. Refer to the tractor manual for details.

Install the lift arm stabilizer or shorten the stop chains to place the arms into the non-sway configuration. Refer to the tractor manual for details.

Always install weights on the front of the tractor to provide extra stability and traction. This is particularly important if your tractor is equipped with a front wheel assist option.

5.3 Attaching to Tractor

Use caution when connecting the disc harrow to the tractor. The disc harrow should be securely resting at ground level or setting on blocks. Keep hands and feet from under the plow and clear of pinch points between the tractor hitch arms and disc harrow hitch pins.

WARNING



Crush Hazard

Crush hazard between hitch and implement. Do not allow anyone to stand between the hitch and implement during hook-up operations. Never operate the hydraulic 3-point lift controls while someone is directly behind the tractor.

1. Shorten or remove the tractor drawbar to avoid interference when raising and lowering the disc harrow.
2. Board the tractor and start the engine. Position the tractor with the 3-point lift arms positioned at the same height and to the outside of the disc harrow hitch pins.
Note: Set the 3-point lift control to "Position Control" so that the lift arms maintain a constant height when attaching the disc harrow. See the tractor Operator's Manual for correct settings when attaching 3-point equipment.
3. Turn off the tractor engine and dismount.
4. One lift arm at a time, insert hitch pin through the lift arm holes and install retaining pin.
5. Walk around to the opposite side and repeat the procedure for the remaining lift arm and hitch pin.
6. Extend or retract the 3-point top link to align its end hole with the hole of the disc harrow's top link. Insert the top link hitch pin and insert the retaining pin into the hitch pin.
7. Adjust any lower link check chains, guide blocks, or sway blocks to prevent the disc harrow from swaying side-to-side and possible contact with the tractor rear tires.

5.4 Setting the Disc Harrow

Properly setting the disc harrow is essential for efficient and safe operation. A properly adjusted disc harrow will break up the soil more evenly, require minimal tractor work, and follow the contour of uneven terrain.

5.4.1 Leveling the Frame

1. Use the screw jack on the right lift arm to level the frame from side-to-side. The frame should be level when the disc is at working depth.
2. Use the turnbuckle on the top link to level the frame from front to back. The frame should be parallel to the ground when the disc is at working depth.
3. Place the 3-point hitch in "float" operating mode to allow the machine and the hitch to move up and down, as required to follow ground contours.

5.4.2 Setting the Disc Angle

The more aggressive the angle of the gangs, the more aggressive the cutting action in the soil profile will be. The more aggressive the cutting action is, the more horsepower will be required to pull the unit.

1. Using the tractor hydraulics, raise the disc harrow off the ground and lower it onto blocks. Place the transmission in park or neutral and apply the parking brake. Shut down the engine and remove the key before exiting the tractor.
2. Remove the center adjustment bolt.



3. Move the carriage to the desired position.
4. Install the adjustment bolt in the desired hole location and tighten securely.

NOTE: For a better ground finish, set the rear gangs at a less aggressive angle than the front gangs.

5.4.3 Adjusting the Width

Width adjustments can be made by loosening the U-bolts and sliding the disc gangs in or out to the desired position.

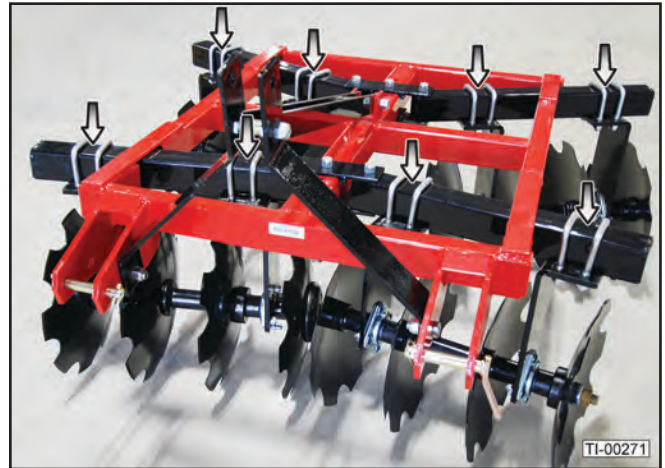





Note: The rear discs should be centered between the front discs for best performance.

5.5 Initial Setup Checklist

Efficient and safe operation of the disc harrow requires that every user read and understand the operational instructions and all related safety instructions outlined in this manual.

This checklist is provided for the user/owner. It is important for both personal safety and to maintain the mechanical condition of the disc harrow that this checklist is followed.

Initial Setup Checklist (prior to using for the first time)		
☐	Location	Task
		Make sure the disc harrow is properly mounted to the 3-point hitch. Refer to "5.3 Attaching to Tractor" on page 20.
		Make sure all hardware is properly installed and tightened. Refer to "8.6 Bolt Torque Requirements" on page 29.
		Check the condition of the disc blades. Refer to "8.3 Disc Blade Replacement" on page 27.
		Check the disc harrow setup. Adjust if needed. Refer to "5.4 Setting the Disc Harrow" on page 21.
		For 7100 series disc harrows only, grease the zerks on the bearing caps. Refer to "8.2 Greasing" on page 26.

5.6 Implement Break-In

Although there are no operational restrictions on the disc harrow when used for the first time, it is recommended that the following mechanical items be checked:

1. After 1/2 hour of operation:
 - a. Check all fasteners and tighten if necessary.
 - b. Make sure that the ground-contacting components are in good condition.
 - c. Lubricate the axle bearing caps. (7100 Series only).
2. After 10 hours of operation:
 - a. Go to the normal servicing and maintenance schedule, as defined in the Maintenance Section.

5.7 General Operating Instructions

Before putting the disc harrow into service, thoroughly review the Operation and Parts Manual. Inspect the overall condition of the disc harrow for potential problems or damage. Do not use the disc harrow if it needs repairs of any type. Attach the disc harrow to the tractor, and transport it to the work site.

Use only an appropriately-sized tractor to pull the disc harrow. Operate only in conditions where you have clear visibility in daylight or with adequate artificial lighting. Never operate the disc harrow in darkness or foggy conditions where you cannot clearly see at least 300 feet in front and to the sides of the tractor and disc harrow.

Clear the area of bystanders, especially small children. Make sure that you can clearly see and identify passersby, steep slopes, ditches, drop-offs, power lines, debris, and foreign objects. If you are unable to clearly see these type of items, discontinue operating the disc harrow. Thoroughly inspect the work area for stones, branches, debris, buried utility cables, pipelines, sprinkler heads, and any other hard objects that may be struck. Never operate the disc harrow in an area that you have not inspected and removed debris or foreign material. Contact local utilities before operating. Know the location of all underground cables, pipelines, and other hazards in the area. Mark the location of objects that cannot be removed. Watch for trees, low hanging limbs, power lines, and other overhead obstacles while operating. Use care to avoid hitting these items.

Do not attempt to work wet or sticky soil. All areas should be well drained and capable of being walked on without having the soil stick to your shoes. Always cross steep ditches and banks on the diagonal, never straight across. Damage to the disc and/or tractor may occur while crossing straight across.

Discing action will begin as soon as the disc touches the ground and the tractor begins to move forward. Forward travel speed will be determined by soil conditions and available tractor horsepower.

Never try to disc in reverse. The disc harrow is designed for working while traveling forward only. Damage to the unit may occur if it is operated while backing up. The recommended procedure for working corners or other tight places is to lift the unit, back into the corner or other tight area, lower the unit, and proceed forward.

When you reach the end of a pass, pick the unit up before turning. Trying to turn with the disc in the ground will cause side loads on the disc and may cause damage.

Making disc gang adjustments is relatively easy by raising the disc off of the ground, placing safety blocks under the frame, making the required adjustment, removing the safety blocks and resuming operation. Refer to "5.4.2 Setting the Disc Angle" on page 21 for detailed instructions.

Ground conditions and the finish required will determine the angles of the front and rear disc gangs. The more aggressive the angle of the gangs, the more aggressive the cutting action in the soil profile will be, and the more horsepower will be required to pull the unit.

Achieving the desired results may require some experimentation. The best ground finish will usually be achieved when the rear gang is set at a slightly less aggressive angle than the front gang. If the soil is building up on or sticking to the discs, the soil is too wet and operations should be discontinued until the ground is drier and more workable.

5.8 Detaching From Tractor

1. Move the disc harrow to a level storage location and lower it to the ground or onto blocks. Park the tractor, place the transmission in park or neutral, and apply the parking brake. Shut down the engine, and remove the key before exiting the tractor.
2. Make sure the disc harrow is resting securely on the ground or blocks before attempting to disconnect it from the tractor.

WARNING



Crush Hazard

Keep feet and hands from under the disc harrow and clear of any pinch points caused by the tractor hitch arms and disc harrow hitch pins. Never operate the hydraulic 3-point lift controls while someone is directly behind the tractor.

3. Extend the tractor 3-point hitch top link to remove tension on the top link hitch pin. When the pin is loose and easy to rotate, remove the pin from the disc harrow. Disconnect the lift arms.

6. Transporting

6.1 Transporting Safety (Road)

Refer to “2.4 General Safety Instructions” on page 11 for general transporting safety requirements.

WARNING

The following safety instructions are provided to help prevent serious injury and possibly even death.



Operating the Tractor

Before attaching the disc harrow to the tractor, be familiar with its controls and how to stop it quickly in the event of an emergency. Read and understand this manual and the one provided with your tractor before transporting the disc harrow.

SAFETY INSTRUCTIONS

The following safety instructions are provided to help prevent injury or limit equipment damage.



Drive Safely

Be a safe and courteous driver. Anticipate what other drivers will do and drive accordingly.



Allow Extra Distance

Apply brakes early. Leave extra distance between your vehicle and the one(s) ahead to provide adequate stopping space. Extra distance will be required to stop the vehicle.



Clear Vision

Remove all objects from the area that would prevent clear vision of the complete work area or would present an obstacle when moving the disc harrow.



Hitch Attachment

Be sure the disc harrow is securely attached to the tractor and in good operating condition before using.



Working Taillights

Make sure lights on the tractor are working properly.



Additional Lighting

For disc harrows without lights, install additional lights on the rear of the tractor to safeguard against rear-end collisions. Daybreak and dusk are particularly dangerous and rear pilot vehicles are recommended. Disc harrows should be transported on public roads only during daylight hours.

SAFETY INSTRUCTIONS



Hazard Flashers

Use hazard flashers on the tractor when transporting unless prohibited by law.



Right-of-Way

When travelling below the posted speed limit, keep to the right and yield the right-of-way to allow faster traffic to pass.



Tractor Owner/Operator Manual

Always refer to the tractor Operator’s Manual to determine its compatibility and maximum safety.



Maximum Transporting Speed

Do not exceed 20 MPH when transporting the disc harrow. Slow down for corners and rough terrain.



Visibility

Clean reflectors, SMV or SIS sign, and lights before transporting. Make sure all the lights and reflectors required by highway and transport authorities are in place and can be seen clearly by all overtaking and oncoming traffic.



Regulations

Make sure all local, state, and federal regulations, regarding the transport of equipment on public roads and highways, are met. Check with the local authorities regarding transporting the disc harrow on public roads. Obey all applicable laws and regulations.

7. Storage

7.1 Storage Safety

At the end of the season, the disc harrow should be thoroughly inspected and prepared for storage. Repair or replace any worn or damaged components to prevent any unnecessary downtime at the beginning of the next season.

CAUTION



Personal Injury Hazard

Store the disc harrow in an area away from human activity. To prevent the possibility of serious injury, do not permit children to play on or around the stored disc harrow.

NOTICE

To prevent damage to the disc harrow, store it in a dry, level area.

7.2 Placing In Storage

1. Remove all entangled vegetation.
2. Thoroughly wash the disc harrow with a pressure washer or water hose to remove all dirt, mud, or debris.
3. Select an area that is dry, level, and free of debris (inside a building is ideal). Move the disc harrow to its storage area.
4. Lower the disc harrow onto blocks.
5. Disconnect the disc harrow from the 3-point hitch and drive the tractor away from the disc harrow. Refer to “5.8 Detaching From Tractor” on page 23. Do not leave the tractor attached to the disc harrow.
6. Lubricate all grease points. Make sure all grease cavities have been filled with grease to remove any water residue from washing.
7. Touch up all paint nicks and scratches to prevent rusting.

7.3 Removing From Storage

When removing the disc harrow from storage, follow this procedure:

1. Before placing the disc harrow back into service, replace any worn or defective parts and perform the Pre-Operation Checklist.
2. Attach the disc harrow to the tractor 3-point hitch. Refer to “5.3 Attaching to Tractor” on page 20.
3. Raise the disc harrow up off the blocks.

8. Service and Maintenance

8.1 Maintenance Safety

WARNING

The following safety instructions are provided to help prevent serious injury and possibly even death.



Damaged Parts Hazard

Do not use the disc harrow if any parts are damaged. If the disc harrow is believed to have a defect which could cause it to work improperly, immediately stop using it and remedy the problem before continuing.



No Unauthorized Modifications

Do not modify the disc harrow or safety devices. Do not weld on the unit. Unauthorized modifications may impair its function and safety and will void the warranty.

If the disc harrow has been altered in any way from the original design, the manufacturer does not accept any liability for injury or warranty.



Proper Support

Use certified safety stands rated to support the load when performing repairs, service, or maintenance.

Make sure the jack stands are stable and the disc harrow is approximately level. Test the stability of the disc harrow before performing repairs, service, or maintenance.

If the disc harrow is attached to the tractor, set the brakes, remove the key, chock the tractor wheels, and block the disc harrow before performing repairs, service, or maintenance.

Tighten the lower 3-point arm anti-sway mechanism to prevent side-to-side movement.



Good Working Condition

Keep all parts in good condition and properly installed. Fix damage immediately. Replace worn or broken parts.



Replacement Parts

If replacement parts are necessary, genuine factory replacement parts must be used to restore the unit to its original specifications. IronCraft will not accept responsibility for damages as a result of the use of unapproved parts.

SAFETY INSTRUCTIONS

The following safety instructions are provided to help prevent injury or limit equipment damage.



Clean Work Area

Do not leave tools lying around the work area. Follow good shop practices. Keep service area clean and dry. Be sure electrical outlets and tools are properly grounded. Use adequate light.



Use the Right Tools

Use the correct tools, jacks, hoists, or other tools that have the capacity for the job.

8.2 Greasing

Grease the zerks on the axle bearing caps of 7100 Series disc harrows before each use. Use an SAE multipurpose lithium base grease.

1. Always use a handheld grease gun for all greasing.
2. Wipe grease zerks with a clean cloth before greasing to avoid injecting dirt and grit.
3. Apply grease until new grease can be seen coming out of the joint.
4. Do not let excess grease collect on or around parts, particularly when operating in sandy areas.
5. Replace any broken grease zerk immediately.
6. If any grease zerk will not take grease, remove and clean it thoroughly. Also clean the lubricant passageway. Replace the zerk if necessary.

8.3 Disc Blade Replacement

Disc blades are subject to abrasion and wear. Worn disc blades will require replacement.

8.3.1 7100 Series Disc Blade Replacement

1. Remove carriage bolts (1) and locknuts (2) from both bearing hangers (3) that secure the disc harrow gang to the frame.

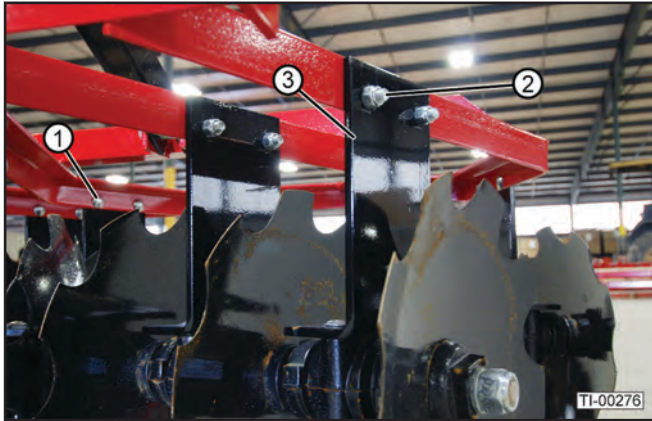

2. Remove lock nut (4), end cap (5), and lock washer (6) on the end of the disc gang.

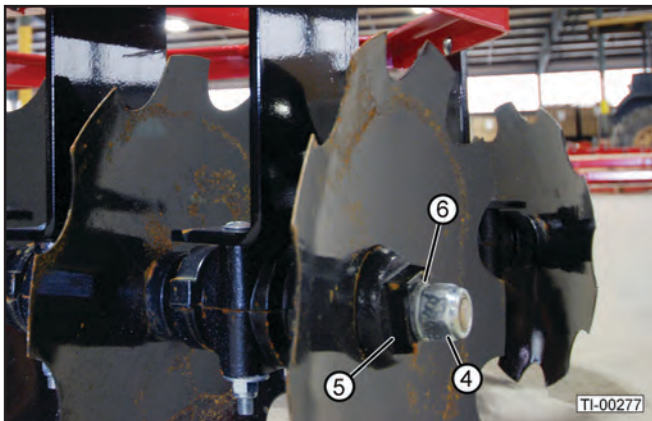

3. Slide discs, spacers, and bearing mounts off the axle as needed to replace the desired disc.

NOTE: Maintain proper order of discs, spacers, and bearing mounts for reassembly.

4. Install new disc in place of worn/damaged disc.
5. Reassemble gang with new disc. Assemble in reverse order of disassembly.
6. Secure gang assembly to the frame using bolts (1) and locknuts (2) previously removed.

8.3.2 7300, 7400 Series Disc Blade Replacement

1. Detach the disc gang from both bearing hangers (10) by removing three carriage bolts (7), and lock nuts (8).

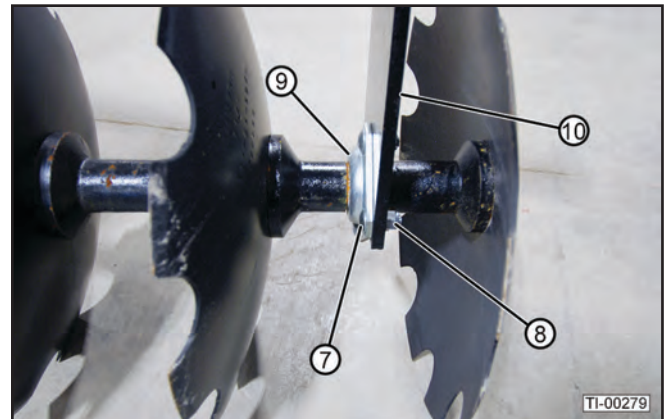

2. Remove end cap (4), lock nut (5), and lock washer (6) on the end of the disc gang.

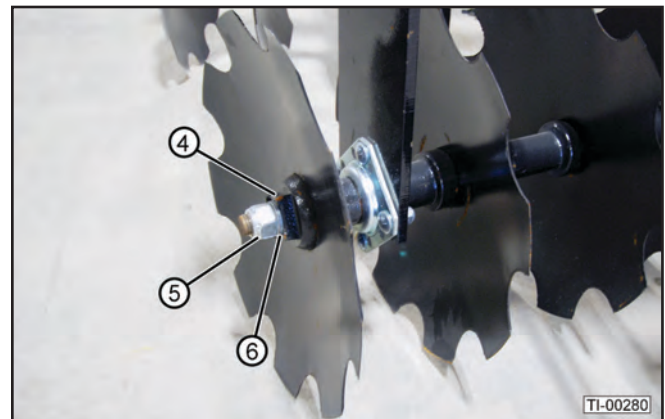

3. Slide discs, spacers, and bearings off the axle as needed to replace the desired disc.

NOTE: Maintain proper order and orientation of discs, spacers, and bearings for reassembly.

4. Install new disc in place of worn/damaged disc.
5. Reassemble discs, spacers, and bearings previously removed. Assemble in reverse order of disassembly.
6. Attach the disc gang assembly to the bearing hangers using carriage bolts (7), and lock nuts (8) previously removed.

8.4 Bearing Replacement

8.4.1 7100 Series Bearing Cap Replacement

1. Remove bearing mount following Steps 1-3 in “8.3.1 7100 Series Disc Blade Replacement” on page 27.
2. Remove carriage bolts (7), lock nuts (8), and flat washers (9) from bearing hanger (10).

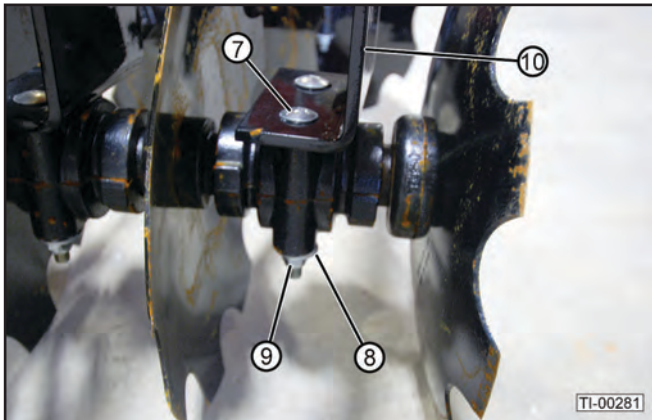

3. Separate and remove the bearing cap halves.
 4. Install the new bearing cap halves using the carriage bolts, washers, and locknuts previously removed.
 5. Reassemble gang with new bearing. Assemble in reverse order of disassembly.
- NOTE:** Maintain proper order of discs, spacers, and bearing mounts for reassembly.
6. Secure gang assembly to the frame using carriage bolts (1) and locknuts (2) previously removed.
 7. Grease the zerks on the new axle bearing caps. This would be a good time to grease the remaining axle bearing caps as well.

8.4.2 7300, 7400 Series Bearing Replacement

1. Remove and disassemble the disc gang following Steps 1-3 in “8.3.2 7300, 7400 Series Disc Blade Replacement” on page 27.
2. Reassemble the disc gang with new bearing (9). Assemble in reverse order of disassembly.

NOTE: Maintain proper order and orientation of discs, spacers, and bearings for reassembly.

3. Secure the disc gang assembly to the bearing hangers (10), using carriage bolts (7), and lock nuts (8) previously removed.

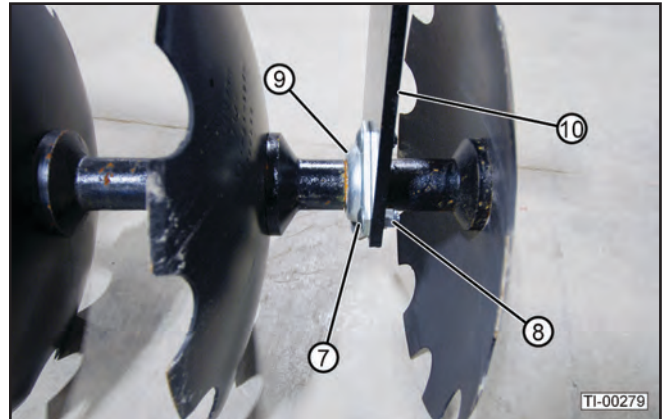

8.5 Welding Repairs



Before performing any type of welding repair to the disc harrow, contact IronCraft for approval. Repair welding must be done with care and with procedures that may be beyond the capabilities of the ordinary welder.

WARNING



Personal Injury Hazard
Repairs or modifications to the disc harrow can result in serious injury or death should these repairs fail.

NOTICE

Anyone performing a welding repair should be certified in accordance to the American Welding Society (AWS) standards.

8.6 Bolt Torque Requirements

It is extremely important to apply and maintain proper torque on all bolts. Use a torque wrench to assure the proper amount of torque is being applied to the fastener.

Start all bolts or nuts by hand to prevent cross threading.

Torque figures indicated in the chart are used for non-greased or non-oiled threads and heads unless otherwise specified. Therefore, do not grease or oil bolts or cap screws unless otherwise specified in this manual. When using locking elements, increase torque values by 5%.



The chart below gives correct torque values for various bolts and cap screws. Tighten all bolts to the torque specified in the chart unless otherwise noted. Check tightness of bolts periodically, using the bolt torque chart as a guide. Always replace hardware with the same Grade bolt.

⚠ WARNING

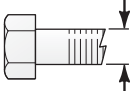
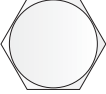

EQUIPMENT FAILURE

The torque value for bolts and cap screws are identified by their head markings. Replacing higher "Grade" bolts (Grade 5) with lower Grade bolts will lead to equipment failure and can result in injury or death. Always use replacement bolts with the same Grade markings as the removed bolt.

Bolt Diameter 	English Bolt Torque Specifications					
	Grade 2 		Grade 5 		Grade 8 	
	N·m	ft.lbs.	N·m	ft.lbs.	N·m	ft.lbs.
1/4"	8	6	12	9	17	12
5/16"	13	10	25	19	36	27
3/8"	27	20	45	33	63	45
7/16"	41	30	72	53	100	75
1/2"	61	45	110	80	155	115
9/16"	95	60	155	115	220	165
5/8"	128	95	215	158	305	220
3/4"	225	165	390	290	540	398
7/8"	230	170	570	420	880	650
1"	345	225	850	630	1320	970

8.7 Service Record

The period recommended is based on normal operating conditions. Severe or unusual conditions may require more frequent service.

Copy this page to continue record.

Hours and Serviced By														
Maintenance														
Before Each Use														
Make sure all retainer clips and pins are in place.														
Inspect the ground engaging components for wear and damage.														
Grease axle bearing caps (7100 Series).														
Every 50 Hours														
Make sure all fasteners are properly tightened.														
Inspect the disc blades for wear and damage.														
Annually														
Grease axle bearing caps (7100 Series).														
Make sure all fasteners are properly tightened.														
Inspect the disc blades for wear and damage.														
Make sure the 3-point hitch pins and retainer clips are in good condition. Do not use homemade or shop-made pins.														
Inspect the hitch A-frame and braces for wear and damage.														
Wash the disc harrow.														

9. Troubleshooting

PROBLEM	CAUSE	SOLUTION
Disc harrow makes a high center ridge.	Excessive speed.	Reduce speed.
	Rear gangs cut too deep.	Reduce gang angle.
	Top link too long.	Shorten top link.
Disc harrow cuts a furrow (valley) in the center.	Insufficient speed.	Increase speed.
	Rear gangs too shallow.	Increase gang angle.
	Top link too short.	Lengthen top link.
Disc harrow makes ridges on the outside cuts and furrows just inside the ridges.	Too much soil is being thrown out by the front disc gangs.	Raise front disc gangs by lengthening the 3-point top link.
		Reduce front disc gang angle.
Disc harrow makes a furrow on the outside cuts and a ridge just inside the furrow.	Rear disc gangs are set too wide.	Reduce spacing between rear disc gangs.
		Raise front disc gangs by lengthening the 3-point top link.
Disc harrow does not pull straight and/or shifts from side-to-side.	Front disc gangs running deeper than the rear gangs.	Raise front disc gangs by lengthening the 3-point top link.
	Disc gangs are not centered on the frame.	Center the disc gangs on the frame.
Disc harrow leaves a depression in the worked soil behind the tractor wheels.	Tire slippage, heavy tractor, soft soil conditions.	Add duals, increase tractor speed, increase gang angle, and/or increase cutting depth.
		Tilt disc harrow down at the rear by lengthening the 3-point top link.
Disc harrow doesn't operate smoothly.	Disc gang angles are too aggressive.	Use the smallest disc gang angle that will do the job. Make sure rear disc gang angle is less than the front disc gang angle.
Disc harrow doesn't penetrate the soil properly.	Disc gang angles aren't aggressive enough.	Increase disc gang angles. Make sure the front disc gang angle is more than the rear disc gang angle.
Outside front disc blades and/or gang axle is bending or breaking.	Making sharp turns and crossing ditches with the disc harrow in the ground.	Raise disc harrow out of the ground when making turns and crossing ditches. Cross ditches at an angle. Do not cross deep ditches.
	Gang axles becoming loose.	Keep disc gang axle nuts tight.
Rear tractor wheel slippage.	Not enough ballast.	Add weights to tractor.
Plugging.	Extremely wet soil. Gangs set at too great an angle.	Allow soil to dry. Reduce angle.

10. Warranty



LIMITED WARRANTY

IronCraft. (the “Manufacturer”) warrants, only to the original Purchaser, this equipment will be free from defects in material and workmanship, under normal use and service, for one (1) year from the date of purchase providing this equipment is purchased for individual use only. **Commercial use of this equipment is not covered under any warranty.** This warranty does not apply to any equipment which has been damaged or which has been subjected to change, misuse, negligence, abnormal wear and tear, alterations, tampering, or failure to follow operating instructions. This warranty does not cover any product or parts not manufactured by IronCraft.

Under this warranty, the Manufacturer will repair or replace any part which the Manufacturer determines has failed during the period of the warranty due to defects in material or workmanship. After written approval by the manufacturer, the equipment or defective part must be returned to IronCraft.

Warranty coverage and performance is expressly conditioned upon the return of the completed registration form to IronCraft, PO Box 649, Decatur, Tennessee 37322.

IronCraft reserves the right to make improvements and changes in specifications without notice or obligation to modify previously sold units. The Owner’s Manual describes the proper assembly procedures for your implement and furnishes operating and maintenance recommendations to help you obtain long and satisfactory service.

PURCHASER’S EXCLUSIVE REMEDY FOR BREACH OF WARRANTY, OTHER DEFECT, OR CONDUCT GIVING RISE TO LIABILITY SHALL BE THE REPAIR OR REPLACEMENT OF THE PRODUCT SOLD, AND THE MANUFACTURER UNDER NO CIRCUMSTANCES SHALL BE LIABLE FOR ECONOMIC LOSS OR INCIDENTAL OR CONSEQUENTIAL DAMAGES. THE MANUFACTURER DISCLAIMS ALL IMPLIED WARRANTIES, INCLUDING THE WARRANTY OF MERCHANTABILITY AND FITNESS FOR PURPOSE.

Purchaser and IronCraft hereby (a) submit to the non-exclusive jurisdiction of the courts of competent jurisdiction in Meigs County, Tennessee, and the United State District Court for the Eastern District of Tennessee for resolution of any dispute concerning this Limited Warranty or the rights or obligations of Purchaser and/or IronCraft; (b) agree that any litigation commenced in Tennessee in connection with this Limited Warranty shall be venued in either the Meigs County, Tennessee District Court, or the United States District Court, Eastern District of Tennessee, Southern Division, and (c) waive any objection it may have as to any such action or proceeding brought in such court that such court is an inconvenient forum. Nothing herein shall limit the right of Purchaser or IronCraft (or the right of any permitted successor or assign of either) to bring proceedings against the other in the courts of any other jurisdiction wherein any assets of such other party may be located.



WARRANTY REGISTRATION FORM

Disc Harrow

THIS REGISTRATION FORM MUST BE ON FILE WITH IronCraft.
WITHIN **30 DAYS** OF DELIVERY TO PURCHASER, OR WARRANTY CLAIM WILL NOT BE HONORED.

PLEASE COMPLETE REGISTRATION ONLINE

OR RETURN COMPLETED FORM BY E-MAIL, FAX, OR MAIL:

E-MAIL: warranty@ironcraftco.com

FAX: (423) 405-5150

MAIL: PO BOX 649, DECATUR, TN 37322

MODEL: _____ SERIAL #: _____ DELIVERY DATE: _____

TRACTOR MAKE & MODEL BEING USED WITH ABOVE UNIT: _____

PURCHASER'S NAME: _____

ADDRESS: _____

CITY: _____ STATE: _____ ZIP: _____

SELLING DEALER'S NAME: _____

CITY: _____ STATE: _____ ZIP: _____

I have read all warranties and agree with these conditions. I agree to read and follow all safety instructions outlined in this manual before operating this disc harrow.

Purchaser's signature: _____

11. Parts

Replacement parts are available from your authorized Dealer Parts Department.

Visit our website at

<https://www.ironcraftco.com/parts>

to download the latest Parts Lists from IronCraft.

Contact your dealer for more information, or to order your parts.



**P.O. BOX 649
232 INDUSTRIAL LN.
DECATUR, TENNESSEE 37322
PHONE: (423) 405-5150 • FAX: (423) 334-0023
WEB: WWW.IRONCRAFTCO.COM**

Member of

