

IRONCRAFT

Contact your Authorized Ironcraft Dealer
for all your parts needs



PHDT - 650 SERIES POST HOLE DIGGER PARTS MANUAL

650 - PHD Components

Item	Part #	Description	Qty
1	DIGT002	Boom Weldment	1
2	DIGT003	Hitch weldment	1
3	PTOLD650	Driveline – Complete	1
	PPTOLD650G	Driveline shield	1
4	DIGT201	Gearbox	1
	DIGT202	Gearbox Bearing & Seal Kit	1
	AUGT407	Input Seal	1
	AUGT408	Output Seal	1
5	DIGT204	Input Shield	1
	N/A	Hex Bolt M10 x 30	2
	N/A	Lockwasher M10	2
	N/A	Hex Nut M10	2
6	DIGT203	Output Shield	1
	N/A	Hex Flat Screw M10 x 20	2
	N/A	Lockwasher M10	2
	N/A	Hex Nut M10	2
7	DIGT002P	Pin – for Gearbox to Boom	1
	N/A	Cotter Pin 5/32" x 1-1/2"	2
8	DIGT003P	Pin – for Hitch to Boom	1
	150550	Lynch Pin 7/16"	1
9	110032	Link Pin CAT-I with Lockwasher & Nut	2
	150550	Lynch Pin 7/16"	2
10	AUGT006	6" Auger-Complete	A/R
	AUGT009	9" Auger-Complete	A/R
	AUGT012	12" Auger-Complete	A/R
11	AUGT101	Screw on Point with 1-1/4" NC Threads	1
12	AUGT206	6" Cutting Edge	2
	AUGT309	9" Cutting Edge - Outer	1
	AUGT209	9" Cutting Edge – Inner	1
	AUGT312	12" Cutting Edge – Outer	1
	AUGT212	12" Cutting Edge – Inner	1
	NA	Carriage Bolt 3/8"x 1-1/4" – for Auger Tooth	4
	NA	Lockwasher 3/8"	4
	NA	Hex Nut 3/8"	4
13	NA	Bolt 1/2"x 3" or 1/2" x 3-1/2"	1
14	NA	Lockwasher 1/2"	1
15	NA	Hex Nut 1/2"	1
16	NA	Bolt 5/16"x 2-1/2" Grade 5 (Shearbolt for Driveline)	1
	NA	Lockwasher 5/16"	1
	NA	Hex Nut 5/16"	1

A/R = As Required

NA- Common fasteners available through local hardware and farm stores.

650 - PHD Components

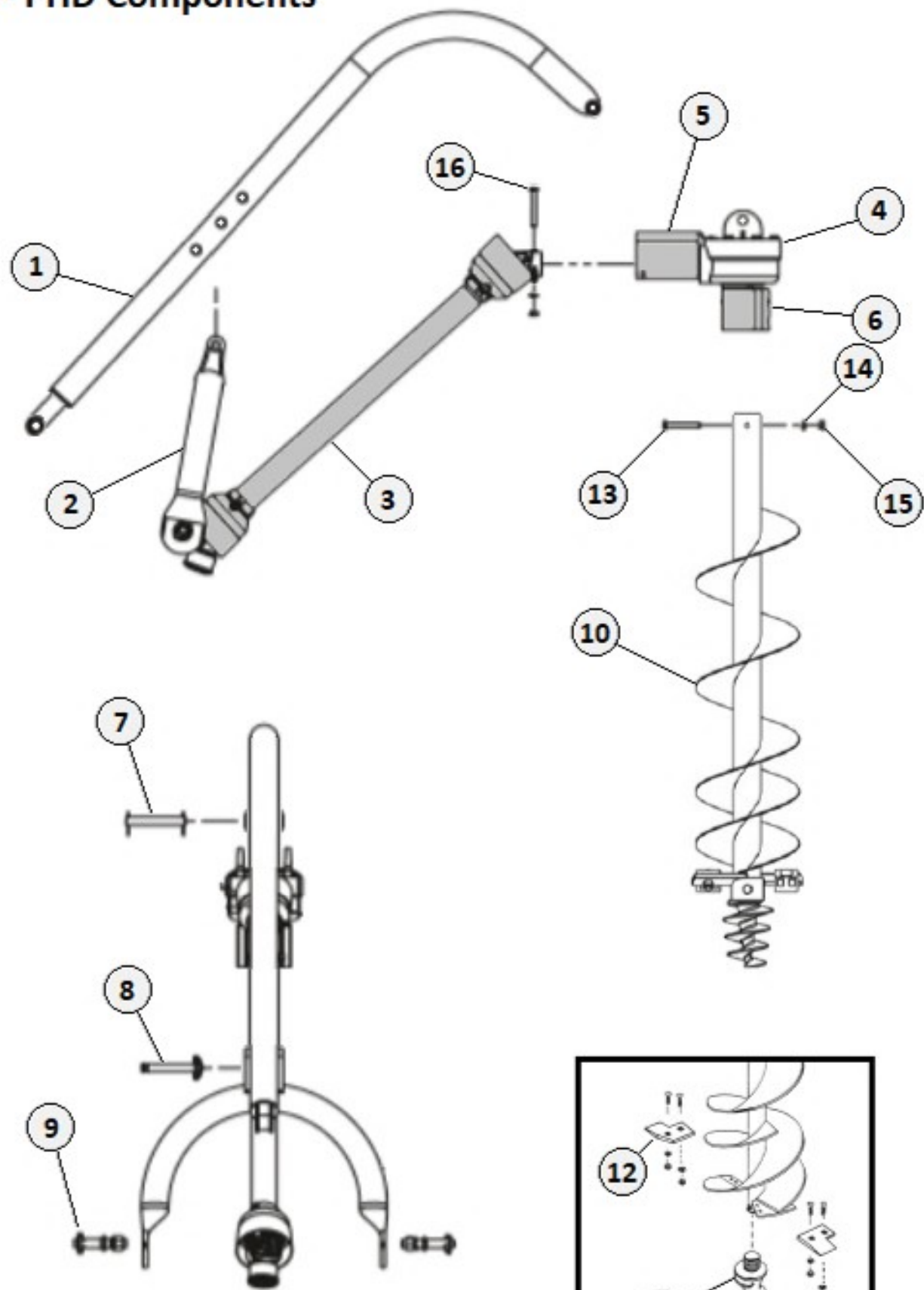

NOTE: Safety shields are shaded on this diagram. NEVER operate the digger with any shield missing.

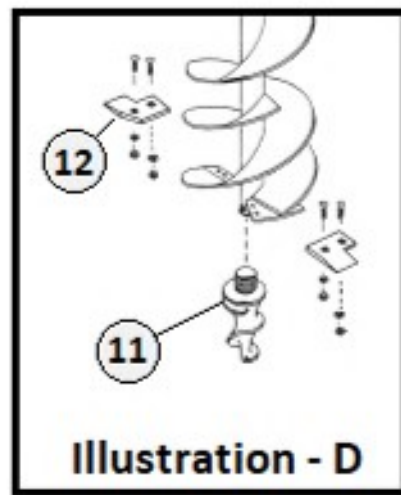

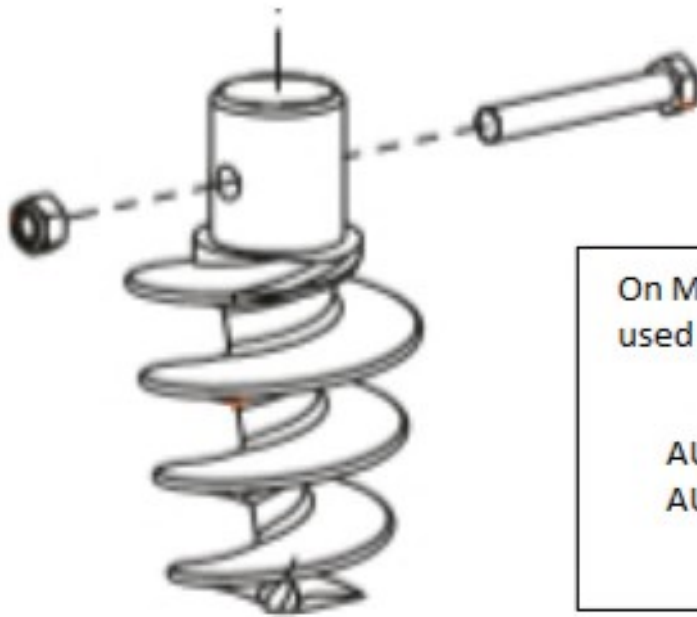

On Model 650 PHD - some augers
used these teeth and center point

AUGT406 H.D. Cutting Edge
AUGT102 Bolt on Center Point