



PHD POST HOLE DIGGERS

OPERATION MANUAL



Read and understand the manual. This manual provides information and procedures to safely operate and maintain the Post Hole Digger.



July 2022

Table of Contents

	Page(s)
Important Safety Information	1-4
Intended Use	1
Personal Protective Equipment	1
Safety Decals	1-3
General Safety and Preparation.....	3
Operating Safety	3-4
Repair and Maintenance Safety.....	4
Assembly Instructions	5
General Maintenance	6
Operating Instructions	6
Parts Breakdown.....	7
Parts Breakdown Illustration	8
Warranty Registration.....	9
Specifications	Back Cover
Ordering Information	Back Cover



IMPORTANT SAFETY INFORMATION



WARNING: Understand all instructions and safety information before assembling or operating this post hole digger. Failure to do so may cause serious injury or death. Do not allow anyone to operate this post hole digger who has not read this manual. As with all power equipment a post hole digger can be dangerous if assembled or used improperly. Do not operate this post hole digger if you have doubts or questions concerning safe operation. Contact our customer service department at info@tooltuffdirect.com to address these concerns.

INTENDED USE

This product is designed to dig holes in the soil when attached to the 3-point linkage system and power-take-off of a tractor.

It is **not** intended for any other use. Using the product for anything other than digging holes could result in serious injury or death.

PERSONAL PROTECTIVE EQUIPMENT



ALWAYS use appropriate personal protective equipment such as protective eyewear, earware, gloves, safety shoes and hard hat when operating this post hole digger.

NEVER wear loose clothing or jewelry that could become entangled in the auger or driveline.

SAFETY DECALS

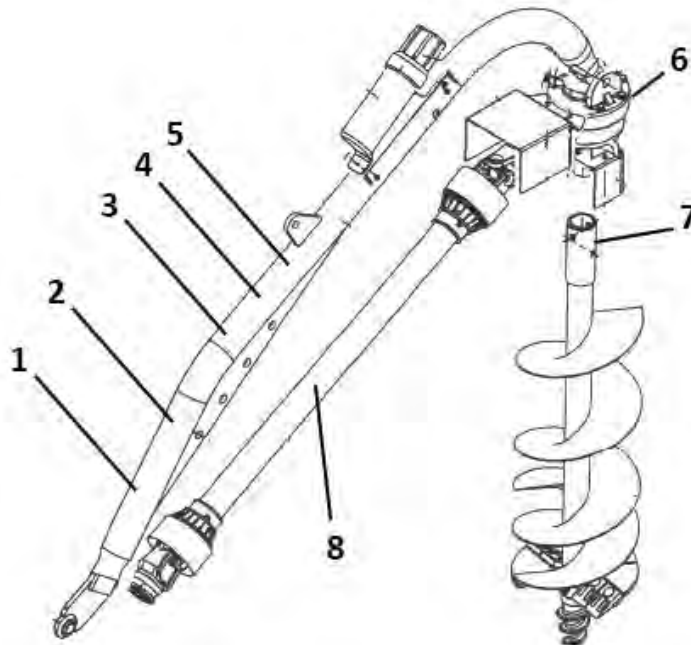

Note:
Not a decal. Model
650 Shown.

Find the decals shown on the next pages and ensure your digger has them. Read and understand the warnings on the decals.



DGDC002
4.5 w x 1.5 h

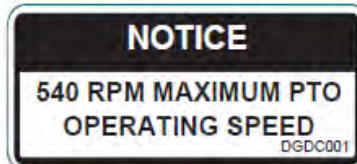

DGDC001
2.7 w x 1.25 H



DGDC003
2.75 w x 3.5 h



DGDC004
2.75 w x 3.5 h



DGDC005
2.75 w x 3.75 h

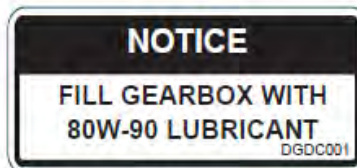

DGDC006
2.7 w x 1.25 H



6 piece safety decal sheet
AgKNX Post Hole Diggers
ToolTuff Direct LLC
15000 W 44th Ave, Ste B
Golden CO 80403
720-437-7640

LOCATION: PTO DRIVE SHAFT
PART NUMBER: DGDC008



IMPORTANT SAFETY INFORMATION

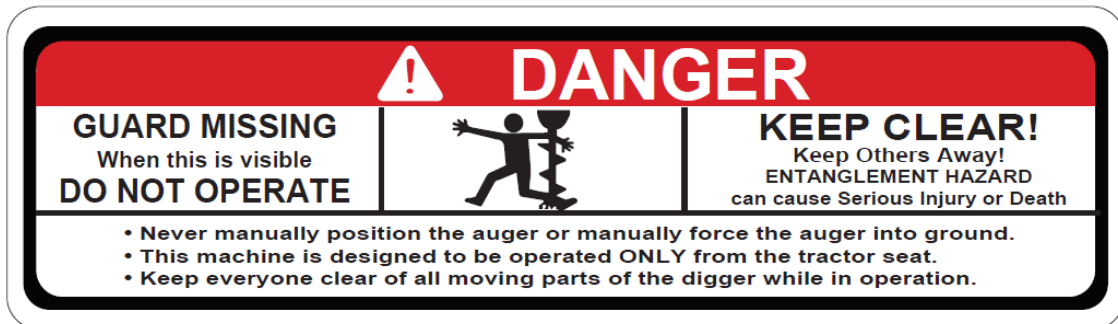

LOCATION: TOP END OF AUGER TUBE
PART NUMBER: DGDC007

NOTE: IF THE OUTPUT SHAFT GUARD MENTIONED IN THE ABOVE DECAL IS MISSING, ORDER A REPLACEMENT BY CONTACTING US AT 423.334.0012

GENERAL SAFETY AND PREPARATION

ALWAYS make sure that anyone else who operates this post hole digger has read and understood the contents of the owner's manual and all safety decals on the product.

ALWAYS be certain that all members of the work party are familiar with the operation of the digger and the hazards associated with it.

ALWAYS check with authorities for underground utilities before digging a hole. Serious injury or death could result from contact with gas or electric lines.

ALWAYS check the tractor owner's manual for instructions on operation, attachment of 3-point equipment and safety.

ALWAYS make sure that all safety shields are in place and tightened down. Do not operate this post hole digger if any shields are missing. Contact IronCraft at 423.334.0012 or sales@ironcraftco.com for replacement part(s).

ALWAYS make sure that the auger point and cutting edges are intact and in good working order before using this digger.

NEVER allow children or other persons to ride on the Tractor or Implement. Falling off can result in serious injury or death.

NEVER allow children to play on or around Tractor or Implement. Children can slip or fall off the Equipment and be injured or killed. Children can cause the Implement to shift or fall crushing themselves or others.

NEVER allow others within 20 feet while operating the post hole digger.

NEVER operate post hole digger without all guards in place.

ALWAYS ensure the driveline is securely locked onto the PTO.



IMPORTANT SAFETY INFORMATION

OPERATING SAFETY

ALWAYS operate this post hole digger from the tractor seat. Only one person should operate the digger.

NEVER attach the post hole digger with the tractor engine running.

NEVER operate the post hole digger with anyone near or in contact with any part of the implement, PTO driveline or auger. Serious injury or death could result from entanglement with moving parts.

ALWAYS make sure that the tractor brake is set before digging a hole.

ALWAYS keep hands, feet and clothing away from power-driven parts during operation.

NEVER manually position the auger or manually force the auger into the ground.

ALWAYS make sure that the tractor engine is shut off and the PTO drive is disengaged before leaving the tractor seat.

NEVER move the tractor with the power-take-off in the ON position.

NEVER exceed 540 RPM PTO operating speed.

NEVER operate the post hole digger when the auger point is more than 6 in. above ground level. Operating the digger in elevated positions may cause the PTO driveline "U" joints to bind resulting in equipment damage and operator injury.

ALWAYS turn off the digger immediately if an immovable object is encountered to prevent damage to the gear box or driveshaft and possible injury. A shear bolt is provided but may become welded to the input shaft if the driveshaft is left running after being sheared.

TRANSPORTATION SAFETY

NEVER allow anyone to ride on Implement.

Make certain the slow moving (SMV) sign and other reflectors are clearly visible. Follow local traffic codes for slow moving vehicles when transporting on public roads.

REPAIR AND MAINTENANCE SAFETY

ALWAYS perform maintenance operations such as lubrication, adjustments or repairs on the post hole digger with the tractor engine off, the PTO drive disengaged and the auger point resting on the ground.

ALWAYS use the correct shear bolt (Grade 5). **NEVER** use or replace the shear bolt with one that is longer than the one specified in the manual (5/16" x 2-1/2").

Periodically inspect all moving parts for wear and replace when necessary with authorized service parts. Look for loose fasteners, worn or broken parts, and leaky or loose fittings. Serious injury may occur from not maintaining this machine in good working order.

Do not modify or alter this Implement. Do not permit another to modify or alter this Implement, any of its components or any Implement function. Any modification will void the warranty.

ASSEMBLY INSTRUCTIONS

IMPORTANT: The gear box is shipped without lubricant. Fill the top hole with **80W-90** lubricant or the equivalent. Fill until the lube appears at the side level check hole. Approximately two pints or two pounds of the lubricant is enough to lubricate the gears and bearings. A greater amount will not harm the gear box. Do not fill to overflow point as this may damage the seals.

STEP 1: Be certain that the gear box has adequate lubrication. Check the oil level after every fifty hours of use.

STEP 2: Attach the boom (1) to the top link mounting bracket on the tractor using a top link pin and a lynch pin (not provided) through the hole at the bottom of the boom.

STEP 3: Connect the "A" frame (5) to the tractor's 3-point lift arms using the 7/8 in. pull pins with nut and lockwasher (5A) as shown in the drawing. Attach the "A" frame (5) to the boom (1) after selecting the desired hole (for angle adjustment) using the "A" frame pin (6) and lynch pin (4).

STEP 4: Attach the gear box (10) to the boom (1) using the boom pin (2). When in place secure with cotter pins (3). NOTE: Input shaft shield (9) and output shaft shield (12) are already attached to the gear box.

STEP 5: Attach the auger (20, 21 or 22) to the output shaft on the bottom of the gear box (10) using the 1/2 in. hex cap screws (17), 1/2 in. lockwashers (18) and 1/2 in. hex nuts (19). Tighten the nuts.

STEP 6: Attach the driveline (13) to the gear box input shaft using the 5/16 in. grade 5 hex cap screw (14), the 5/16 in. lockwasher (15) and the 5/16 in. NC hex nut (16). Tighten the hex nut. Insert the 1/4 in. x 3/8 in. set screw from the hardware kit in the hole on the yoke that aligns with the 3/16 in. groove on the gear box input shaft. Tighten.

ATTENTION: THE 5/16 IN. HEX CAP SCREW PROVIDES SHEAR PROTECTION. USE A GRADE 5 2-1/2" BOLT ONLY TO AVOID DAMAGE TO THE GEAR BOX OR AUGER.

IMPORTANT: The universal joint should be greased with a good grade chassis lube every week. At the beginning of each season grease the sliding driveshaft members with a moly grease. All diggers are equipped with quick-detach universal joints on the power-take-off end for a 1-3/8 in. splined shaft.

STEP 7: Attach the tractor end of the driveline (13) to the tractor PTO shaft. Push in the spring-loaded pin in the splined yoke (13C) and slip it on the splined PTO shaft of the tractor. Release the pin and push until it locks securely in place. It will be necessary to obtain a 1-1/8 in. to 1-3/8 in. sleeve spline adapter if your tractor PTO shaft has a 1-1/8 in. spline.

STEP 8: Attach and secure both chains on the driveline to the boom (1). See illustration A.

STEP 9: Check all nuts and bolts for tightness. Stabilizers should be kept tight to avoid side sway of the digger.

NOTE: See illustration A for reference in assembling the digger and mounting it to the tractor. Note that the boom angle can be adjusted on your tractor for proper digging and ground clearance by moving the "A" frame to a different mounting hole as shown in illustration B.

NOTE: When the 7/8 in. diameter pull pins in the "A" frame are too small for the holes in the lift arms, bushings should be used to obtain a proper fit.



ILLUSTRATION A



ILLUSTRATION B

OPERATING INSTRUCTIONS



WARNING: *Read and thoroughly understand all instructions and safety information before operating this post hole digger. Failure to do so may cause serious injury or death. Do not allow anyone to operate this post hole digger who has not read this manual.*

STEP 1: After mounting the digger to the tractor, lower the auger point slowly to the ground at the desired digging angle before engaging power.

STEP 2: Engage the power-take-off and start digging at a slow speed, lowering the auger slowly as it begins to dig.

STEP 3: Increase speed as the auger goes deeper. The type of soil will determine the proper auger speed. If the soil is extremely hard, it will generally improve operation to vary the speed of the auger at times.

STEP 4: When the auger has reached the desired depth, spin it momentarily at a high speed to clear the hole of dirt. Reduce speed before withdrawing the auger from the hole.

STEP 5: Disengage the power-take-off after withdrawing from the hole and move the tractor to the next hole location.

GENERAL MAINTENANCE

REFER TO ILLUSTRATION C



WARNING: *Always perform maintenance operations with the tractor engine off, the PTO drive disengaged and the auger point resting on the ground.*

1. To remove the auger from the gear box output shaft, take out the two 1/2 in. x 3 in. hex cap screws (17).
2. To remove the driveshaft from the gear box input shaft, take out the shear pin bolt (14) and 1/4 in. set screw (13E).
3. Check the oil level after every fifty hours of use. Use 80W-90 lubricant and fill to oil level plug. All replacement lubricant should be of this type.
4. The universal joints should be greased with a good grade chassis lube every week. At the beginning of each season, grease the sliding driveshaft members with a moly grease.

Registration

WARRANTY VOID IF REGISTRATION IS NOT MAILED WITHIN 15 DAYS OF RECEIVING ITEM.

Fill out this page and mail to the address below.
warranty@ironcraftco.com

Digger Model # _____

Purchase Date ____/____/____

Purchased From: _____ Purchaser: _____

Owner's Address: _____

City: _____ ST: _____ Zip Code: _____

Phone: _____ Email: _____

Attach a Copy of Proof of Purchase

Acceptance of responsibility:

I (Purchaser) have read operators manual and Limited Warranty or someone has read/and explained all instructions to me. I understand this warranty does not cover any labor and that all disputes will be settled by binding arbitration. Warranty void if any attempt to repair or replace defective parts has been made by unauthorized personnel. I have received my Owner's Manual and fully understand the stipulations. The mark next to each item below confirms my acceptance of responsibility for the use and maintenance of this Post Hole Digger. I understand that I alone am responsible for proper maintenance, care and safe operation of this Post Hole Digger.

- Received and read or will read prior to use the Operators Manual, specifically the safety warnings
- Specifications accepted
- Controls understood
- Maintenance Requirements understood
- Storage of Digger

I (purchaser) also understand that persons not familiar with the operation of this equipment should not be allowed to use it. Children especially should not operate or be near equipment. ANYONE OPERATING EQUIPMENT SHOULD HAVE READ ALL EQUIPMENT OPERATIONS MANUALS AND SAFETY MANUALS.

Is this Post Hole Digger used in a business NO YES If yes, business type: _____

Owners Signature: x _____ Date: ____/____/____

It is recommended that a copy of the registration be given to the seller.

You must sign this warranty and mail copy to **P.O. Box 649, Decatur, TN 37322**. This warranty is not effective unless the Purchaser mails this Registration and Warranty Form **within 15 days of purchase**. NOTE: The Manufacturer may refuse

warranty of any kind unless IronCraft receives a completed, legible and signed warranty registration. It is the responsibility of the purchaser to assure that this registration document is received by IronCraft



**P.O. BOX 649
232 INDUSTRIAL LN.
DECATUR, TENNESSEE 37322
PHONE: (423) 405-5150 • FAX: (423) 334-0023
WEB: WWW.IRONCRAFTCO.COM**

Member of

