



**CID**

**ATTACHMENTS**

# ALL HAY SPEARS

SLM OWNER'S MANUAL

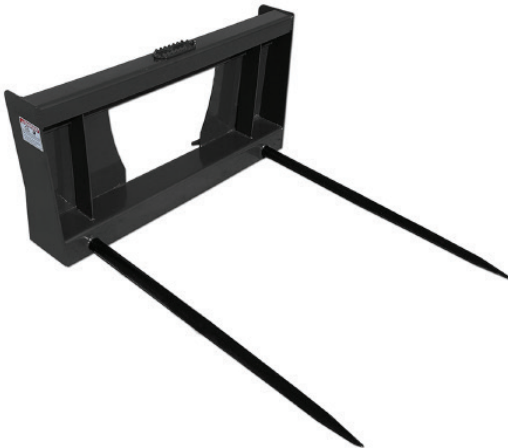

**LOW BACK**

**DOUBLE  
ADJUSTABLE**

**HIGH BACK**

DEC  
2024

OPERATING INSTRUCTIONS | SAFETY RULES | MAINTENANCE PROCEDURES

## REGISTER YOUR PRODUCT

<b>CID</b>	WWW.CIDATTACHMENTS.COM	<b>336-859-2002</b>
MODEL	<input type="text"/>	WEIGHT <input type="text"/>
PART	<input type="text"/>	HP RANGE <input type="text"/>
SERIAL	<input type="text"/>	
HYDRAULIC PRESSURE	<input type="text"/>	HYDRAULIC FLOW <input type="text"/>

Please see Page 9 for instructions of where to find your model and serial number.

### **WARNING**

To prevent personal injury or even death, be sure you read and understand all the instructions in this manual and other related OEM equipment manuals! This attachment is designed for the purpose specified. DO NOT modify or use this attachment for any application other than that for which it was designed.

**T**hank you for choosing CID. This attachment has been designed and manufactured to meet the needs of discerning users. We are committed to providing you with a heavy duty product that will provide years of satisfaction and safe operation.

This manual will provide instructions on how to safely operate and maintain this attachment. All users must read and understand this manual before operating this attachment. Upon reading this manual, all users should sign the "Safety Acknowledgment Form" at the end of this manual.

Please record your model and dealer information on the inside front cover. You will be asked to provide this information when ordering parts or requesting service. If you need more information on this product, contact your local dealer or visit [www.cidattachments.com](http://www.cidattachments.com).

*Sincerely, Cid Attachments*



# TABLE OF CONTENTS

- INTRODUCTION.....2**
- SECTION 2 HAY SPEAR MODELS**
  - 2.0 Low Back Hay Spears.....4-5
  - 2.0 High Back Hay Spears.....5-6
  - 2.0 Double Adjustable Hay Spear.....6
- SECTION 3 BASIC SAFETY AND OPERATING PROCEDURES**
  - 3.0 Safety Terms.....7
  - 3.1 Safety Symbols & Decals.....8-9
  - 3.2 Skid Loader Requirements.....10
  - 3.3 Personal Protective Equipment.....10
  - 3.4 Federal Law & Regulations.....10
  - 3.5 Safety Instructions.....11
- SECTION 4 OPERATING PROCEDURES**
  - 4.0 Unpacking Your Hay Spear.....12
  - 4.1 Pre-Operating Checklist.....12
  - 4.2 How To Connect Attachment .....12-13
  - 4.4 Disconnecting Attachment.....14
  - 4.5 Operating Guidelines.....14
- SECTION 5 MAINTENANCE PROCEDURES**
  - 5.0 Maintenance Overview.....15
  - 5.1 Maintenance Log Instructions.....16
  - 5.2 Storage Tips.....16
  - 5.3 Torque Specifications Table & Instructions.....17
  - 5.4 Torque Equipment Requirements.....17
  - 5.5 Replacing Hay Spear.....18
- SECTION 6 TROUBLESHOOTING**
  - 6.0 Troubleshooting Chart.....19
- SECTION 7 PARTS INFORMATION**
  - 7.0 Hay Spear Parts Diagram.....20
- SECTION 8 WARRANTY INFORMATION**
  - 8.0 Warranty Statement.....21-22
  - 8.1 Warranty Return Authorization Policy.....22
  - 8.2 Warranty Procedure.....23
- SECTION 9 SAFETY ACKNOWLEDGMENT & MAINTENANCE LOG**
  - 9.0 Safety Acknowledgment & Maintenance Log.....24

Disclaimer: Any critical changes made to this manual by individuals outside the manufacturer’s authorized personnel are doing so at their own risk. The manufacturer cannot be held legally responsible for any consequences, damages, or liabilities resulting from such modifications. It is advised to adhere strictly to the original manual provided by the manufacturer for optimal performance, safety, and reliability.

# SECTION 2

## HAY SPEAR MODELS

SINGLE - LOW BACK HAY SPEAR

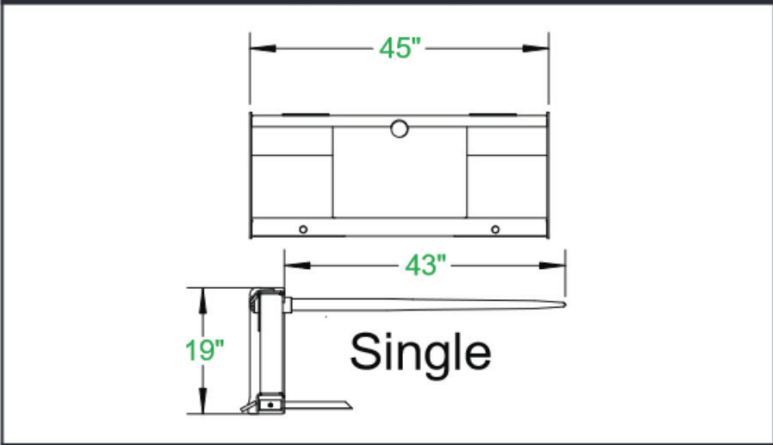

DOUBLE - LOW BACK HAY SPEAR

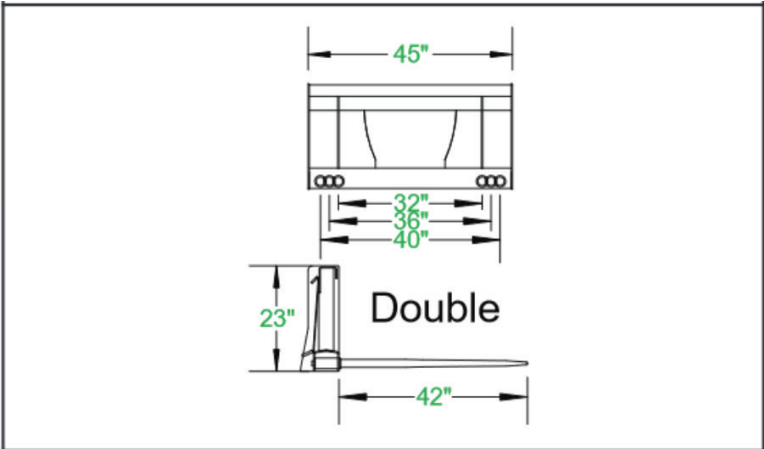
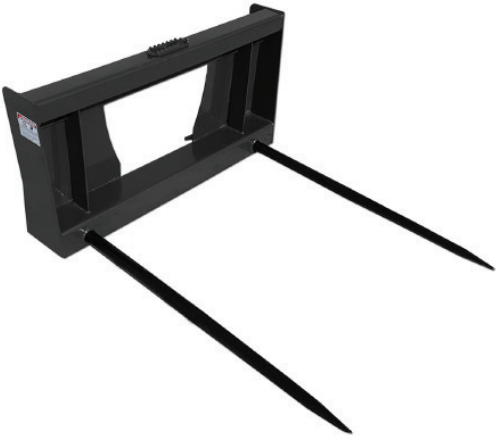

TRIPLE - LOW BACK HAY SPEAR

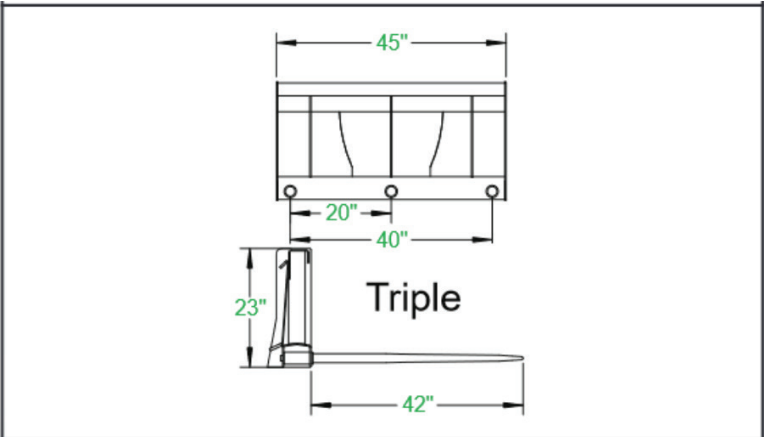
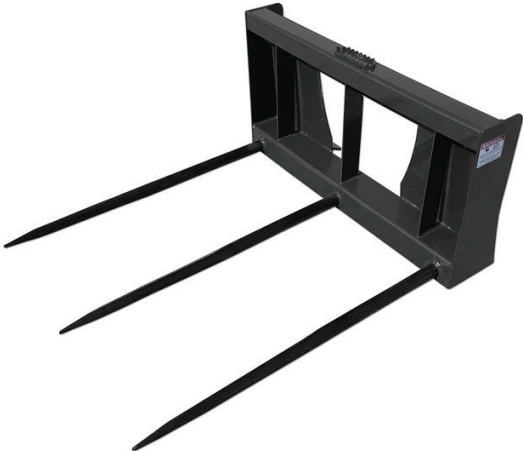

## 2.0 HAY SPEAR MODELS

### QUADRUPLE- LOW BACK HAY SPEAR

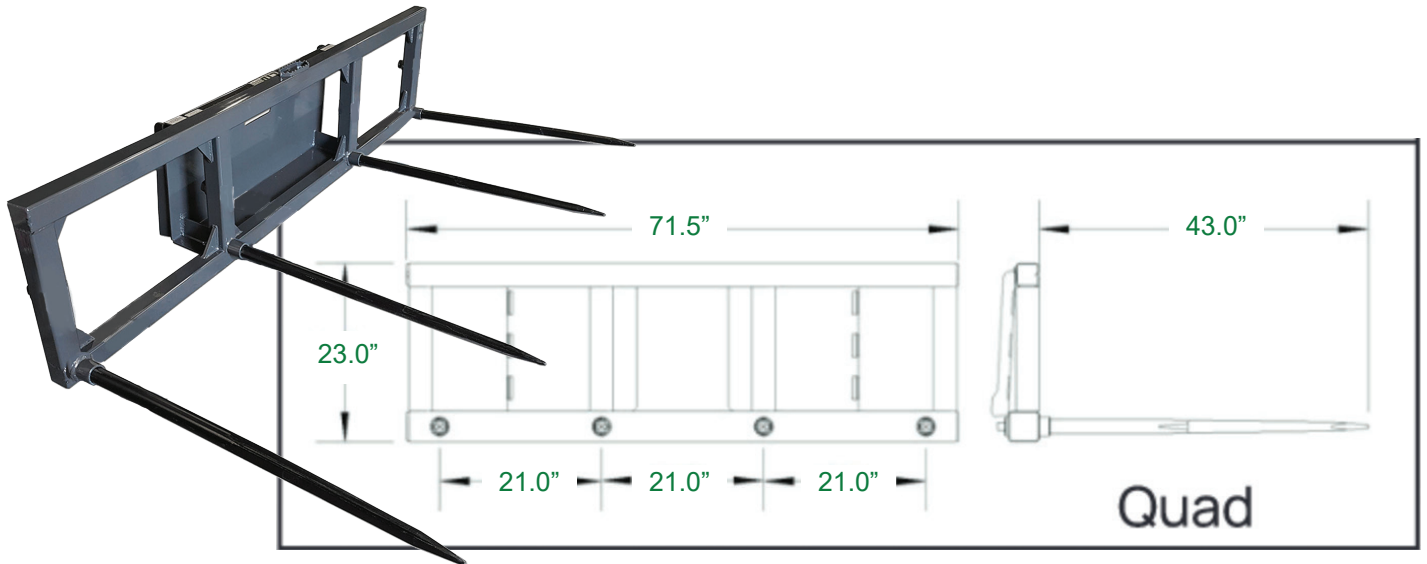

### SINGLE - HIGH BACK HAY SPEAR

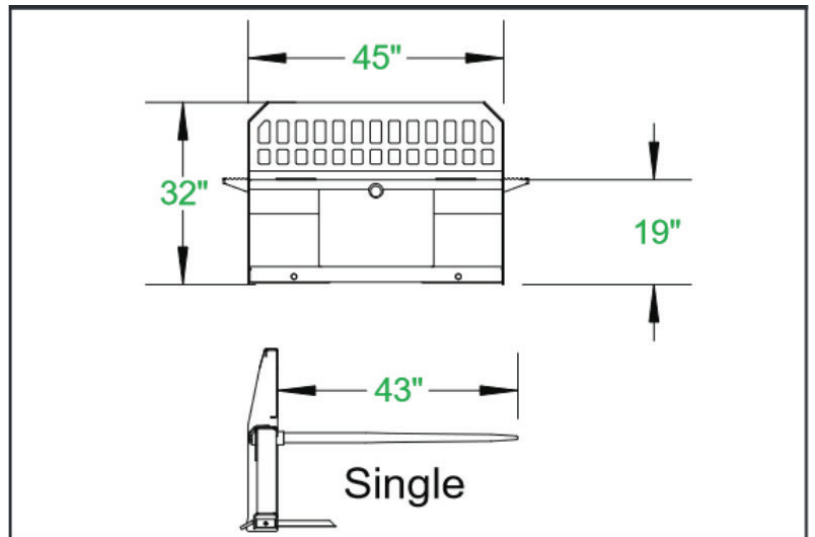

### DOUBLE - HIGH BACK HAY SPEAR

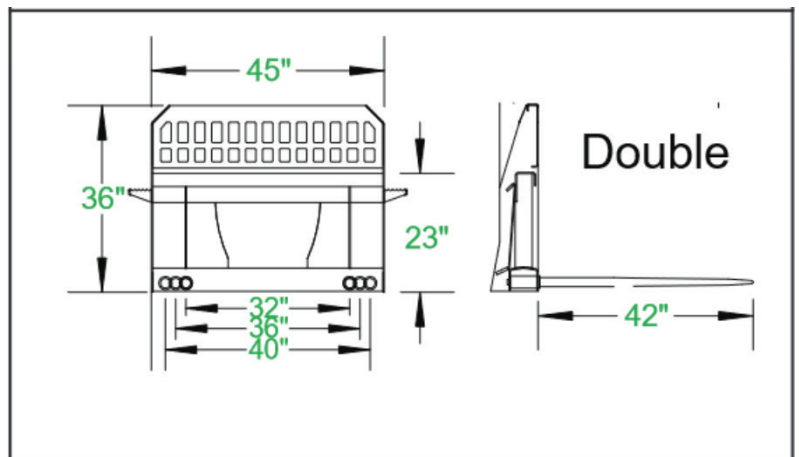

## 2.0 HAY SPEAR MODELS

### TRIPLE - HIGH BACK HAY SPEAR

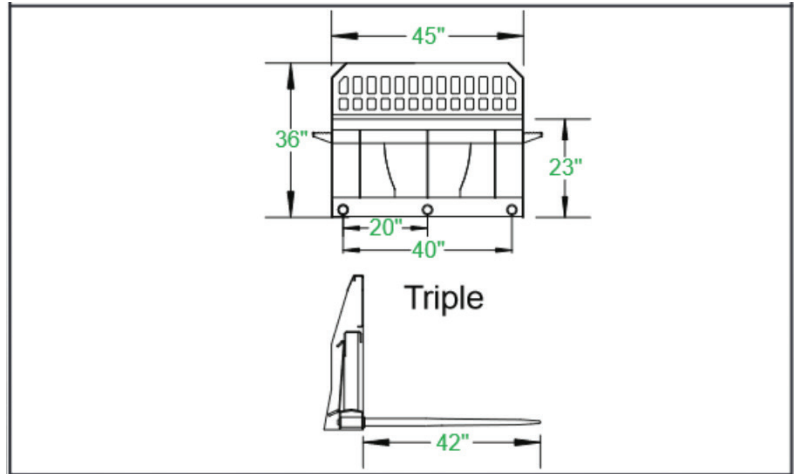

### DOUBLE ADJUSTABLE HAY SPEAR

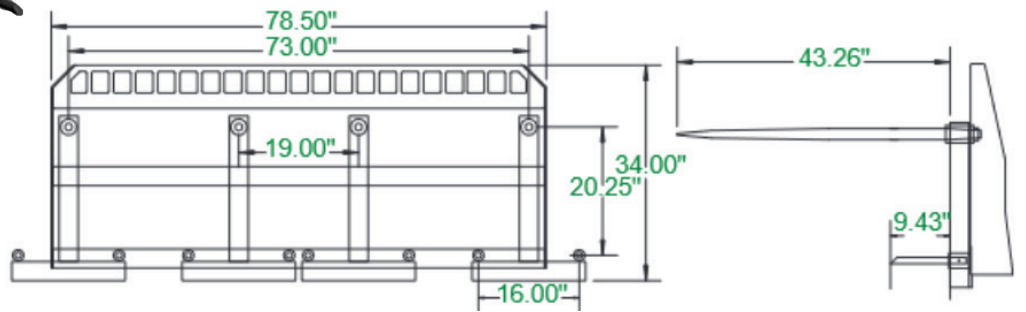

# SECTION 3

## SAFETY AND OPERATION

The following terms may be used interchangeably throughout this manual.

Term	Alternate Terms Used
Hay Spear	implement, attachment, product, hay spear, bale spear
Machine	skid steer loader, skid steer tractor, loader, prime mover, host machine, skid steer
Operator	user, personnel

This **Hay Spear** is designed and manufactured with safety in mind. However, improper use and operator error can result in death or serious injury. It is important that you read and fully understand the safety instructions and operating procedures presented in this manual before operating this attachment. Accident prevention is a combination of good judgment, common sense, awareness and proper training!



**BEFORE YOU OPERATE THIS HAY SPEAR:**

KNOW how to safely operate your machine.

READ and UNDERSTAND the safety instructions and operating procedures contained in this manual.

ACKNOWLEDGE your understanding of all safety instructions presented in this manual by signing the "Safety Acknowledgment Form" at the end of this manual.

Although every effort has been made to ensure a safe product, every possible circumstance that could pose a potential hazard cannot be anticipated. The warnings presented in this manual and on this product, are therefore not all-inclusive.

In addition to the safety messages presented in this section, you must also read and understand the safety messages presented in the other sections of this manual.

### 3.1 SAFETY SYMBOLS & DECALS

This manual and the decals on this attachment use safety symbols, hazard labels, pictograms and color coded signal words to alert you to potential hazards that may cause severe injury or death if a safety instruction is ignored.



**SAFETY ALERT SYMBOL** - This symbol is used to alert you to potential personal injury hazards. Obey all safety messages that follow this symbol to avoid possible injury or death.

#### HAZARD CLASSIFICATIONS

Hazards are identified by the “Safety Alert Symbol” and followed by the signal word “DANGER”, “WARNING”, or “CAUTION”.

**! DANGER**  
Indicates an imminently hazardous situation which, if not avoided, will result in death or serious injury. This signal word is limited to the most extreme situations.

**! WARNING**  
Indicates a potentially hazardous situation which, if not avoided, could result in death or serious injury.

**! CAUTION**  
Indicates a potentially hazardous situation which, if not avoided, may result in minor or moderate injury.

**NOTICE**  
Indicates a situation which may cause damage to equipment or property. Messages are not related to personal injury.

**Safety Instructions**  
Indicates specific safety-related instructions or procedures.

Pictogram	Description
	<b>OPERATING MANUAL:</b> Operators must read and understand the safety instructions in the operating manual to prevent death or serious injury.
	<b>EYE PROTECTION &amp; CARDBOARD:</b> Operators and Maintenance personnel must wear proper eye protection and use cardboard or wood to investigate hydraulic leaks to prevent death or serious injury from being injected with high pressure hydraulic fluid.
	<b>HIGH PRESSURE FLUID INJECTION HAZARD:</b> Operators and Maintenance personnel must not place fingers or hands directly over a hydraulic leak to prevent death or serious injury from being injected with high pressure hydraulic fluid.
	<b>NO BYSTANDERS:</b> DO NOT operate this attachment near bystanders. Bystanders must stay back at least 300 feet from the attachment to prevent death or injury from objects being thrown.
	<b>CRUSH HAZARD:</b> DO NOT place any part of the body under the attachment or machine to prevent death or serious injury from being crushed .





### 3.1 SAFETY SYMBOLS & DECALS

The safety decals affixed to this attachment are to keep you safe. DO NOT ignore these decals.



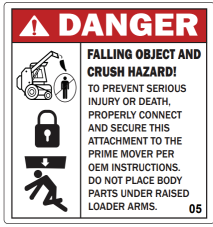

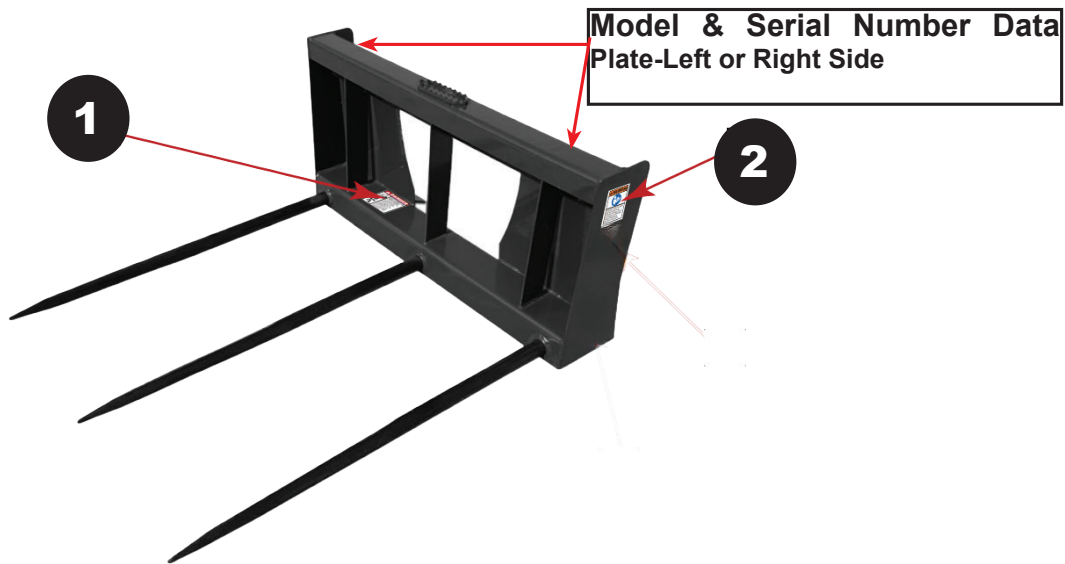

Read and understand each decal's safety message. Follow these Safety Decal Instructions:

*\*WHEN ORDERING, CHOOSE THE PROPER DECAL FOR YOUR MODEL*

REF	DESCRIPTION	LABEL	QTY
1	DANGER-Falling Object/ Crushing Hazard (CID-05)		1
2	WARNING: Read Manual (CID-10)		1



#### CONTACT YOUR LOCAL DEALER TO ORDER REPLACEMENT DECALS

-  Decals must be kept clean and legible at all times.
-  Operators must inspect the attachment for safety decals.
-  Replace missing, worn or damaged decals immediately.
-  When using a hot pressure washer to clean this attachment make sure
- water jet is not too close to the decal as this may cause the decal to peel.
-  When replacing parts, be sure safety decals are in place prior to using the attachment.
-  Make sure metal surface is dry and free of dirt and grease before affixing decals to this attachment.

### 3.2 SKID STEER LOADER REQUIREMENTS

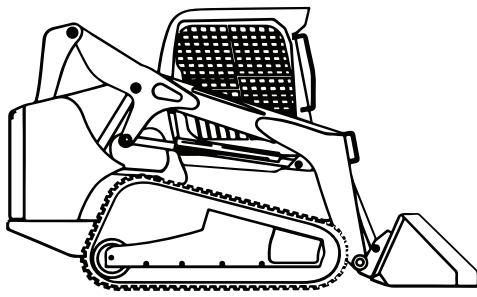

Tracked

VS.



Wheeled

A Tracked Skid Steer or Compact Track Loader (CTL) will provide superior stability in this application.

#### **! CAUTION**

Make sure your machine is in good operating condition. Follow the operating instructions found in the operator's manual. Failure to do so could result in minor or serious injury.

**Consult the host machine's rated operating capacity to ensure you have the proper lift capacity for optimal operation of your attachment.**

**Flow range MUST support the attachment.**

### 3.3 PERSONAL PROTECTIVE EQUIPMENT (PPE)

All operators should wear hearing protection, safety glasses, hand protection and dust mask while operating this attachment.



### 3.4 FEDERAL LAWS & REGULATIONS

#### OSHA REGULATIONS

Current OSHA regulations state in part: "At the time of initial assignment and at least annually thereafter, the employer shall instruct every employee in the safe operation and servicing of all equipment with which the employee is, or will be involved." These will include (but are not limited to) instructions to:

Keep all guards in place when the machine is in operation;

Permit no riders on equipment;

Stop engine, disconnect the power source, and wait for all machine movement to stop before servicing, adjusting, cleaning, or unclogging the equipment, except where the machine must be running to be properly serviced or maintained, in which case the employer shall instruct employees as to all steps and procedures which are necessary to safely service or maintain equipment.

Make sure no one is within 300 feet of machinery before starting the engine, engaging power, or operating the machine.

### 3.5 GENERAL SAFETY INSTRUCTIONS



**MAKE SURE YOU FOLLOW THE GENERAL SAFETY INSTRUCTIONS THAT RELATE TO THE OVERALL OPERATION AND MAINTENANCE OF THIS ATTACHMENT. IT IS IMPORTANT THAT YOU READ AND UNDERSTAND EACH OF THESE MESSAGES TO PREVENT SERIOUS INJURY OR DEATH.**

- !** NEVER use drugs or alcoholic beverages while operating or servicing this attachment.
- !** ALWAYS operate this attachment during daylight or well-lit areas.
- !** We recommend using a high strength clear protective door panel when using with this attachment.
- !** To prevent the machine and attachment from rolling forward, stop the engine and set the parking brake when exiting the machine.
- !** Inspect attachment for loose or missing hardware prior to using this machine.
- !** ALWAYS watch for overhead power lines.
- !** DO NOT place any part of your body under this attachment.
- !** NEVER operate this attachment when bystanders are within 300 feet of your work area. Falling debris could cause serious injury or death.
- !** NEVER position your body or limbs under an unsupported attachment.
- !** DO NOT allow this attachment to contact buildings, utilities, large rocks or tree stumps or you may lose control of the machine.
- !** DO NOT allow children to play on or around this attachment at any time. Store this attachment in an area not frequented by children.
- !** ALWAYS wear the proper personal protection equipment while operating or servicing this attachment. NEVER operate or service this attachment with bare feet, sandals, or other light footwear.
- !** ALWAYS wear work gloves when handling this attachment to protect your hands.
- !** ALWAYS use eye protection while operating or servicing this attachment.
- !** DO NOT operate this attachment during lightning or severe weather conditions.
- !** DO NOT allow riders on the machine or on this attachment.
- !** ALWAYS call 811, the "Digger's Hotline" before digging to identify underground utilities to avoid an accident that could result in Death or Serious Injury to the operator.
- !** DO NOT speed! Speed Kills! Keep your driving speed between 2 and 5 mph.

# SECTION 4

## OPERATING PROCEDURES

Your attachment arrives from the factory strapped to a wood pallet and requires no final assembly.

Use a steel band cutting tool to remove the steel straps.

### CAUTION

Shipping straps are under great tension, and could lash out uncontrollably when cut causing injuries to your body or bystanders. Keep bystanders away and wear safety glasses and gloves while removing the steel straps.

#### 4.1 PRE-OPERATING CHECKLIST

Pre-Operating Checklist	
<input type="checkbox"/>	Hay Spear is securely attached to the machine and pins are locked.
<input type="checkbox"/>	Hay Spear is in working condition and securely attached to the machine and all bolts and nuts are tight.
<input type="checkbox"/>	Safety labels are present and legible.
<input type="checkbox"/>	No material, rope, wire, etc. is obstructing the machine or hay spear.
<input type="checkbox"/>	The area of operation is clear of bystanders and any obstacles that could damage the equipment or injury to the operator.
<input type="checkbox"/>	The operator is of good health and not under the influence of any mind altering substances or alcohol.
<input type="checkbox"/>	Check the machine's hydraulic fluid level and add manufacturer recommended fluid if necessary.

#### 4.2 HOW TO CONNECT HAY SPEAR ATTACHMENT

### DANGER

NEVER enter the area underneath the coupler or any part of the attachment when it is in the raised position to avoid an accident that will result in Death or Serious Injury!

#### GENERAL ATTACHMENT METHOD

Refer to your machine's manual for specific instructions on how to connect and disconnect your attachment. See *figure 4.2c*.

## 4.2 HOW TO CONNECT HAY SPEAR ATTACHMENT

This attachment method refers specifically to skid steers. For all other attachment instructions, refer to the Original Equipment Manufacturer (OEM) for instructions.

1. Make sure the locking pins on the skid steer quick attach mechanism are in the unlocked position.
2. Drive the skid steer to the attachment plate and tilt the skid steer coupler forward and hook the top edge of the skid steer quick attach mechanism under the lip of the hay spear's attachment plate. See figure 4.2a below.
3. Slowly raise and tilt back the skid steer mounting plate, moving upward until the hay spear's attachment plate is flat against the skid steer quick attach mechanism. See figure 4.2a below.

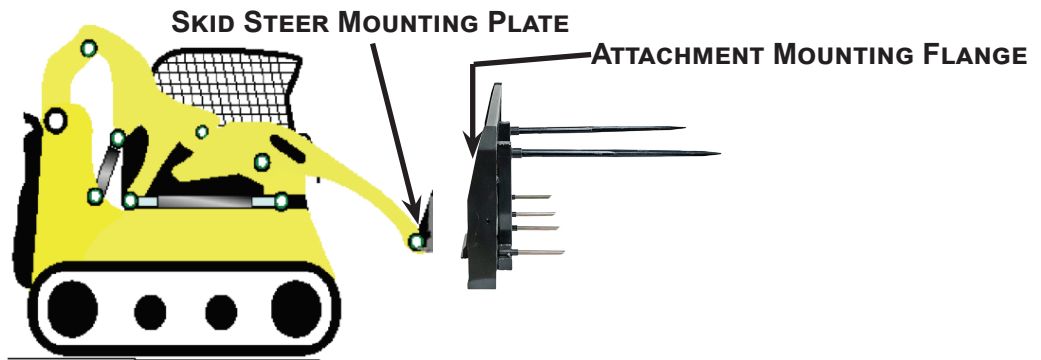

**FIGURE 4.2A - SKID STEER MOUNTING PLATE TO ATTACHMENT MOUNTING FLANGE**

4. Activate your skid steer's lever lock switch to engage and lock the pins into the flange slots of the hay spear's attachment plate. If your skid steer does not have this switch, push the latch handles down until you can see the lock pins extend into the attachment flange as shown in Figure 4.2b below.

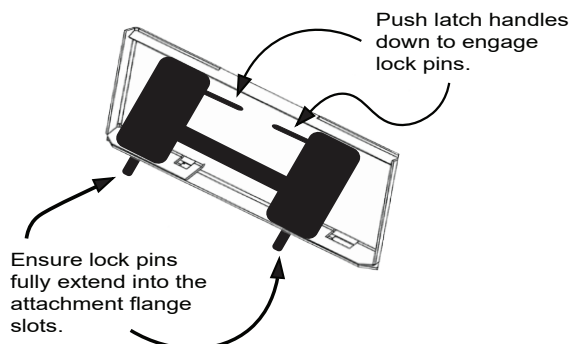

**FIGURE 4.2B QUICK ATTACH COUPLER LOCKED TO ATTACHMENT PLATE**



**FIGURE 4.2C TRACTOR PIN ON HOOKUP**

### **! WARNING**

To avoid serious injury or death, ensure coupler pins fully extend through the slots on the attachment bracket and that levers are down in the locked position to prevent hay spear from detaching from machine.

## 4.3 HOW TO DISCONNECT HAY SPEAR

1. Park machine on a flat and level surface then lower hay spear to the ground.
2. Set parking brake and disengage lock pins using the lock lever switch (if installed).
3. Turn off machine engine.
4. Pull latch handles to disengage lock pins.
5. Re-enter cab and start machine engine.
6. Tilt mounting coupler forward until Quick Attach Coupler is free from mounting bracket.
7. Drive machine backward to clear attachment.



## 4.4 OPERATING GUIDELINES

### **! DANGER**

To prevent death from electrocution, NEVER operate this attachment near electrical wires or cables.

1. ALWAYS inspect the work area before starting the job. Locate and mark any utilities (also turn utilities off), steel posts, rocks or any other objects that could be damaged or could damage this attachment during operation.
2. NEVER assume the work area is safe and skip the inspection before start of operation.
3. Operate at a safe slow-paced speed that will allow you to watch the area ahead and behind the attachment and machine.
4. VERIFY that your back-up alarm and/or camera are working properly to warn others when you are in reverse, but NEVER think that the alarm or camera replaces your responsibility to visually check what is behind you.
5. Attachment control is the most important element to getting a good steady work flow. Overloading the attachment will only result in spinning the tracks or tires and will make unwanted ruts.
6. If you lift or push too heavy of a load with your attachment, you may further reduce your tractive power or cause unstable lifting or moving conditions.
7. Before beginning your forward motion with your attachment, stop the machine and make any final adjustments to the attachment for weight and height.
8. When picking up objects with your attachment, make sure you center your load. Estimate the load center and pick up accordingly, reposition your grab and retry if needed. An unbalanced load could flip your machine.
9. When using your attachment, make sure that you can visually see your load. Beware of pushing or pulling down trees or any type of structure in which you cannot visually see the process.
10. Keep your machine and attachment away from any type of utility, whether underground or in the air.



# SECTION 5

## MAINTENANCE PROCEDURES

The maintenance procedures described in this manual should only be carried out by qualified mechanics who have been trained to repair this attachment.

Some procedures require special tools and skills to complete. **DO NOT** attempt to repair or perform service work on this attachment unless you have the skills and tools to do so. Contact your local dealer for maintenance and repair services.

### **WARNING**

### **PARTS**

Only use genuine Original Equipment Manufacturer (OEM) replacement parts on this attachment. We will not be liable for any damages or injuries caused by the use of after market parts on this attachment.

### **NOTICE**

Improper maintenance or modifications to the design or performance of this attachment will void the warranty. **ONLY** use genuine OEM replacement parts on this attachment.

### **Safety Instructions**

Obey the following safety instructions when servicing or repairing this attachment.

 **Wear proper Personal Protective Equipment (PPE) while working on this attachment, which may include safety glasses, hard hats, steel toe boots, gloves, etc.**

 **If servicing is performed while the hay spear is attached to the machine, turn engine off, set parking brake and chock wheels to prevent machine from moving.**

 **Ensure all jack stands, lifts and hoists are in good working condition and have the rated load capacity to support the load.**

 **Only perform service work in a well-lit area.**

 **Allow the attachment to cool down before servicing this attachment.**

 **NEVER work under an unsupported attachment.**

### **WARNING**

**Hazardous dust can be generated if painted surfaces are heated or welded and could result in Death or Serious Injury. Remove paint before welding and always make repairs in a well-ventilated area and wear an approved respirator.**

## 5.1 MAINTENANCE LOG INSTRUCTIONS



# MAINTENANCE LOG

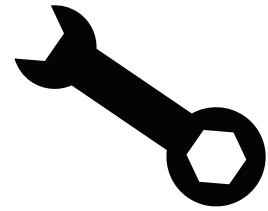

Use the log sheets on at the end of this manual to document all routine maintenance and repair services performed on this attachment.

### 10. MAINTENANCE



#### MAINTENANCE LOG

DESCRIPTION OF MAINTENANCE/REPAIR	SERVICED BY:	DATE:
<i>Replace Filter Blaker</i>	<i>Joe Smith</i>	01/24/24
<i>Inspect Hydraulic Plumbing</i>	<i>Joe Smith</i>	02/25/24
<i>Change Oil in Bearing Housing</i>	<i>Joe Smith</i>	04/24/24

### DANGER

ONLY service the hay spear on stable, even terrain. NEVER park on sloped terrain to avoid being struck & killed or seriously injured by the unexpected rolling or movement of the machine.

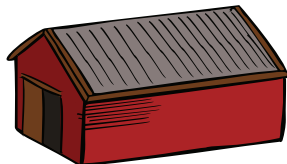
## 5.2 STORAGE TIPS

	<p>Ensure hay spear is free of debris, dirt and grease.</p>
	<p>Store your hay spear in a dry shed or garage.</p>
	<p>When storing your hay spear for the season, cover with a weather proof tarp to protect it from the elements.</p>



## 5.3 TORQUE SPECIFICATION TABLE AND INSTRUCTIONS

### BOLT TORQUE INSTRUCTIONS

1. Apply and maintain proper torque on all bolts.
2. Torque values are based on lubricated values. **Do not grease or oil bolts.**
3. Wipe bolts clean and use Loctite 635 or equivalent before tightening bolts. May need curing activator.
4. Use a torque wrench to assure the proper amount of torque is being applied to the bolt.
5. **MUST CURE 72 HOURS BEFORE USE TO PREVENT LOOSENING OF BOLTS.**

### TORQUE VALUES

#### SAE GRADE 8

	DRY	LUBRICATED
	lb.-ft.	lb.-ft.
1/4"	12	9
5/16"	24	18
3/8"	45	35
1/2"	110	80
3/4"	380	280
7/8"	600	450
1"	910	680
1 1/4"	1820	1360
1 1/2"	3162	2688

## 5.4 TORQUE EQUIPMENT REQUIREMENTS

### TOOLS & EQUIPMENT REQUIREMENTS

To complete the maintenance procedures described in this section, you may need the following tools:

- 1/2 inch drive breaker bar
- 3/4 inch impact socket
- 1/2 inch impact socket
- Tapping Hammer
- 1/2 inch drive torque wrench
- Nylon pry bar set
- Safety stands
- **Loctite 635 or Equivalent-MUST CURE 72 HRS**
- Lifting device (overhead crane hoist, forklift)



#### NOTE:

When removing bolts with Loctite, it will be necessary to apply localized heat of at least 250 degrees Celsius or to 482 degrees Fahrenheit to loosen bolts.

**LOCTITE 635 TECHNICAL SPECIFICATIONS FOR BONDING, CURING, REMOVAL AND INSTALLATION CAN BE FOUND HERE:**

<https://next.henkel-adhesives.com/>

## 5.5 REPLACING A HAY SPEAR

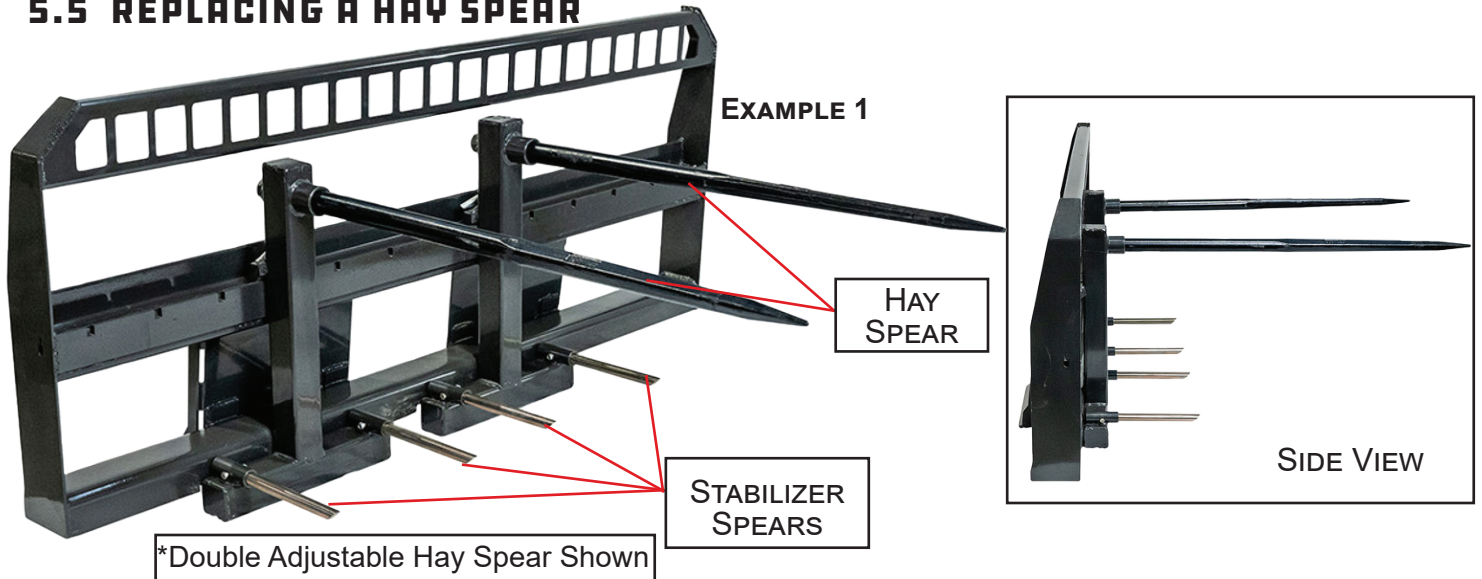

### HOW TO REPLACE A HAY SPEAR

1. Using the machine controls, position the attachment on the ground or other safe and stable spot to access the hay spears. *See Example 1*
2. Power off machine and make sure lift arms are in the locked position to prevent serious injury or death.
3. Remove the nut to the hay or stabilizer spear being removed. *See Example 2*
4. Remove the hay spear.

5. Lubricate the socket that the new hay spear will be inserted into. *See Example 3*

6. Insert hay spear and place the finely threaded conical nut that has a thread designation of M28x1.5". Torque to the specifications listed on page 17. *See Example 4*

7. Follow the same steps (3-6) for the hay spear stabilizer spear.

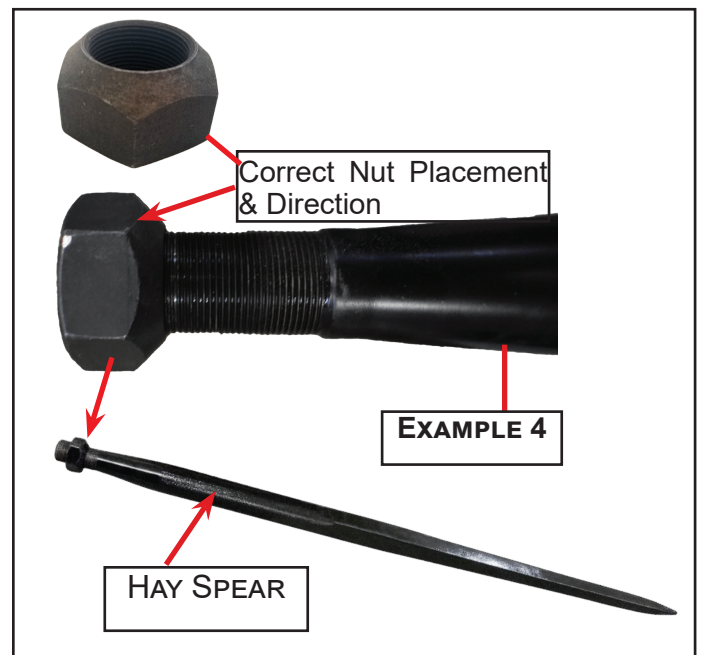
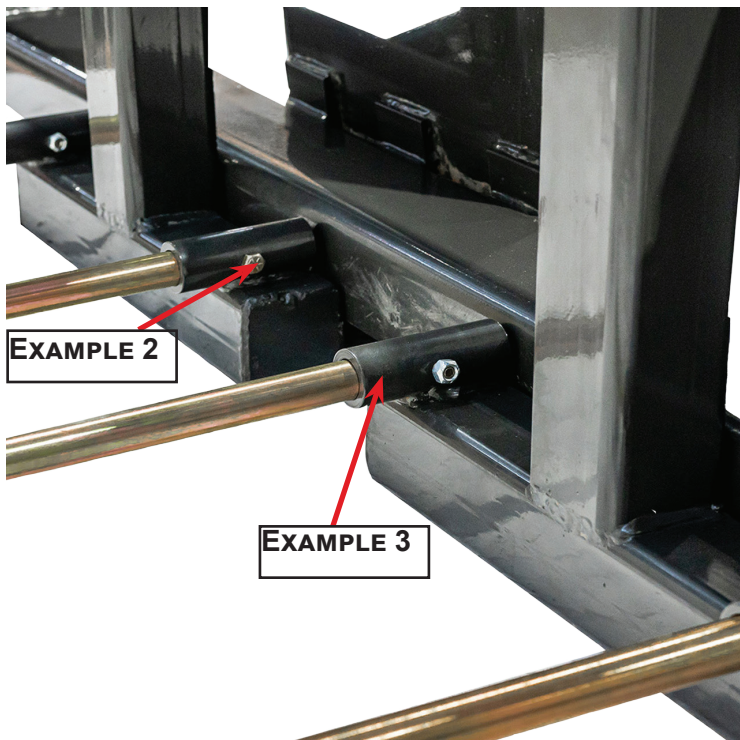

### **! WARNING** DOUBLE ADJUSTABLE HAY SPEAR ONLY

Make sure the adjustable posts are ALWAYS locked in place and greased. NEVER operate with one adjustable post in the center of the frame as it will fall off. This could create dangerous and hazardous conditions and cause injury or death!

# SECTION 6

## TROUBLESHOOTING

PROBLEM	POSSIBLE CAUSE	SOLUTION
Spears are bending or breaking.	<p>Spears are not fully inserted into the hay bale with the hay bale snug against the main frame.</p> <p>Using the hay spears for uses not intended such as prying objects from the ground.</p> <p>Too fast of travel may cause the hay bale to bounce on the spear(s).</p>	<p>Reposition bale so that the spears are fully inserted and the hay bale is snug against the main frame.</p> <p>Use hay spear(s) to carry hay bales only.</p> <p>To prevent bouncing, slow speed of travel.</p>
Machine is almost tipping over on its side or tipping forward.	<p>The machine does not have enough operating capacity or ballast on rear.</p> <p>Traveling forward while going down an incline with a slope greater than 10 degrees.</p> <p>Operating on too steep an incline.</p>	<p>Add ballast or use a different machine with higher operating capacity.</p> <p>Keep bale low to the ground &amp; do not drive sideways on an incline to help maintain stability of the machine.</p> <p>Only traverse inclines up and down and NOT while driving sideways.</p>
Bale is falling off end of spears	<p>Center core of hay bale is too loose or baling twine is broken.</p> <p>Traveling too fast.</p> <p>Spears are not fully inserted into the bale with bale against the main frame</p> <p>Traveling with spears level or tilted down at the front.</p> <p>Spears are bent down.</p>	<p>Make sure all spears are installed. DO NOT try to move broken bales with this attachment.</p> <p>To prevent bouncing, slow speed of travel.</p> <p>Reposition hay bale so that the spears are fully inserted and bale is resting against the hay bale frame.</p> <p>Use machine hydraulics or lift bale off the ground to accomplish 5-10 degrees if using a radial lift machine.</p> <p>Replace spears. Do not use spears once they have bent.</p>
Cannot lift hay bale	<p>Insufficient power to lift hay bale.</p> <p>Hydraulic leaks in host machine's hydraulic system.</p>	<p>Use a machine that is rated for more lift capacity.</p> <p>Investigate and repair leaks.</p>
Hay Spear moves on mounting plate.	<p>Locking pins are not engaged.</p> <p>Hay spear not properly attached to mounting plate.</p>	<p>Engage locking pins.</p> <p>Reattach hay spear to attachment mounting flange. Always verify attachment is properly attached before lifting hay bales.</p>

# SECTION 7

## PARTS INFORMATION

Factory OEM parts specifically designed for your implement are readily available.

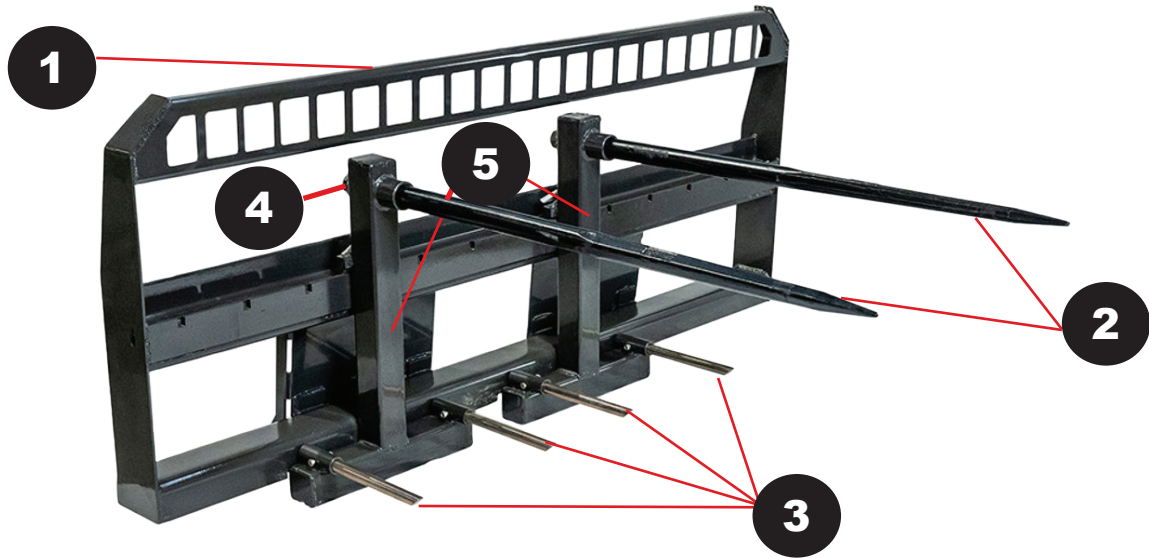

Ref	Part Description	QTY
1	Frame Weldment	1
2	Bale Spear 49" (CID9000) OR	VAR
	Bale Spear 39" (CID9001) OR	VAR
	Bale Spear 32" (CID9002)	VAR
3	Small Bottom Spear (SP-1.00X14.00 x.4375)	VAR
	3/8" 2" GR8 Bolt	VAR
	3/8" Locknut Holder	VAR
4	Fine Threaded M28x1.5" Nut (CID9005)	VAR
5	Hay Spear shown also includes:	
	SUB Assembly: DHABS-Spear Center_Weldment.	

# SECTION 8

## WARRANTY INFORMATION

### LIMITED WARRANTY

Construction Implements Depot, Inc. (CID) products are warranted to be free from defects in workmanship or materials for a period of 12 months from the initial sale.

#### WARRANTY EXCLUSIONS

This warranty does not cover normal wear items, including but not limited to: bearings, hoses, blade holders, ground engaging parts such as teeth, blades, cutting edges, pilot bits, auger teeth and broom bristles. This warranty does not cover maintenance, service or adjustments. This warranty does not cover damage due to improper application or installation, misuse, negligence, accidents or improper maintenance. Please note: Any modification or customization made to your attachment may void its warranty. This warranty is void if any components have been disassembled, i.e., pumps, gear boxes or motors or the attachment has been used without the case drain attached (if applicable). Be sure to follow all recommended Horsepower and GPM requirements as outlined in product specifications, in order to prevent the warranty from being void. This warranty is contingent upon the use of approved BRAND parts exclusively. Any use of non-approved parts may result in voiding the warranty. Please be advised that the warranty does not cover refurbished attachments. Specially modified attachments built by the manufacturer to meet your needs shall not be warranted by CID, Inc.

#### REPAIRS UNDER WARRANTY

**Any repairs, including welding, on attachments must be performed by certified repair technicians who have requested and obtained written approval from an authorized representative of CID before repairs begin.** If you are completing the repair, you must also have prior written approval to prevent the warranty from being voided.

#### WARRANTY STATEMENT

Our obligation under this Limited Warranty shall be solely limited to repairing or replacing any part (see non-covered items above) that, according to our judgment, show evidence of a defect in quality of workmanship or

## **8.0 WARRANTY INFORMATION CONT.**

materials for the stated 12 month warranty period. All defective parts must be routed directly to CID, Inc. with freight or delivery charges to be prepaid. This limited warranty shall not be interpreted to render CID, Inc. liable for any injury or damage to persons, businesses or property of any kind nor expenses or losses incurred for labor, supplies, substitute machinery rental or for any other reason. Repair or replacement parts are subject to the supply conditions at the time of repair or replacements, which may directly affect our ability to obtain material and/or replacement parts. CID, Inc. reserves the right to make improvements in design or changes in specifications at any time without incurring any obligations to owners of previously purchased products. No one but CID, Inc. is allowed to alter, modify or enlarge this warranty nor the exclusions, limitations and reservation at any time. CID, Inc. products are warranted to be free from defects in workmanship or materials for a period of 12 months from the initial sale.

*Purchaser and Manufacturer hereby (a) submit to the non-exclusive jurisdiction of the courts of competent jurisdiction in North Carolina and Davidson County in which this company resides for resolution of any dispute concerning this Limited Warranty or the rights or obligations of Purchaser and/or Manufacturer; (b) agree that any litigation in connection with this Limited Warranty shall be venued in North Carolina and Davidson County in which the company resides and (c) waive any objection they may have as to any such action or proceeding brought in such court that such court is an inconvenient forum. Nothing herein shall limit the right of Purchaser or Manufacturer (or the right of any permitted successor or assign of either) to bring proceedings against the other in the courts of any other jurisdiction wherein any assets of such other party may be located.*

---

## **8.1 WARRANTY RETURN AUTHORIZATION POLICY**

### **WARRANTY RETURN AUTHORIZATION POLICY:**

If repairs are required, a Return Material Authorization (RMA) number must be obtained for the defective part as well as proof of purchase. RMA and services are rendered by CID only. Any responsibility of shipping costs on any item returned for repair is at the discretion of CID, Inc.

All returned parts must have the following:

1. A legible RMA number written on the outside of the package.
2. Warranty Claim Form (online)
3. The defective part.

RMA numbers are only valid for 30 days from the date of issue. All shipped replacement parts will require a Parts Order (PO) number from the original CID, Inc dealer. Repairs not covered by the warranty, will be charged for parts and labor at the current pricing rate. Should you have any problems with your attachment, please follow the instructions listed on the following page.

## 8.2 WARRANTY PROCEDURE

### WARRANTY RETURN AUTHORIZATION PROCEDURE:

1. Call the Warranty Department at (336) 859-2002 EXT 215. You will need to provide the model and serial number of the defective item(s) (see Appendix for where to find this information), a description of the problem, and have photographs available.
2. Upon a warranted issue, visit [www.cidattachments.com](http://www.cidattachments.com), click on the warranty tab, and fill in the warranty information on the Warranty Claim Form.. CID, Inc will retain a Return Material Authorization (RMA) number of the defective part. If all the information above is completed CID, Inc will issue a RMA number via email..
3. Once you have an approved RMA number, a shipping label will be provided with CID's address and instructions for returning the defective part. **Appropriate RMA's/PO's will be invoiced and payment received while the evaluation process is being completed to prevent delays in your normal business operations. In the event the defective part(s) is un-warranted and repairs are not covered by the warranty, the customer will be invoiced for any additional parts and labor at the current pricing rate. If the part is deemed under warranty, a credit of the invoice will be issued.**
4. CID will ship a replacement part to the provided location or customer with a RMA identifier of some kind. **The customer is responsible for initial shipping charges until evaluation of the part has been completed.** If the part failure is covered by the warranty, the customer will be reimbursed for any paid shipping charges. In the event, the part is not covered by the warranty, the customer is responsible for return shipping.
5. Once the defective part is warranted by CID, the customer will be issued a credit and the PO number will no longer be active.
6. In the event CID decides that the attachment needs to be returned to them for repair, CID will make arrangements for pickup and return. Repairs will be performed by CID qualified technicians. Non-warranted issues will be discussed, and repairs will be performed upon the owner's agreement and receipt of payment for parts and labor.

# SECTION 9

## **SAFETY ACKNOWLEDGMENT & MAINTENANCE LOG**

**ATTENTION ALL OPERATORS:** Print your name, sign and date in the boxes below to acknowledge that you have read and fully understand the safety instructions presented in this manual, and have been trained on how to safely operate this attachment.

<b>OPERATOR NAME</b>	<b>SIGNATURE</b>	<b>DATE</b>

Document all routine maintenance and repair services performed on this attachment.

<b>DESCRIPTION OF MAINTENANCE/REPAIR</b>	<b>SERVICED BY:</b>	<b>DATE:</b>





**TRUSTED ATTACHMENTS**



EST.

**CID**

2003

**INDUSTRIAL QUALITY**

**CONSTRUCTION IMPLEMENT DEPOT  
DENTON-USA, LLC  
1248 N. MAIN ST  
DENTON, NC 27239**

**[www.CIDATTACHMENTS.COM](http://www.CIDATTACHMENTS.COM)**



CIDHS-MANU-V2M1224