

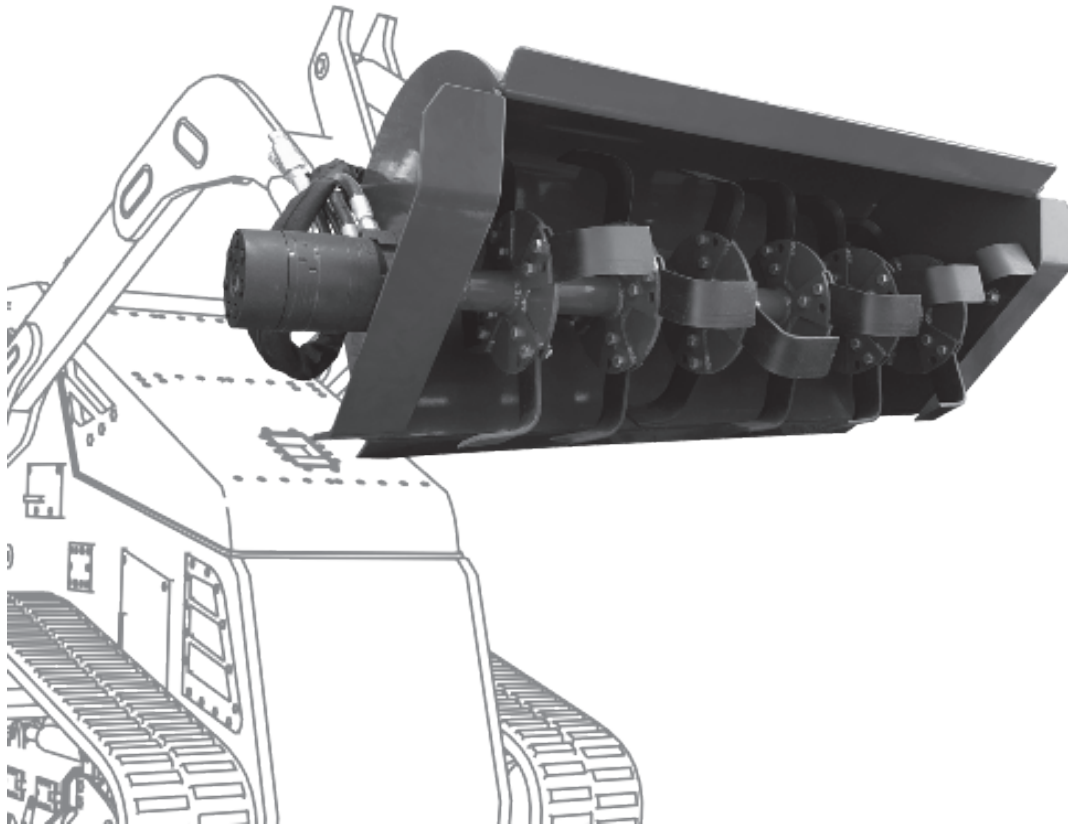

ROTARY TILLERS

OWNER'S MANUAL



SEP
2024

OPERATING INSTRUCTIONS | SAFETY RULES | MAINTENANCE PROCEDURES

REGISTER YOUR PRODUCT

CID

336-859-2002

MODEL

WEIGHT

PART

HP RANGE

SERIAL

HYDRAULIC PRESSURE

HYDRAULIC FLOW

WWW.CIDATTACHMENTS.COM

Please see the inside of the back cover for instructions of where to find your model and serial number.

WARNING

To prevent personal injury or even death, be sure you read and understand all the instructions in this manual and other related OEM equipment manuals! This attachment if not used and maintained properly, can be dangerous to users unfamiliar with its operation. Do not allow operating, maintaining, adjusting, or cleaning of this attachment until the user has read this manual and has developed a thorough understanding of the safety precautions and functions of the unit. This attachment is designed for the purpose specified. DO NOT modify or use this attachment for any application other than that for which it was designed. Attachments maintained or operated improperly or by untrained personnel can be dangerous, exposing the user and/or bystanders to possible serious injury or death.

Purchase Date:

Dealer Name:

Address:

Phone Number:

WELCOME

Thank you for choosing CID. This attachment has been designed and manufactured to meet the needs of discerning users. We are committed to providing you with a heavy duty product that will provide years of satisfaction and safe operation.

This manual will provide instructions on how to safely operate and maintain this attachment. All users must read and understand this manual before operating this machine. Upon reading this manual, all users should sign the “Safety Acknowledgment Form” at the end of this manual.

Please record your model and dealer information on the inside front cover. You will be asked to provide this information when ordering parts or requesting service. If you need more information on this product, contact your local dealer or visit www.cidattachments.com.

*Sincerely,
The CID Team*



TABLE OF CONTENTS

INTRODUCTION	3
WARRANTY DISCLAIMERS	5
SECTION 2 SAFETY INFORMATION	
2.1 Safety Terms.....	6
2.2 Safety Symbols.....	7-8
2.3 Safety Decals.....	9-10
2.4 Skid Steer Loader Requirements.....	11
2.5 Personal Protective Equipment Requirements.....	11
2.6 General Safety Instructions.....	12
2.7 Federal Laws & Regulations.....	13
SECTION 3 OPERATING PROCEDURES	
3.0 Unpacking Your Rotary Tiller.....	14
3.1 How to Connect Attachment.....	14-15
3.2 How to Disconnect Attachment.....	16
3.3 Controls.....	16
3.4 First Time Use.....	17
3.5 Tiller Operations.....	18-19
3.6 Tiller Safety.....	19
SECTION 4 MAINTENANCE PROCEDURES	
4.0 Maintenance Overview.....	20-21
4.1 Maintenance Schedule.....	21
4.2 Maintenance Log Instructions.....	22
4.3 Storage Tips.....	22
4.4 Torque Specification Table and Instructions.....	23
4.5 Torque Equipment Requirements.....	23
4.4 Tine Removal and Installation.....	24
SECTION 5 TROUBLESHOOTING	
5.0 Troubleshooting Chart.....	25
SECTION 6 SPECIFICATIONS	
6.0 Specification Chart.....	26
SECTION 7 PARTS INFORMATION	
7.0 Parts Information Form.....	27
7.1 Parts Diagram.....	28-29
SECTION 8 WARRANTY INFORMATION	
8.0 Warranty Statement.....	30-31
8.1 Warranty Return Authorization.....	31
8.2 Warranty Procedure.....	32
SECTION 9 SAFETY ACKNOWLEDGMENT FORM	33
SECTION 10 MAINTENANCE LOGS	34
APPENDIX A HOW TO FIND YOUR SERIAL NUMBER	35

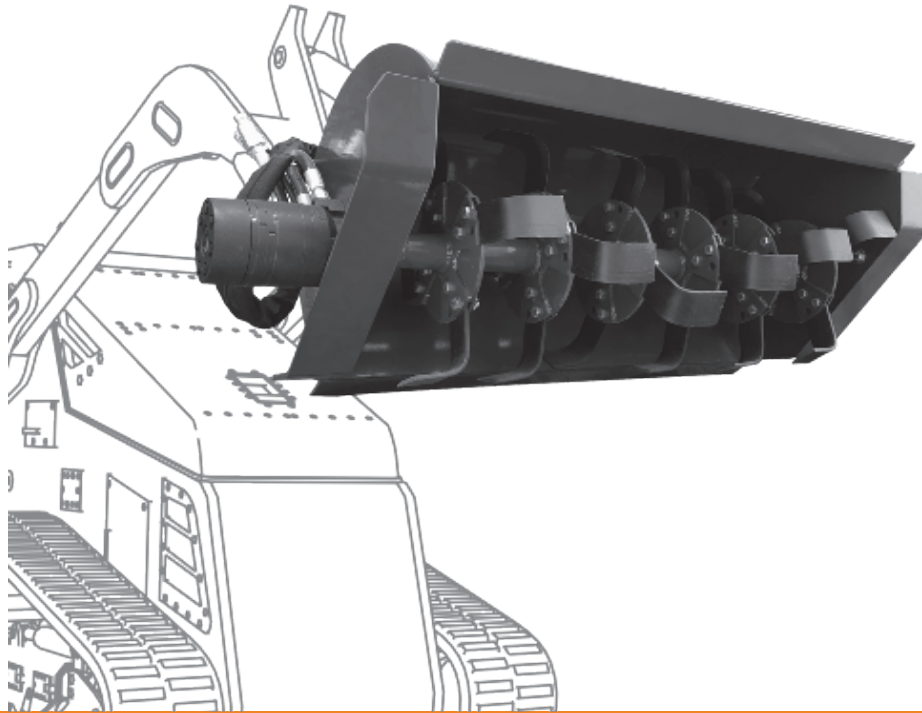

IMPORTANT WARRANTY DISCLAIMERS

ATTENTION: If your attachment has control valves, cylinders, gearboxes, or motors and they are opened or disassembled, the **WARRANTY for that item WILL IMMEDIATELY BE VOIDED!**

GEAR OIL STATEMENT: If applicable in your attachment, check gear oil before each use: **We recommend using 85-140 grade gear oil**, for use with all our gear boxes, and bearing housings which is separate from the hydraulic fluid used to move your attachment or machine.

(Exception: gear oil used in mulchers is Shell Omala S2 GX 150!)

HYDRAULIC FLUID STATEMENT: Check your machine's hydraulic level and add hydraulic fluid if necessary before each use. Inspect for leaks, and repair if necessary. **Always use your machine's manufacturer recommended hydraulic fluid in your machine!** Fluid must be clean and debris free. If damage occurs from debris in hydraulic fluid flowing from your machine to our attachment it will VOID the warranty on any cylinders, motors, couplers, manifolds &/or valves (relief, lock, selector, check and flow control) downline from that flow.

SECTION 2

SAFETY INFORMATION

The following terms may be used interchangeably throughout this manual.

Term	Alternate Terms Used
Rotary Tiller	implement, attachment, tiller, rotary tiller
Machine	skid steer loader, skid steer tractor, loader, prime mover, host machine, tractor
Operator	user, personnel

The **Rotary Tiller Attachment** is designed and manufactured with safety in mind. However, improper use and operator error can result in death or serious injury. It is important that you read and fully understand the safety instructions and operating procedures presented in this manual before operating this attachment. Accident prevention is a combination of good judgment, common sense, awareness and proper training!



BEFORE YOU OPERATE THIS ROTARY TILLER:

KNOW how to safely operate your machine.

READ and UNDERSTAND the safety instructions and operating procedures contained in this manual.

ACKNOWLEDGE your understanding of all safety instructions presented in this manual by signing the “Safety Acknowledgment Form” at the end of this manual.

Although every effort has been made to ensure a safe product, every possible circumstance that could pose a potential hazard cannot be anticipated. The warnings presented in this manual and on this product, are therefore not all-inclusive.

In addition to the safety messages presented in this section, you must also read and understand the safety messages presented in the other sections of this manual.

This manual and the decals on this machine use safety symbols, hazard labels, pictograms and color coded signal words to alert you to potential hazards that may cause severe injury or death if a safety instruction is ignored.



SAFETY ALERT SYMBOL - This symbol is used to alert you to potential personal injury hazards. Obey all safety messages that follow this symbol to avoid possible injury or death.

HAZARD CLASSIFICATIONS

Hazards are identified by the “Safety Alert Symbol” and followed by the signal word “DANGER”, “WARNING”, or “CAUTION”.

DANGER

Indicates an imminently hazardous situation which, if not avoided, will result in death or serious injury.

This signal word is limited to the most extreme situations.

WARNING

Indicates a potentially hazardous situation which, if not avoided, could result in death or serious injury.

CAUTION

Indicates a potentially hazardous situation which, if not avoided, may result in minor or moderate injury.

NOTICE

Indicates a situation which may cause damage to equipment or property.







Messages are not related to personal injury.

Safety Instructions

Indicates specific safety-related instructions or procedures.

2.2 SAFETY SYMBOLS

Pictograms are graphic symbols meant to alert you of a potential hazard. Read and understand the hazard description for each of these symbols.

Pictogram	Description
	PINCH HAZARD: Keep clear of machine and attachment to prevent death or serious injury from pinching of moving parts.
	OPERATING MANUAL: Operators must read and understand the safety instructions in the operating manual to prevent death or serious injury.
	EYE PROTECTION & CARDBOARD: Operators and Maintenance personnel must wear proper eye protection and use cardboard or wood to investigate hydraulic leaks to prevent death or serious injury from being injected with high pressure hydraulic fluid.
	HIGH PRESSURE FLUID INJECTION HAZARD: Operators and Maintenance personnel must not place fingers or hands directly over a hydraulic leak to prevent death or serious injury from being injected with high pressure hydraulic fluid.
	NO BYSTANDERS: DO NOT operate this attachment near bystanders. Bystanders must stay back at least 100 feet from the attachment to prevent death or injury from flying objects.
	CRUSH HAZARD: DO NOT place any part of the body under the attachment or machine arms to prevent death or serious injury from being crushed .

CONTACT YOUR LOCAL DEALER TO ORDER REPLACEMENT DECALS

2.3 SAFETY DECALS

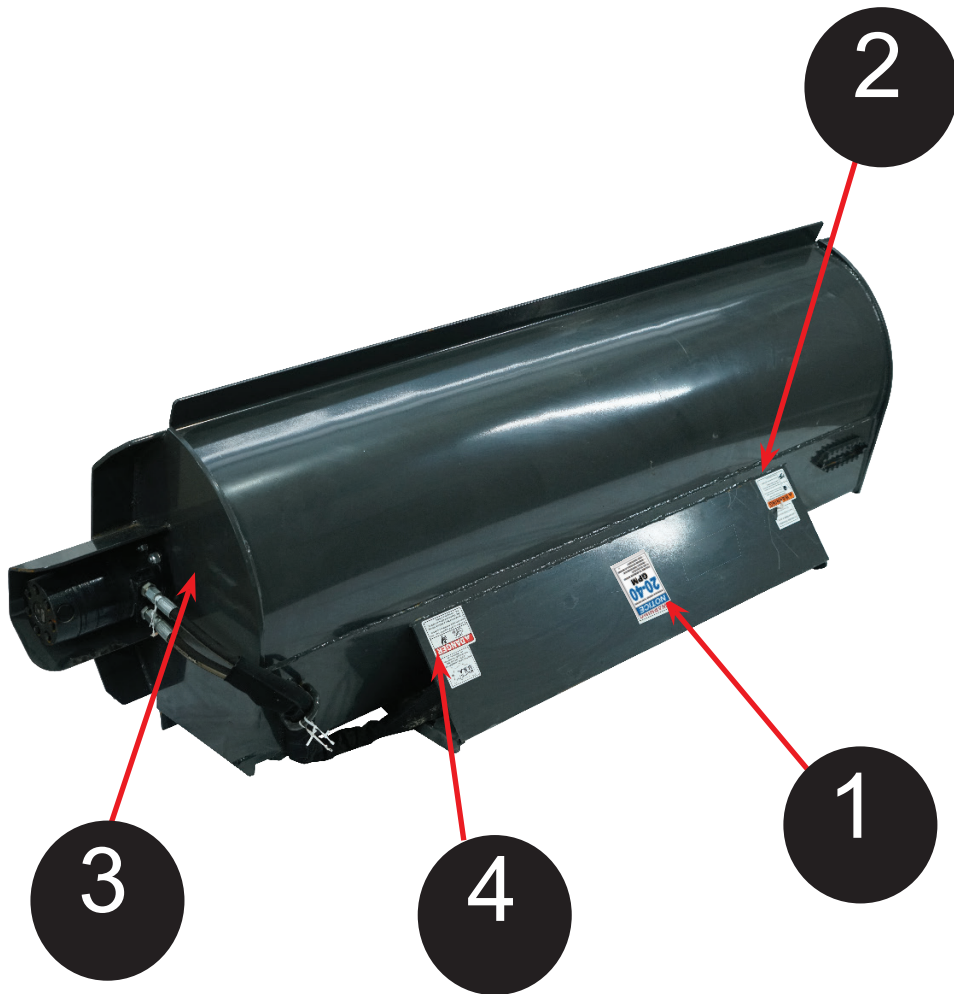

Safety warning decals are located on this attachment near immediate areas of potential hazards. Operators must learn the meaning of each decal and know where to find the decal on the attachment.



2.3 SAFETY DECAL CHART

The safety decals affixed to this attachment are to keep you safe. DO NOT ignore these decals.

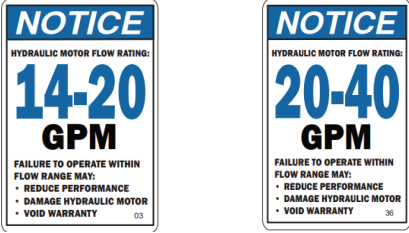
Read and understand each decal's safety message. Follow these Safety Decal Instructions:

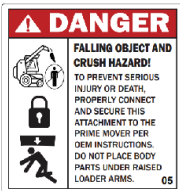
REF	DESCRIPTION	LABEL	QTY
1	WARNING DO NOT EXCEED GPM LABEL		1
2	HIGH PRESSURE FLUID HAZARD WARNING		1
3	PINCH POINT HAZARD CAUTION LABEL		2
4	FALLING HAZARD DANGER LABEL		1

**WHEN ORDERING, CHOOSE THE PROPER DECAL FOR YOUR MODEL*

- ⚠️ Decals must be kept clean and legible at all times.
- ⚠️ Operators must inspect the attachment for safety decals.
- ⚠️ Replace missing, worn or damaged decals immediately.
- ⚠️ When using a hot pressure washer to clean this attachment make sure water jet is not too close to the decal as this may cause the decal to peel.
- ⚠️ When replacing parts, be sure safety decals are in place prior to using the attachment.
- ⚠️ Make sure metal surface is dry and free of dirt and grease before affixing decals to this attachment.

2.4 SKID STEER LOADER REQUIREMENTS

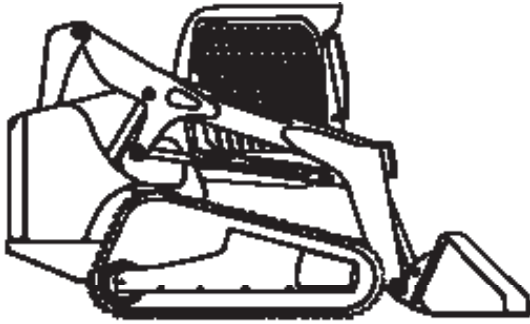

Tracked

VS.



Wheeled

A Tracked Skid Steer or Compact Track Loader (CTL) will provide superior stability in this application.

Follow the operating instructions in your Skid Steer operator's manual.

Machines must have impact resistant windshields and cab side windows.

THE ROTARY TILLER Attachment should only be used on Machines that meet the following requirements:

MACHINE	MINI	Low FLOW	HIGH FLOW
GPM	Consult Manufacturer	14-20 GPM	20-40 GPM

2.5 PERSONAL PROTECTIVE EQUIPMENT (PPE)

All operators should wear hearing protection, safety glasses, hand protection and dust mask while operating this attachment.



2.6 GENERAL SAFETY INSTRUCTIONS



MAKE SURE YOU FOLLOW THE GENERAL SAFETY INSTRUCTIONS THAT RELATE TO THE OVERALL OPERATION AND MAINTENANCE OF THIS ATTACHMENT. IT IS IMPORTANT THAT YOU READ AND UNDERSTAND EACH OF THESE MESSAGES TO PREVENT SERIOUS INJURY OR DEATH.

- ! NEVER** use drugs or alcoholic beverages while operating or servicing this attachment.
- ! DO NOT** allow children to play on or around this attachment at any time. Store this attachment in an area not frequented by children.
- ! ALWAYS** operate this attachment during daylight or well-lit areas.
- ! ALWAYS** wear the proper personal protection equipment while operating or servicing this attachment. **NEVER** operate or service this attachment with bare feet, sandals, or other light footwear.
- ! We recommend** using a high strength clear protective door panel when using with this attachment.
- ! ALWAYS** wear work gloves when handling this attachment to protect your hands.
- ! To prevent** the machine and attachment from rolling forward, stop the engine and set the parking brake when exiting the machine.
- ! ALWAYS** use eye protection while operating or servicing this attachment.
- ! Inspect** attachment for loose or missing hardware prior to using this machine.
- ! ALWAYS** watch for overhead power lines.
- ! DO NOT** operate this attachment during lightning or severe weather conditions.
- ! DO NOT** place any part of your body under this attachment.
- ! DO NOT** allow riders on the machine or on this attachment.
- ! NEVER** operate this attachment when bystanders are within 100 feet of your work area. Falling material could cause serious injury or death.
- ! ALWAYS** call 811, the “Digger’s Hotline” before digging to identify underground utilities to avoid an accident that could result in Death or Serious Injury to the operator.
- ! NEVER** position your body or limbs under an unsupported attachment.
- ! DO NOT** speed! Speed Kills! Keep your driving speed between 2 and 5 mph.
- ! DO NOT** allow this attachment to contact buildings, utilities, large rocks or tree stumps or you may lose control of the machine.

2.7 FEDERAL LAWS & REGULATIONS

IMPORTANT FEDERAL LAWS AND REGULATIONS CONCERNING EMPLOYERS, EMPLOYEES, AND OPERATORS

This section is intended to explain in broad terms the concept and effect of the following federal laws and regulations. It is not intended as a legal interpretation of the laws and should not be considered as such.

U.S. PUBLIC LAW 91-596 (The Williams-Steiger Occupational Safety and Health Act of 1970) OSHA

This Act Seeks:

“ ... to assure so far as possible every working man and woman in the nation safe and healthful working conditions and to preserve our human resources...”

Sec. S(a) Each Employer –

DUTIES

(1) shall furnish to each of its employees employment and a place of employment which are free from recognized hazards that are causing or are likely to cause death or serious physical harm to its employees.

(2) shall comply with occupational safety and health standards promulgated under this Act.

(b) Each employee shall comply with occupational safety and health standards and all rules, regulations, and orders issued pursuant to this Act which are applicable to his or her own actions and conduct.

OSHA Regulations

Current OSHA regulations state in part: “At the time of initial assignment and at least annually thereafter, the employer shall instruct every employee in the safe operation and servicing of all equipment with which the employee is, or will be involved.” These will include (but are not limited to) instructions to:

Keep all guards in place when the machine is in operation;

Permit no riders on equipment;

Stop engine, disconnect the power source, and wait for all machine movement to stop before servicing, adjusting, cleaning, or unclogging the equipment, except where the machine must be running to be properly serviced or maintained, in which case the employer shall instruct employees as to all steps and procedures which are necessary to safely service or maintain equipment.

Make sure no one is within 300 feet of machinery before starting the engine, engaging power, or operating the machine.

EMPLOYEE MACHINE OPERATING INSTRUCTIONS:

1. Securely fasten your seat belt if the machine has a ROPS.
2. Where possible, avoid operating the machine near ditches, embankments, and holes.
3. Reduce speed when turning, crossing slopes, and on rough, slick, or muddy surfaces.
4. Stay off slopes too steep for safe operation.
5. Watch where you are going, especially at row ends, on roads, and around trees.
6. Do not permit others to ride.
7. Operate the machine smoothly - no jerky turns, starts, or stops.
8. Hitch only to the drawbar and hitch points recommended by machine manufacturers.
9. When machine is stopped, set brakes securely and use park lock if available.

Child Labor Under 16 Years Old

Some regulations specify that no one under the age of 16 may operate power machinery. It is your responsibility to know what these regulations are in your own area or situation. (Refer to U.S. Dept. of Labor, Employment Standard Administration, Wage & Home Division, Child Labor Bulletin # 102).

3.0 UNPACKING YOUR ROTARY TILLER

SECTION 3

OPERATING PROCEDURES

Your attachment arrives from the factory strapped to a wood pallet and requires no final assembly. Use a steel band cutting tool to remove the steel straps.

! CAUTION

Shipping straps are under great tension, and could lash out uncontrollably when cut causing injuries to your body or bystanders. Keep bystanders away and wear safety glasses and gloves while removing the steel straps.

3.1 HOW TO CONNECT ATTACHMENT

GENERAL ATTACHMENT METHOD

Refer to your machine operator's manual for specific instructions on how to connect and disconnect your attachment.

This attachment method refers specifically to skid steers. For all other attachment instructions, refer to the Original Equipment Manufacturer (OEM) for instructions.

1. Ensure the hydraulic lines are clear from the front side of the attachment bracket and that the levers on the skid steer Quick Attach Coupler are in the unlocked position.
2. Tilt the skid steer loader Quick Attach Coupler slightly down and drive forward to the rear of the rotary tiller until the top edge of the Quick Attach Coupler hooks under the lip of the attachment bracket. See figure 3.1a below.
3. Slightly tilt the skid steer Quick Attach Coupler upward until the rotary tiller attachment bracket is flat against the skid steer Quick Attach Coupler. See figure 3.1a below.



FIGURE 3.1A - QUICK ATTACH COUPLER LOCKED TO ATTACHMENT

3.1 HOW TO CONNECT ATTACHMENT

4. Activate your skid steer's lever lock switch to lock the pins into the attachment bracket. If your skid steer does not have this switch, manually lock the pins as shown in Figure 3.1b below.

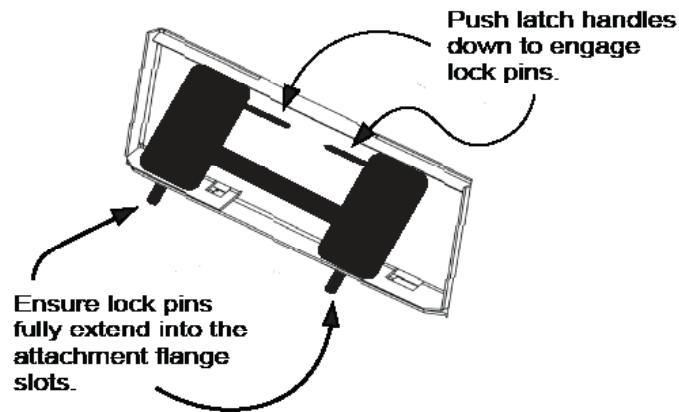

FIGURE 3.1B QUICK ATTACH COUPLER LOCKED TO ATTACHMENT BRACKET

! WARNING

To avoid serious injury or death, ensure locking pins fully extend through the slots on the attachment bracket and that levers are down in the locked position to prevent attachment from detaching from skid steer.

NOTICE

To keep contaminants from entering the hydraulic system, use a clean cloth to wipe away dirt and grease from the hydraulic couplers.

5. Connect the attachment hydraulic hoses to the auxiliary supply couplers located on your skid steer loader lift arm.

NOTICE

Check that hydraulic hoses are locked into the machine couplers before starting the attachment.

NOTICE

If during your initial startup, you realize the rotary tiller operates in the opposite direction that you prefer, you can change positions of the quick disconnect couplers on the attachment hoses to remedy your problem.

3.2 HOW TO DISCONNECT ATTACHMENT

DISCONNECTING ATTACHMENT

1. Turn off auxiliary hydraulic circuit; relieve hydraulic pressure.
2. Park machine on a flat and level surface then lower rotary tiller to the ground.
3. Set parking brake and disengage lock pins using the lock lever switch (if installed).
4. Turn off machine engine.
5. Disconnect hydraulic hoses.
6. Pull latch handles to disengage lock pins.
7. Re-enter cab and start machine engine.
8. Tilt mounting coupler forward until Quick Attach Coupler is free from mounting bracket.
9. Drive machine backward to clear attachment.

3.3 CONTROLS



*Please refer to our “Hydraulic Fluid and Oil Statement” on Page 5
for gear oil or hydraulic fluid instructions.*



ATTACHMENT CONTROLS

Your rotary tiller is designed to run off the host machine’s auxiliary hydraulic system, and is activated and deactivated by a control in the operator’s cab. The height and tilt functions of your attachment are operated with the control handles or pedals in the cab. Consult your machine operator’s manual for instructions regarding these functions.

HYDRAULIC FLOW REQUIREMENTS

When operating the attachment, set the machine engine RPM to a speed that will produce the required flow. Your machine dealer can measure the flow available on your machine and recommend a throttle setting that is compatible with this attachment.

NOTICE

DO NOT exceed the designed flow rate (GPM) of your rotary tiller. Check the specifications table for your specific model’s max GPM.

NOTICE

Before operating your attachment, check the hydraulic fluid level in the machine and add manufacturer recommended fluid if necessary.

Verify that hydraulic hoses are securely locked to the machine's hydraulic couplers before starting the attachment.

1. Set machine engine RPM to just above idle and flip the auxiliary hydraulic switch to the ON position.
2. Raise the attachment 6 inches off the ground.
3. With the machine engine RPM just above idle, activate the machine's auxiliary hydraulic system.
4. Allow the tiller to run for 30 seconds to purge air from the system, then turn off hydraulic flow.
5. Lower the attachment to the ground, set parking brake, then shut off machine engine and exit the cab.
6. Check the hydraulic fluid level in the machine, add manufacturer recommended fluid if necessary.

WARNING

To avoid serious injury by hydraulic fluid injection into your skin, never use your hand or other body parts to locate a hydraulic leak. Detect leaks with a piece of wood or cardboard.

7. Inspect the rotary tiller's hydraulic lines for noticeable leaks. Fix before continuing.



3.5 TILLER OPERATIONS

WARNING

Never operate this attachment in an enclosed work area. Exhaust fumes could result in serious injury or death. This attachment should be used in an open air environment.

CAUTION

Enter and Exit the host machine on the right side when the tiller attachment is connected.
Hydraulic hoses can be a trip hazard.

STARTING THE TILLER

1. With the tiller properly connected to the host machine, engage the tiller with the machine's engine set to a low RPM.
2. Slowly increase the engine's RPM to the desired tiller speed.

NOTICE

If the tiller creates a vibration when ramping up to speed, turn off machine's auxiliary hydraulic system and shut down the engine. Investigate the cause of the vibration to avoid damage to the tiller. See Troubleshooting Chart.

STOPPING THE TILLER

1. Slightly raise tiller from the soil.
2. Reduce engine RPM.
3. Turn off auxiliary hydraulics when tiller rotation slows down.

BEFORE TILLING

1. Inspect the work area and make sure it is free of any utilities, rocks, fence posts, barbed wire, rope, twine, and any other objects that could damage the machine or tiller.

NOTICE

Cutting tree roots with this tiller could result in damage to the tiller. In the presence of roots, raise the attachment to avoid roots.

3.5 TILLER OPERATIONS CONT.

TILLING TIPS

1. Inspect the work area and make sure it is free of any utilities, rocks, fence posts, or any other objects that could be damaged.
2. Keep all bystanders away when operating this attachment to prevent accidents.
3. Operate at a safe speed that will allow you to watch the area ahead of the tiller and behind the machine.
4. Wait until the tiller rotation is at operating speed before lowering into the ground.
5. When tilling dense, heavy, or hard soil, make multiple passes with the tiller until the desired depth is achieved.
6. Never use the tiller to push, pull, or lift objects.
7. The tiller only has one side of the tines sharpened, so should always rotate *AWAY* from the operator when tilling. Tilling should only occur while driving the machine backward. See *examples 3.5a & 3.5b*.
8. To bury vegetation, the tiller tines should rotate the opposite of the machine tires/tracks rotation.

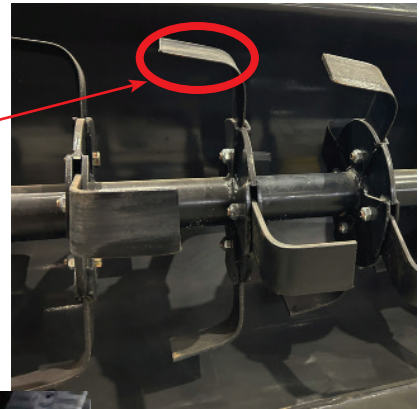

FIGURE 3.5A SHARP TILLER TINE



FIGURE 3.5B CORRECT TILLER TINE ROTATION & MACHINE DIRECTION.

3.6 TILLER SAFETY

⚠️ WARNING

To avoid a roll over accident which may result in serious injury or death, **DO NOT** operate the machine and attachment on uneven terrain or sloped surface with the attachment raised more than 6" off the ground.

⚠️ CAUTION

To avoid injury from flying debris or rocks being thrown back at the operator, never operate this attachment with bystanders nearby or machine arms raised at or above eye level of the operator.

4.0 MAINTENANCE OVERVIEW

SECTION 4

MAINTENANCE PROCEDURES

The maintenance procedures described in this manual should only be carried out by qualified mechanics who have been trained to repair this attachment.

Some procedures require special tools and skills to complete. **DO NOT** attempt to repair or perform service work on this attachment unless you have the skills and tools to do so. Contact your local dealer for maintenance and repair services.

WELDING REPAIRS

Welding on attachments must be performed by certified welders who have requested and obtained written approval from an authorized representative of the manufacturer before welding begins.

All authorized welding repairs must be performed by qualified welders in accordance to the American Welding Society (AWS) standards. Welding procedures performed by unqualified welders may deem this attachment unsafe to operate and **VOID THE WARRANTY!**

WARNING





PARTS

Only use genuine Original Equipment Manufacturer (OEM) replacement parts. We will not be liable for any damages or injuries caused by the use of after market parts on this attachment.



NOTICE

Improper maintenance or modifications to the design or performance of this attachment will void the warranty. **ONLY** use genuine OEM replacement parts on this attachment.

Obey the following safety instructions when servicing or repairing this attachment.

-  **Wear proper Personal Protective Equipment (PPE) while working on this attachment, which may include safety glasses, hard hats, steel toe boots, gloves, etc.**
-  **If servicing is performed while the rotary tiller is attached to the machine, turn engine off, set parking brake and chock wheels to prevent machine from moving.**
-  **Ensure all jack stands, lifts and hoists are in good working condition and have the rated load capacity to support the load.**
-  **Wear a welding helmet when welding to protect your eyes, face and neck from flash burn, ultra-violet radiation and heat.**

4.0 MAINTENANCE OVERVIEW CONT.

-  Only perform service work in a well-lit area.
-  Allow the attachment to cool down before servicing this machine.
-  NEVER work under an unsupported rotary tiller.

4.1 MAINTENANCE SCHEDULE

This **ROTARY TILLER** attachment will provide years of dependable service if routine maintenance procedures are performed. The maintenance tasks listed below are based on normal operating conditions. More frequent maintenance may be necessary with intense use or when operating in adverse environmental conditions.

MAINTENANCE TASK	BEFORE EACH Use	WEEKLY	YEARLY
<p>Check host machine's hydraulic fluid level. Add manufacturer recommended fluid as necessary.</p> <p><i>Please refer to our "Hydraulic Fluid and Oil Statement" on Page 5 for gear oil or hydraulic fluid instructions.</i></p>	X		
<p>Check that all fasteners (nuts, bolts, washers, pins, keepers) are in place. Tighten as necessary before each use.</p>	X		
<p>Inspect and replace any worn, torn, or missing safety decals.</p>	X		
<p>Inspect hydraulic hoses and connectors for damage or leakage. Repair or replace hydraulic items as necessary.</p>	X		
<p>Lubricate all bearings using #2 Lithium grease.</p>	X		
<p>Wash rotary tiller.</p>		X	
<p>Check the condition of the tines by raising the tiller attachment off the ground to a 90 degree angle for inspection*. Replace or repair tines as needed</p> <p><i>*Make sure to apply a lift arm lock.</i></p>		X	
<p>Check attachment for major scratches & dings. Sand and repaint these areas to prevent rust damage. *Use formulated for farm equipment which can be found at your local hardware store.</p>			X

4.2 MAINTENANCE LOG INSTRUCTIONS

Document all maintenance and service activities performed on this attachment using the maintenance log sheets included at the end of this manual.



MAINTENANCE LOG

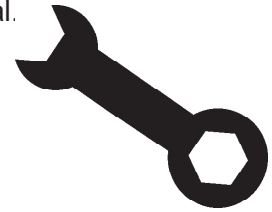

10. MAINTENANCE

MAINTENANCE LOG

DESCRIPTION OF MAINTENANCE/REPAIR	SERVICED BY:	DATE:
<i>Replace Filter Blades</i>	<i>Joe Smith</i>	01/24/24
<i>Inspect Hydraulic Plumbing</i>	<i>Joe Smith</i>	02/25/24
<i>Change Oil in Bearing Housing</i>	<i>Joe Smith</i>	04/24/24

4.3 STORAGE TIPS

To get years of quality use out of your attachment, follow these tips when storing your attachment for the season:

	<p>Ensure attachment is free of debris, dirt and grease.</p>
	<p>Store your attachment in a dry shed or garage.</p>
	<p>When storing your attachment for the season, cover with a weather proof tarp to protect it from the elements.</p>

4.4 TORQUE SPECIFICATION TABLE AND INSTRUCTIONS

BOLT TORQUE INSTRUCTIONS

1. Apply and maintain proper torque on all bolts.
 2. Torque values are based on lubricated values. **Do not grease or oil bolts.**
 3. Wipe bolts clean and use Loctite 635 or equivalent before tightening bolts. May need curing activator.
 4. Use a torque wrench to assure the proper amount of torque is being applied to the bolt.
- 5. MUST CURE 72 HOURS BEFORE USE TO PREVENT LOOSENING OF BOLTS.**

TORQUE VALUES

SAE GRADE 8

	DRY lb.-ft.	LUBRICATED lb.-ft.
1/4"	12	9
5/16"	24	18
3/8"	45	35
1/2"	110	80
3/4"	380	280
7/8"	600	450
1"	910	680
1 1/4"	1820	1360
1 1/2"	3162	2688

4.5 TORQUE EQUIPMENT REQUIREMENTS

TOOLS & EQUIPMENT REQUIREMENTS

To complete the maintenance procedures described in this section, you may need the following tools:

- 1/2 inch drive breaker bar
- 3/4 inch impact socket
- 1/2 inch impact socket
- Tapping Hammer
- 1/2 inch drive torque wrench
- Nylon pry bar set
- Safety stands
- **Loctite 635 or Equivalent-MUST CURE 72 HRS**
- Lifting device (overhead crane hoist, forklift)



NOTE:

When removing bolts with Loctite, it will be necessary to apply localized heat of at least 250 degrees Celsius or to 482 degrees Fahrenheit to loosen bolts.

LOCTITE 635 TECHNICAL SPECIFICATIONS FOR BONDING, CURING, REMOVAL AND INSTALLATION CAN BE FOUND HERE:

<https://next.henkel-adhesives.com/>

4.6 TINE REMOVAL AND INSTALLATION

SERVICING YOUR TILLER TINES

1. Using the machine controls, position the attachment on the ground or other safe and stable spot to access the tine hardware on the rotator shaft.
2. Power off machine and make sure your lift arms are in the locked position to prevent serious injury or death.
3. Remove the two sets of bolts/nuts, securing the tine to the rotator shaft.
4. Inspect the hardware.
5. If the bolt is loose in the rotator shaft collar and/or shows signs of wear, replace the old hardware with new hardware that is manufacturer recommended using identical bolt diameter and length and torque to the specifications listed.
6. If a tine is damaged, remove the damaged tine, attach new tine and torque the bolts to the proper specifications found in this manual.

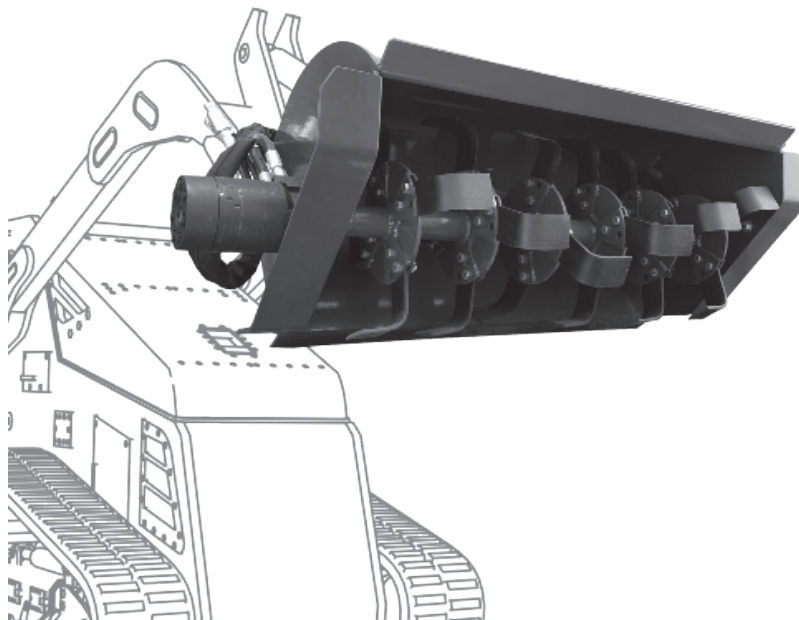
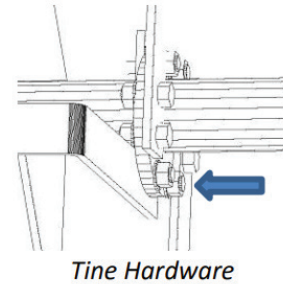

SECTION 5

TROUBLESHOOTING

PROBLEM	POSSIBLE CAUSE	SOLUTION
Tiller bogs down.	<ol style="list-style-type: none">1. Frame is not properly leveled & material is balling under deck.2. Broken or bent tines.3. Ground speed too fast.4. Tiller speed too slow.	<ol style="list-style-type: none">1. Refer to leveling instructions.2. Remove and replace broken or bent tines.3. Reduce speed.4. Raise engine RPM or check for low fluid flow.
Vibration felt when running tiller.	<ol style="list-style-type: none">1. Missing, loose, damaged tiller tines.2. Tine mount damage.	<ol style="list-style-type: none">1. Replace missing or damaged tines.2. Replace drive shaft.
Tines do not spin when flow is activated.	<ol style="list-style-type: none">1. No hydraulic fluid flow.2. Dual motor models - hoses at one or the other motors is incorrectly connected.3. Motor output shafts failed.4. Blade spline carrier bushing failure.	<ol style="list-style-type: none">1. Check quick disconnects and auxiliary hydraulic circuit.2. Switch motor hoses on the motor.3. Call dealer for further recommendations.4. Install new blade carrier.

DANGER

ONLY service the attachment on stable, even terrain. NEVER park on sloped terrain to avoid being struck and killed or seriously injured by the unexpected rolling or movement of the machine.

SECTION 6

SPECIFICATIONS

	72" LOW FLOW	72" HIGH FLOW	84" HIGH FLOW
Till Width	72"	72"	84"
Overall Width	87"	93"	105"
Overall Height	27"	27"	27"
Overall Length	30"	30"	30"
Till Depth Max	6"	6"	6"
Number of Tines	36	36	44
Hydraulic Flow Requirements	14-20 GPM	20-40 GPM	20-40 GPM
Max Pressure	3000 PSI	3000 PSI	3000 PSI
Attachment Weight	794 lbs	856 lbs	949 lbs

SECTION 7

PARTS INFORMATION

Factory OEM parts specifically designed for your attachment are readily available.

For hassle free service and to ensure you receive the correct parts for your attachment, please provide your dealer with the following information:

Model Number	
Serial Number	
GPM Requirements	
Date of Owners Manual (Bottom Left Corner of Cover Page)	
Parts Diagram Page Number	
Part Description	
Reference #	
Quantity Desired	
Ship To Information	
Bill To / Payment Information	

7.1 PARTS DIAGRAM

LOW FLOW ROTARY TILLER



HIGH FLOW ROTARY TILLER

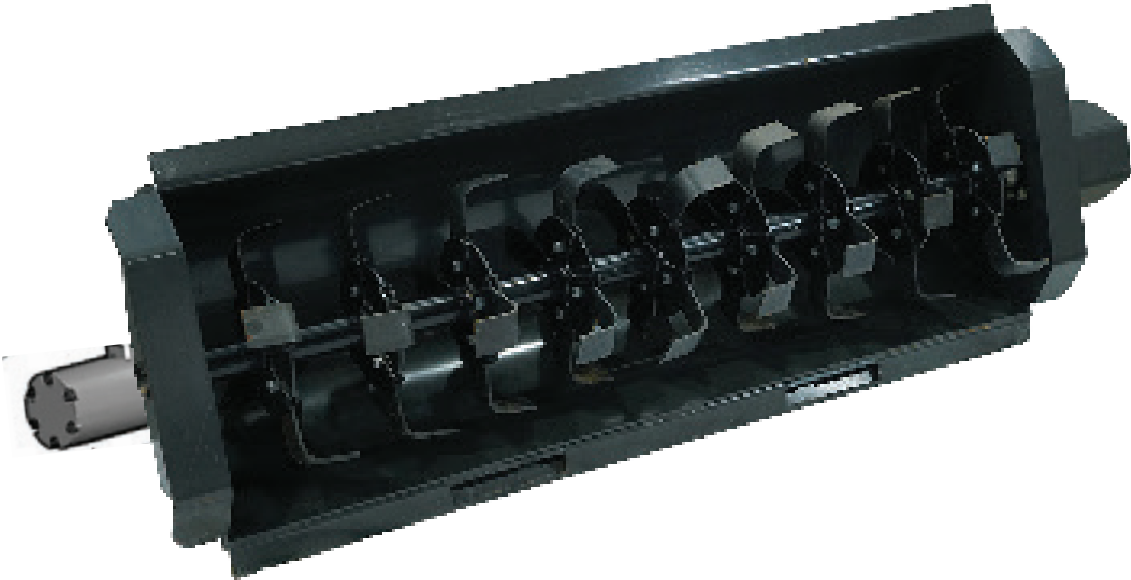

72" LOW FLOW ROTARY TILLER*

7.2 PARTS DIAGRAM

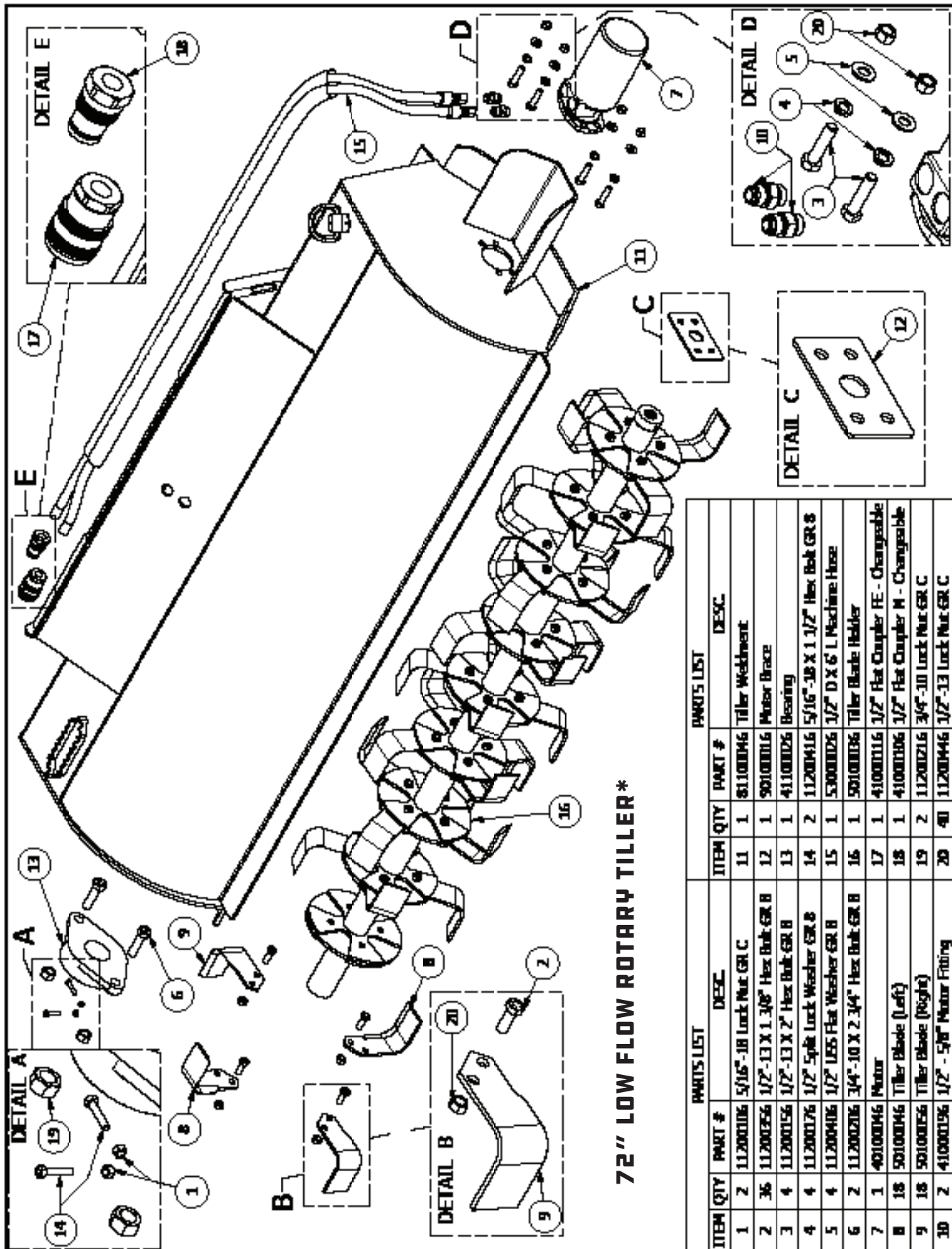

72" LOW FLOW ROTARY TILLER*

PARTS LIST		PARTS LIST					
ITEM	QTY	PART #	DESC.	ITEM	QTY	PART #	DESC.
1	2	11200106	5/16"-18 Lock Nut GR C	11	1	81100046	Tiller Wheelnut
2	36	11200156	1/2"-13 X 1.348" Hex Bolt GR H	12	1	90100016	Motor Brace
3	4	11200156	1/2"-13 X 2" Hex Bolt GR H	13	1	41100026	Bearing
4	4	11200176	1/2" Split Lock Washer GR B	14	2	11200416	5/16"-18 X 1 1/2" Hex Bolt GR B
5	4	11200406	1/2" 1255 Flat Washer GR H	15	1	53000026	1/2" D X 6" L Machine Hose
6	2	11200206	3/4"-10 X 2 3/4" Hex Bolt GR H	16	1	50100036	Tiller Blade Holder
7	1	40100046	Motor	17	1	41000116	1/2" Flat Coupler RE - Changeable
8	18	50100046	Tiller Blade (Left)	18	1	41000106	1/2" Flat Coupler M - Changeable
9	18	50100056	Tiller Blade (Right)	19	2	11200216	3/4"-10 Lock Nut GR C
10	2	41000196	1/2"-5/8" Motor Fitting	20	40	11200446	1/2"-13 Lock Nut GR C

*HIGH FLOW ROTARY TILLER HAS SECOND MOTOR INSTEAD OF BEARING ASSEMBLY NOTED IN DETAIL A

SECTION 8

WARRANTY INFORMATION

LIMITED WARRANTY

Construction Implements Depot, Inc. (CID) products are warranted to be free from defects in workmanship or materials for a period of 12 months from the initial sale.

WARRANTY EXCLUSIONS

This warranty does not cover normal wear items, including but not limited to: bearings, hoses, blade holders, ground engaging parts such as teeth, blades, cutting edges, pilot bits, auger teeth and broom bristles. This warranty does not cover maintenance, service or adjustments. This warranty does not cover damage due to improper application or installation, misuse, negligence, accidents or improper maintenance. Please note: Any modification or customization made to your attachment may void its warranty. This warranty is void if any components have been disassembled, i.e., pumps, gear boxes or motors or the attachment has been used without the case drain attached (if applicable). Be sure to follow all recommended Horsepower and GPM requirements as outlined in product specifications, in order to prevent the warranty from being void. This warranty is contingent upon the use of approved BRAND parts exclusively. Any use of non-approved parts may result in voiding the warranty. Please be advised that the warranty does not cover refurbished attachments. Specially modified attachments built by the manufacturer to meet your needs shall not be warranted by CID, Inc.

REPAIRS UNDER WARRANTY

Any repairs, including welding, on attachments must be performed by certified repair technicians who have requested and obtained written approval from an authorized representative of CID before repairs begin. If you are completing the repair, you must also have prior written approval to prevent the warranty from being voided.

WARRANTY STATEMENT

Our obligation under this Limited Warranty shall be solely limited to repairing or replacing any part (see non-covered items above) that, according to our judgment, show evidence of a defect in quality of workmanship or materials for the stated 12 month warranty period. All defective parts must be routed directly to CID, Inc. with

8.0 WARRANTY INFORMATION CONT.

WARRANTY STATEMENT CONT.

freight or delivery charges to be prepaid. This limited warranty shall not be interpreted to render CID, Inc. liable for any injury or damage to persons, businesses or property of any kind nor expenses or losses incurred for labor, supplies, substitute machinery rental or for any other reason. Repair or replacement parts are subject to the supply conditions at the time of repair or replacements, which may directly affect our ability to obtain material and/or replacement parts. CID, Inc. reserves the right to make improvements in design or changes in specifications at any time without incurring any obligations to owners of previously purchased products. No one but CID, Inc. is allowed to alter, modify or enlarge this warranty nor the exclusions, limitations and reservation at any time. CID, Inc. products are warranted to be free from defects in workmanship or materials for a period of 12 months from the initial sale.

Purchaser and Manufacturer hereby (a) submit to the non-exclusive jurisdiction of the courts of competent jurisdiction in North Carolina and Davidson County in which this company resides for resolution of any dispute concerning this Limited Warranty or the rights or obligations of Purchaser and/or Manufacturer; (b) agree that any litigation in connection with this Limited Warranty shall be venued in North Carolina and Davidson County in which the company resides and (c) waive any objection they may have as to any such action or proceeding brought in such court that such court is an inconvenient forum. Nothing herein shall limit the right of Purchaser or Manufacturer (or the right of any permitted successor or assign of either) to bring proceedings against the other in the courts of any other jurisdiction wherein any assets of such other party may be located.

8.1 WARRANTY RETURN AUTHORIZATION POLICY

WARRANTY RETURN AUTHORIZATION POLICY:

If repairs are required, a Return Material Authorization (RMA) number must be obtained for the defective part as well as proof of purchase. RMA and services are rendered by CID only. Any responsibility of shipping costs on any item returned for repair is at the discretion of CID, Inc.

All returned parts must have the following:

1. A legible RMA number written on the outside of the package.
2. Warranty Claim Form (online)
3. The defective part.

RMA numbers are only valid for 30 days from the date of issue. All shipped replacement parts will require a Parts Order (PO) number from the original CID, Inc dealer. Repairs not covered by the warranty, will be charged for parts and labor at the current pricing rate. Should you have any problems with your attachment, please follow the instructions listed on the following page.

8.2 WARRANTY PROCEDURE

WARRANTY RETURN AUTHORIZATION PROCEDURE:

1. Call the Warranty Department at (336) 859-2002 EXT 215. You will need to provide the model and serial number of the defective item(s) (see Appendix for where to find this information), a description of the problem, and have photographs available.
2. Upon a warranted issue, visit www.cidattachments.com, click on the warranty tab, and fill in the warranty information on the Warranty Claim Form. CID, Inc will retain a Return Material Authorization (RMA) number of the defective part. If all the information above is completed CID, Inc will issue a RMA number via email.
3. Once you have an approved RMA number, a shipping label will be provided with CID's address and instructions for returning the defective part. **Appropriate RMA's/PO's will be invoiced and payment received while the evaluation process is being completed to prevent delays in your normal business operations. In the event the defective part(s) is un-warranted and repairs are not covered by the warranty, the customer will be invoiced for any additional parts and labor at the current pricing rate. If the part is deemed under warranty, a credit of the invoice will be issued.**
4. CID will ship a replacement part to the provided location or customer with a RMA identifier of some kind. **The customer is responsible for initial shipping charges until evaluation of the part has been completed.** If the part failure is covered by the warranty, the customer will be reimbursed for any paid shipping charges. In the event, the part is not covered by the warranty, the customer is responsible for return shipping.
5. Once the defective part is warranted by CID, the customer will be issued a credit and the PO number will no longer be active.
6. In the event CID decides that the attachment needs to be returned to them for repair, CID will make arrangements for pickup and return. Repairs will be performed by CID qualified technicians. Non-warranted issues will be discussed, and repairs will be performed upon the owner's agreement and receipt of payment for parts and labor.

SECTION 9

SAFETY ACKNOWLEDGMENT

ATTENTION ALL OPERATORS: Print your name, sign and date in the boxes below to acknowledge that you have read and fully understand the safety instructions presented in this manual, and have been trained on how to safely operate this attachment.

OPERATOR NAME	SIGNATURE	DATE

APPENDIX A FINDING YOUR MODEL AND SERIAL NUMBER

The Model and Serial numbers will either be etched into the attachment or on a Data Plate.

Instructions: Stand at the back of the attachment facing the attachment mounting bracket and look in the following locations:

Top- left or right

PLEASE NOTE: The Model and Serial number may be etched or on a Data Plate.

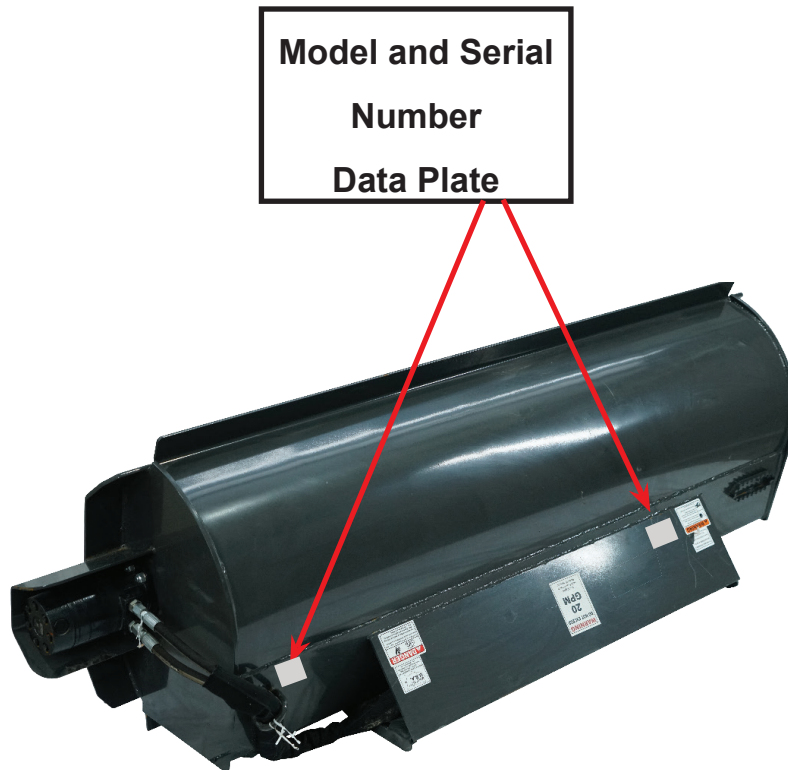

Disclaimer: Any critical changes made to this manual by individuals outside the manufacturer's authorized personnel are doing so at their own risk. The manufacturer cannot be held legally responsible for any consequences, damages, or liabilities resulting from such modifications. It is advised to adhere strictly to the original manual provided by the manufacturer for optimal performance, safety, and reliability.

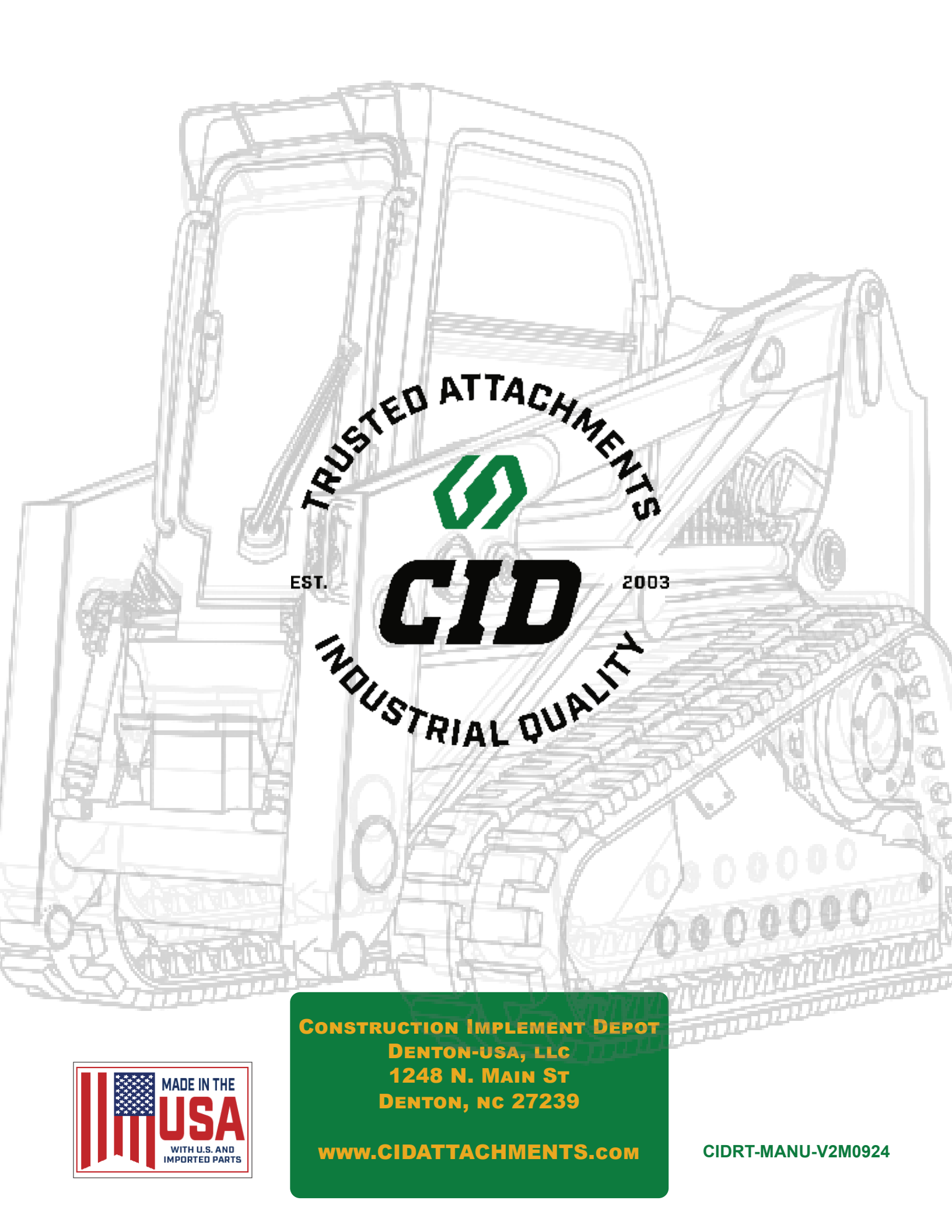

TRUSTED ATTACHMENTS



EST.

CID

2003

INDUSTRIAL QUALITY

**CONSTRUCTION IMPLEMENT DEPOT
DENTON-USA, LLC
1248 N. MAIN ST
DENTON, NC 27239**

www.CIDATTACHMENTS.COM

CIDRT-MANU-V2M0924

