



Standard, Heavy Duty & X-treme Other Hydraulic Attachments



Owner's/Operator's Manual



WARNING

For safe operation, read these rules and instructions carefully to avoid accidents that could result in Death or Serious Injury.

TO THE OWNER/OPERATOR OF THIS IMPLEMENT

Please read this manual "before" unpacking or using this implement for the first time. This manual provides you with the necessary instructions to safely install and use your purchase. Do not let other people use this attachment without first being instructed how to safely use it.



Construction Implements Depot, Inc

1248 N. Main Street

Denton, NC 27239

(336) 859-2002

Save this manual for future reference!

Thank You

Our sincere appreciation to you on the purchase of a quality hydraulic attachment designed and manufactured in the USA by Construction Implements Depot, Incorporated. Product experience of a combined 30 years is the cornerstone of our company, and our goal is to provide you with a heavy duty product that will give you years of satisfaction and operation.

Our record of successful and satisfied customers is evidence of the concern for quality and designed strength that we place into each and every product we build.

As this manual expresses the need for safe operation of your acquisition from Construction Implements Depot, Inc, it is important that you and all operators of this implement become familiar with the operation, maintenance and safety instructions found in this manual, as well as in the manual that accompanied the skid steer machine that will power this attachment. Add some common sense to the items mentioned in these manuals as the recipe for safe operation.

We invite you to look at more innovative products on our web site:
<http://www.cidattachments.com> or if in the area stop and visit our modern manufacturing facilities located in Denton, NC.

Sincerely,
Management & Employees
Construction Implements Depot, Inc.

Information

Record product information here for future reference

Model (✓) **4-N-1 Bucket** - Light Duty _____ Heavy Duty _____ X-treme _____
60" ___ 63" ___ 66" ___ 72" ___ 78" ___ 81" ___ 84" ___

High Dump Bucket - 72" ___ 84" ___

Snow Plow - 72" ___ 84" ___ 96" ___

Tree/Post Puller _____

Hay Bale Squeezer _____

S/N or MFG. Date _____ Date of Purchase ___/___/___

Dealer Name _____ Dealer Phone ___-___-___

Table of Contents

Orientation Examples 3

Importance of Safety 3

Operator Safety Training Tips 4

Skid Steer Requirements 5

Unpacking Your Shipment 5

Using Your Implement 5

 Connecting Attachment to Skid Steer 5

 Pre-Operation Walk-around Inspection 6

 Hydraulic Attachment Controls 6

 Before Using the Attachment the First Time 7

 Getting Familiar with the Attachment 7

 Before Starting 8

 Attachment Tips 8

Maintaining your Attachment 9

 Before Every Use 9

 Every Week 10

 After Every Season 10

 Cutting Edge Removal & Replacement 10

 Hydraulic System 10

 Hardware Torque 11

Specifications 11

Parts 14

 Bale Squeezer 15

 High Dump Bucket 16

 Tree/Post Puller 17

 4 N 1 Bucket 18

 Snow Plow 19

 Decals 20

Troubleshooting 21

Limited Warranty 24

Orientation Examples

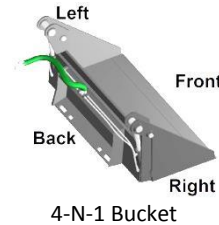
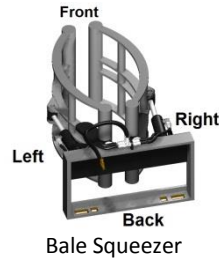

Serial Number Plate is Located on Top of Mounting Plate

Importance of Safety

Accidents can be very costly to human life and property. As the operator is the #1 safety device on all types of vehicles or equipment, it is important that the operator read, learn and know all safety recommendations for this product. The user is responsible to his family, friends and co-workers to operate in a safe manner. Ensure that everyone who operates or assists in the operation or maintenance of this product read and understand all the elements required to safely operate this piece of equipment.

This attachment has moving parts that include additional dangers.

Throughout this manual you will find safety notes which are very important to read and understand before operating this piece of equipment.

These classifications alert you to situations that could be harmful to you or bystanders. When you see these alerts in the manual, carefully read and follow all instructions and also protect other workers from the same danger.

 **DANGER** Will result in Death or Serious Injury.

 **WARNING** Could result in Death or Serious Injury.

 **CAUTION** Could result in Minor or Serious Injury.

 **NOTICE** Not related to Personal Injury.

Operator Safety Training Tips

It is the responsibility of the operator using this attachment to be acquainted with the safe operation. In addition to reading this manual, it is important that the operator read the skid steer's operation manual and follow its manufacturer's recommendations!

 Before digging into any surface, always contact the "Diggers Hotline" to identify underground utilities to avoid an accident that could result in Death or Serious Injury to the operator or fellow workers.

 Before lifting, lowering or tilting the attachment, make sure the area is clear of bystanders or objects.

 Machinery parts sometimes have sharp edges. Wear work gloves when moving parts. Always use caution around attachment parts as they often are very sharp.

 Never use drugs or alcoholic drinks when operating or servicing this piece of equipment.

 Always wear the proper personal protection equipment when servicing or operating this piece of equipment. Never service or operate this attachment with bare feet, sandals, or other light footwear.

 Always use eye protection during operation.

 Speed Kills! Operate this implement at a safe working speed. When transporting the implement, keep a safe speed to avoid losing control of the attachment or prime mover.

 Keep proper clearance between the implement and objects (utilities, tree stumps, large rocks, buildings, etc.). Contacting these objects with the implement or prime mover could cause a loss of control or damage to the implement or property.

 Before each operation of this implement, check all hardware (bolts, nuts, pins, etc.) for their proper location and tightness.

 Stop the engine on the skid steer and set the brake to avoid the implement rolling forward or backwards while you are exiting the prime mover.

 Store this implement in an area not frequented by children.

 Allow no riders on this attachment. Keep all bystanders clear of attachment during operation.

 Always replace worn, torn or missing safety decals before operating.

 Never operate the attachment when bystanders are within 10 feet (3 m) of the work area.

 Operate only during daylight or well-lit artificial light.

 If working on public roadway, display a Slow Moving Vehicle emblem per your State & Local regulations. Turn your flashers on.

Skid Steer Requirements

Your hydraulic attachment must be connected to a skid steer with adequate horsepower and weight to provide satisfactory results. Tracked loaders will provide superior traction in ground engaging applications and wheeled loaders may provide the best option for above ground material handling applications.

The attachment plate on your hydraulic attachment will connect to the couplers on most major brand skid steer loaders. Do not modify the attachment plate on this attachment to fit older styles of attachment couplers on older machines. Contact your skid steer loader dealer to supply an updated coupler on an older skid steer to fit this attachment.

Your skid steer must also be equipped with an auxiliary circuit that is available on the loader arms and is controlled by a switch, pedal or handle inside the skid steer loader cab.

 **CAUTION** Make sure your skid steer is in good working condition. Follow the operating instructions found in the manual that

accompanied your skid steer. Failure to do so could result in Minor or Serious Injury.

Unpacking Your Shipment

Your attachment arrives from the factory banded to a wooden pallet, and requires no final assembly before use.

 **CAUTION** Careless removal of the shipping bands that secure the implement to the pallet could result in Minor or Serious Injury. Clear the area of all bystanders and stand to the side when cutting the bands with a pair of sheet metal shears.

Using Your Implement

Connecting Attachment to Skid Steer

 **DANGER** Never enter the area underneath the coupler or any part of the attachment when it is in the raised position to avoid an accident that will result in Death or Serious Injury.

Verify that the hydraulic hoses are clear from the front of the attaching plate on the attachment and that the mounting plate is free from dirt and debris. When clear, move the skid steer to proximity of attachment plate. Tilt skid steer coupler forward to align coupling point with the upper part on the attachment plate and raise the coupler slightly.

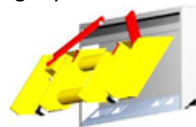

Connecting Coupler to Attachment

When the top edge of the coupler is seated in the top part of the coupler plate, roll the skid steer tilt function back until the attaching plate is flat against the skid steer coupler. Lock down the coupler levers. Note: If your skid steer is equipped with a hydraulically operated coupler, activate the coupler lock at this time.

○

PLEASE NOTE:
Attachment and Machine-side Couplings must be
FREE OF DEBRIS
BEFORE INSTALLING.
Failure to comply will void
warranty.

NOTICE *Wipe off any dirt or dust from the male or female hydraulic flat-face couplers with a clean rag before attaching hoses, to keep contaminants from entering the hydraulic system.*

Connect the attachment hydraulic hoses to the auxiliary supply couplers located on your skid steer loader lift arm.

Check the surrounding area for bystanders and clear them before starting the skid steer or attachment.

Before operating the attachment, always visually inspect and verify that the coupler lock pins are fully engaged through the latch slots on the attachment plate.

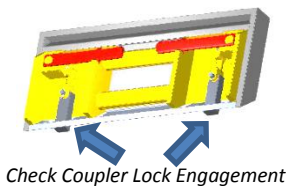

Pre-Operation Walk-around Inspection

Before every use, it is important to perform a short inspection and certain maintenance on your hydraulic attachment.

	Item
✓	Check that all shields and guards are in place.
✓	Look for loose bolts and tighten them if necessary.
✓	Check that all safety decals are in place and can be read. Replace them if necessary.
✓	Take care of our environment. Repair any hydraulic leaks.

Hydraulic Attachment Controls

Your hydraulic attachment is designed to run off the skid steer loader auxiliary hydraulic system by a control switch, pedal or handle in the operator's cab. Consult your skid steer operator's manual for precise instructions on how to activate, reverse and neutralize the auxiliary circuit.

Height and tilt functions of the attachment are operated with the control handles or pedals in the cab. Consult your skid steers operator's manual for precise instructions regarding these functions.

Your skid steer may have a "float" function on the lowering circuit. When placed in the float position, the attachment will follow the contour of

the ground being worked. See your skid steer's Operator's Manual for instructions about how to use the float on your skid steer.

If during your initial startup you realize the hydraulic function operates in the opposite direction that you prefer, you can change positions of the quick disconnect couplers on the attachment hoses to remedy your problem.

Before Using the Attachment the First Time

⚠ WARNING *Moving the attachment with bystanders in the area could result in Death or Serious Injury. Before moving the attachment or machine, always make sure the area is clear of bystanders.*

NOTICE *If this is your initial startup with this attachment on this machine, check the skid steer's hydraulic oil level and add oil, if necessary, before and after doing steps 1 & 2 below.*

After starting skid steer, lift the attachment 10" (254mm) off the ground surface:

1. With the skid steer engine RPMs just above idle, slowly engage the auxiliary hydraulic flow to the attachment cylinder arm until the function operates. Reverse the direction of the hydraulics until the function has been placed in the opposite direction. Repeat this two more times to purge any air from the system.
2. Lower the attachment to the ground and shut off the skid steer's engine and exit the operator's compartment.

3. Check the skid steers hydraulic oil level, and add oil if necessary.
4. Inspect the attachment's hydraulic plumbing for any noticeable leaks. Correct these leaks before continuing.

Getting Familiar with the Attachment

⚠ DANGER *Never operate the attachment when bystanders are within 10' (3 m) of your work area.*

⚠ CAUTION *Be cautious when operating on un-level ground surfaces. A machine roll over could result in Minor or Serious Injury. Always wear your seat belt when operating this type of machinery.*

Before starting the engine with this attachment connected to the skid steer, make sure you are knowledgeable and comfortable with the operation of the auxiliary hydraulic control as outlined in the previous sections of this manual and that in the skid steer loader Owner's Manual.

When operating this attachment, set the skid steer throttle at a speed that will produce the required flow, to the attachment and the other loader functions. If the skid steer is equipped with a foot throttle, use it to control engine speed and power being delivered to the attachment. Refer to your skid steer manual or call your local skid steer dealer for additional help, if necessary.

To begin with, learn what the attachment looks like in a level position when you are seated in the skid steer. Knowing what a level implement looks like will help you with your attachment operation.

The correct ground speed for using this attachment will depend on the application and conditions and usually can be monitored by sound and feel and depends on the material density. If the skid steer engine is bogging down because of taking too big of a “bite” with the attachment, it will be necessary to raise or decrease the load a little until the machine’s power can overcome the material load on the attachment.

Before Starting

⚠ WARNING *Before digging into any surface, always contact the “Diggers Hotline” to identify underground utilities to avoid an accident that could result in Death or Serious Injury to the operator or fellow workers.*

⚠ WARNING *Exposure to crystalline silica dust along with other hazardous dusts may cause serious or fatal respiratory disease. It is recommended to use dust suppression, dust collection and if necessary personal protective equipment during the operation of any attachment that may cause a high level of dust.*

Inspect the area to be worked and make sure it is free of any utilities, rocks, fence posts, or any other objects that you do not want to move.

Determine a safe and efficient duty cycle pattern before the start of the job.

Attachment Tips

⚠ CAUTION *Never operate this attachment when bystanders are in proximity of the work area that could result in Minor or Serious Injury*

by contact with the machine, attachment or flying debris.

1. Always inspect the work area before starting the job. Locate and mark any utilities, steel posts, rocks or any other objects that could be damaged or would damage the blade during operation. Never assume the work area is safe and never skip the inspection part before start of operation.
2. Operate at a safe slow-paced speed that will allow you to watch the area ahead and behind the attachment & loader. Since about half of your duty cycle may be in reverse, look behind you and/or utilize your mirrors when backing up. Verify that your backup alarm is working properly to warn others when you are in reverse, but never think that the alarm replaces your responsibility to visually check what’s behind you.
3. Attachment control is the most important element to getting a good, steady cut. Overloading the attachment will only result in spinning the tracks or tires and will make unwanted ruts. Overloading the attachment will also necessitate raising the implement to off load some of the resistance occurring by the material. When you raise the attachment, you will create an unlevelled surface that will increase as the front of the prime mover drives over the rise of the ground surface.
4. If you lift too heavy a load with your attachment, you may raise the rear of your skid steer, and further reduce your tractive power available to move the load.
5. Before beginning your forward motion with the attachment, stop the skid steer and make any final

adjustments to the attachment in terms of height & tilt.

6. (4-N-1) When picking an object up with the clam, center your load on the attachment. Estimate the load center and pick it accordingly. If the load feels unbalanced when you lift it, reposition your grab and retry the lift. An unbalanced load could upset your skid steer.
7. (4-N-1) After loading your attachment and clamping the arms over the load, roll the attachment back and retighten the clamp arm pressure. When rolling back the attachment, the load will settle and require some additional clamping pressure to secure the load.

⚠ WARNING When lifting a load of brush or trees, make sure all ends are not tangled with standing trees that could cause the center of gravity to be compromised, resulting in a rollover that could cause Death or Serious Injury.

8. The 4-N-1 clam should not be used for pushing or pulling down trees or any type of structure.
9. To save some service work and down time, always pay attention that tree branches or roots do not poke through past the attachment arms and damage any hydraulic parts or even enter the cab area.
10. Be careful that a branch or root doesn't "whip" back at the skid steer. Wear safety glasses to prevent dirt getting in your eyes.
11. (Bale Squeezer) Be aware of soft ground conditions.
12. (Bale Squeezer) Always carry the bale as low to the ground as possible to avoid a roll-over. When lifting a bale to position it in a stack, drive up to the location, stop the forward movement of the skid steer, then, raise the bale to

the required height. Proceed forward slowly.

⚠ WARNING Use extreme caution when working around low hanging electrical lines. Do not raise the attachment in an area where there are low electrical lines to prevent an accident that could result in Death or Serious Injury.

13. Keep your distance from any type of utility, whether underground or in the air.
14. Always clean the quick-disconnect couplers before connecting them to the skid steer. Utilize plastic or metal caps to protect the ends when not being used. Tuck the quick disconnect hoses somewhere in the attachment where they will be out of the dirt and will not be driven over.
15. (Tree/Pole Puller) Do not overload the capacity of your skid steer or attachment. Be selective in your choice of trees to remove with this attachment.

Maintaining your Attachment

Before Every Use

Check that all fasteners (nuts, bolts, pins, keepers) are in their right place and are tight.

Inspect and replace any worn, torn or missing safety decals.

Investigate the location of any oil leaks and repair.

Lubricate all pivot joints with #2 lithium grease.

Every Week

Check the condition of the cutting edge and/or tooth points (if equipped). Order parts if the cutting edge or points are becoming worn and replace as soon as possible.

After Every Season

Inspect the implement for any loose or worn parts that may need to be replaced prior to the next season.

Visually inspect the cutting edge (if equipped). Replace, if necessary.

Clean, sand & repaint any area that looks worn or scratched to prevent further rusting. Use an equipment-paint found at your local hardware store or building center.

Replace any warning decals that have been lost or damaged.

Store your implement in a shed or cover with a water-proof tarp to protect it from the weather. Store in an area not frequented by children.

Cutting Edge Removal & Replacement

⚠ WARNING *To avoid an accident that could result in Death or Serious Injury, never find yourself in a position where any body part is located under an unsupported blade or frame when servicing this attachment.*

⚠ WARNING *Hazardous dust can be generated if painted surfaces are heated or welded and could result in death or Serious Injury. Remove paint before welding and always make repairs in a well-ventilated area and wear an approved respirator.*

⚠ CAUTION *Cutting edges can be very heavy and could cause Minor or Serious Injury if mishandled. Always wear protective gloves and footwear.*



1. Weld-on cutting edge replacement is not a task for most machinery operators and should be referred to a welding shop that possesses the proper equipment, knowledge and experience.
2. Replacement cutting edges are available from your CID dealer.

Hydraulic System

⚠ WARNING *A small stream of oil from a pinhole leak could penetrate your skin if contacted. To avoid an accident that could result in Death or Serious Injury, never use your hand or other body parts in an attempt to locate a hydraulic leak.*

NOTICE *Always release the hydraulic system pressure from the hydraulic circuits prior to removing the attachment or any hydraulic system service work.*

Hardware Torque

	Grade 2 lb-ft	Grade 5 lb-ft	Grade 8 lb-ft
			
¼"	66*	8	12
5/16"	10	17	20
3/8"	20	30	45
½"	45	75	110

¾"	160	260	380
7/8"	190	400	600
1"	-	580	900

* = inch pounds

Higher torques require the use of a torque multiplier.
All values are "dry" torques.

Specifications

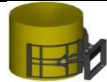

Spec.	Bale Squeezer	
		
Closed Width	30" (762 mm)	
Length	69.2" (1758 mm)	
Opening Width	79.3" (2014 mm)	
Weight	691 lbs. (313 kg)	
Capacity	2800 lbs. (1270 kg)	
SSL Auxiliary Hyd. Circuits Required	1	
Hyd. Relief Setting	3000 PSI (207 bar)	

Spec.	High Dump Bucket		
			
Width	72" (1829 mm)	84" (2134 mm)	96" (2438 mm)
Length	35" (889 mm)		
Opening Width	37.7" (958 mm)		
Weight	950 lbs. (431 kg)	1025 (465 kg)	
Capacity	2800 lbs. (1270 kg)		
SSL Auxiliary Hyd. Circuits Required	1		
Hyd. Relief Setting	3000 PSI (207 bar)		

Spec.	Tree/Post Puller		
			
Width (Coupler)	45.6" (1158 mm)		
Length	31.1" (790 mm)		
Weight	300 lbs. (136 kg)		
Capacity- Tree Post	8' (203 mm) Diameter		
SSL Auxiliary Hyd. Circuits Required	1		
Hyd. Relief Setting	3000 PSI (207 bar)		

Spec.	Light Duty 4-N-1 Bucket		
			
Width	60" (1524 mm)	66" (1676 mm)	72" (1829 mm)
Length	25.3" (643 mm)		
Opening Width	31.8" (808 mm)		
Weight (less teeth)	600 lbs. (272 kg)	625 lbs. (284 kg)	650 lbs. (295 kg)
SSL Auxiliary Hyd. Circuits Required	1		
Hyd. Relief Setting	3000 PSI (207 bar)		

Spec.	Heavy Duty 4-N-1 Bucket		
			
Width	63" (1600 mm)	66" (1676 mm)	72" (1829 mm)
Length	25.3" (643 mm)		
Opening Width	31.8" (808 mm)		
Weight (less teeth)	785 lbs. (356 kg)	810 lbs. (367 kg)	850 lbs. (386 kg)
Weight (with teeth)	829 lbs. (376 kg)	875 lbs. (397 kg)	900 lbs. (408 kg)
SSL Auxiliary Hyd. Circuits Required	1		
Hyd. Relief Setting	3000 PSI (207 bar)		

Spec.	X-treme 4-N-1 Bucket			
				
Width	72" (1828 mm)	78" (1981 mm)	81" (2057 mm)	84" (2134 mm)
Length	33.8" (856 mm)			
Opening Width	32" (812 mm)			
Weight (less teeth)	1150 lbs. (522 kg)	1255 lbs. (569 kg)	1295 lbs. (587 kg)	1332 lbs. (604 kg)
Weight (with teeth)	1210 lbs. (549 kg)	1305 lbs. (592 kg)	1350 lbs. (612 kg)	1395 lbs. (633 kg)
SSL Auxiliary Hyd. Circuits Required	1			
Hyd. Relief Setting	3000 PSI (207 bar)			
Spec.	X-treme Snow Plow			
				
Width	72" (1829 mm)	84" (2134 mm)	96" (2438 mm)	
Length	47.8" (1214 mm)			
Height	34" (864 mm)			
Angle	21°			
Weight	722 lbs. (327 kg)	822 lbs. (373 kg)	944 lbs. (428 kg)	
SSL Auxiliary Hyd. Circuits Required	1			
Hyd. Relief Setting	3000 PSI (207 bar)			

Parts

As this manual includes many different types of CID hydraulic attachments, please take care in selecting the parts from the correct parts pages!

When requiring any parts for your implement, please collect the following information:

Implement Model Number
Implement Serial Number
Attachment Width
Parts Manual Date (lower right corner)
Parts Manual Page
Part Description
Quantity Required
Ship-to Name & Address
Payment Method

...then call your local dealer for factory fresh parts specifically designed for your attachment.



Bale Squeezer

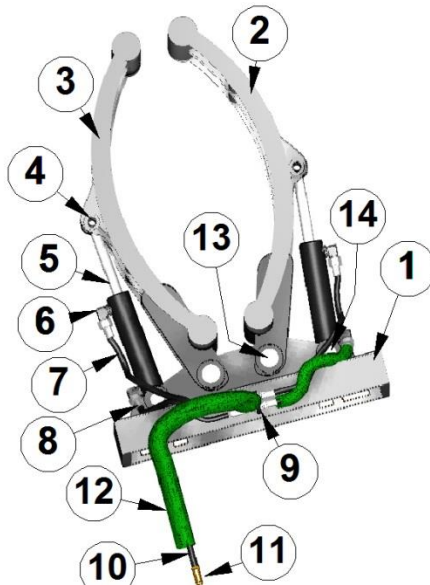

Ref.	Description	Qty.
1	Frame Weldment	1
2	Squeezer Arm Weldment - RH	1
3	Squeezer Arm Weldment - LH	1
4	Pin, Cylinder Rod End to Squeezer Arm	2
5	Cylinder, frame to Squeezer Arm	2
6	Elbow 90°, Hoses to Cylinder	4
7	Hose , Tee to Rod End of Cylinder	2
8	Hose, Tee to Base End of Cylinder	2
9	Tee	2
10	Hose, Quick Disconnect to Tee	2
11	Quick Disconnect Set	1
12	Sleeve, Protective Hose – Specify Size & Length	A/R
13	Pin, Squeezer Arm to Frame	2
14	Pin, Cylinder to Frame	2+

High Dump Bucket

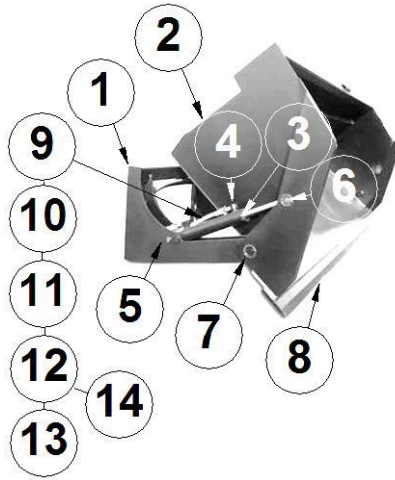

Ref.	Description	Qty.
1	Frame Weldment	1
2	Bucket Weldment	1
3	Dump Cylinder	2
4	Elbow 90°, Hoses to Cylinder	4
5	Pin, Cylinder Base End to Frame	2
6	Pin, Cylinder Rod End to Bucket	2
7	Pin, Pivot Between Bucket & Frame	2
8	Cutting Edge, Weld-on	1
9	Hose, Tee to Rod End Of Cylinder	2
10	Hose, Tee to Base End of Cylinder	2
11	Tee, Between Supply Hoses and Cylinders	1
12	Hose, Tee to Quick Disconnects	2
13	Quick Disconnect, Set	1
14	Sleeve, Protective Hose – Specify Size & Length	AR

Specify Bucket Width When Ordering Parts

Tree/Post Puller

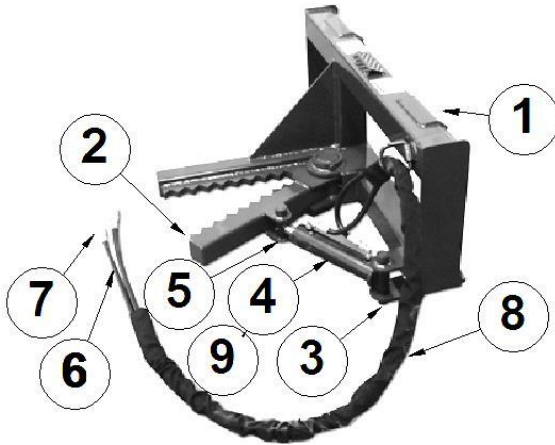

Ref.	Description	Qty.
1	Frame Weldment	1
2	Jaw Arm	1
3	Pin, Cylinder Base to Frame	1
4	Cylinder	1
5	Pin, Cylinder Rod End to Jaw Arm	1
6	Hose Set	1
7	Quick Disconnect Set	1
8	Sleeve, Hose Protection	1
9	Elbow 90°, into Cylinder	2

4 N 1 Bucket

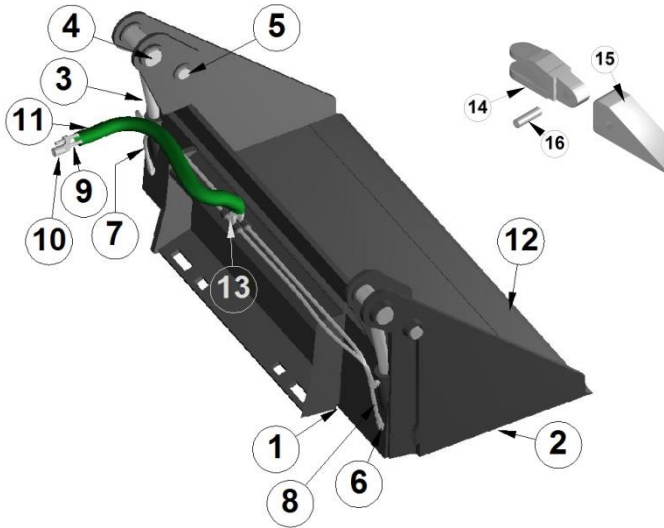

Ref.	Description	Qty.
1	Frame Weldment	1
2	Clam Weldment	1
3	Cylinder	2
4	Pin, Rod End of Cylinder to Clam	2
5	Pin, Clam Pivot	2
6	Elbow 90°, into Cylinder	4
7	Hose, Cylinder Rod End to Tee	2
8	Hose, Cylinder Base End to Tee	2
9	Hose Set, Tees to Quick Disconnects	1
10	Quick Disconnect Set	1
11	Sleeve, Hose Protection – Specify Size & Length	A/R
12	Cutting Edge, Weld-on	1
14	Tooth Shank, Weld-on	A/R
15	Tooth Point	A/R
16	Roll Pin – Secures Tooth Point to Shank	A/R

Specify Bucket Width When Ordering Parts

Snow Plow

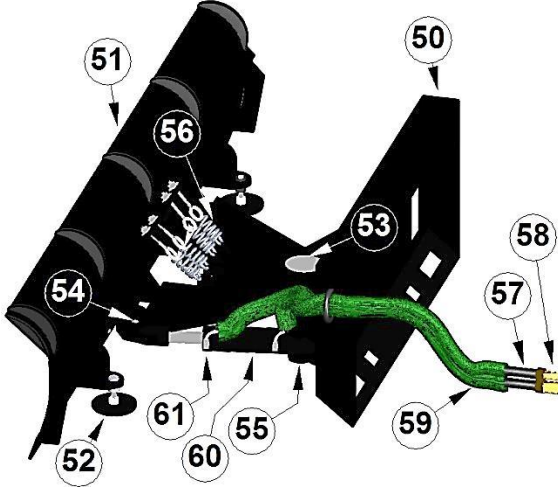

Ref.	Description	Qty.
50	Frame Weldment	1
51	Blade Weldment	1
	Wear Edge & Hardware Set	1
52	Skid	2
53	Pin, Angle Pivot	1
54	Pin, Rod End of Cylinder to Blade	1
55	Pin, Base End of Cylinder to Frame Weldment	1
56	Spring	4
57	Hose Set – Cylinder Ports to Quick Disconnects	1
58	Quick Disconnect Set	1
59	Sleeve, Hose Protection , Specify Width & Length	A/R
60	Cylinder	1
61	Elbow 90° in Cylinder	2

Specify Plow Blade Width When Ordering Parts

Decals

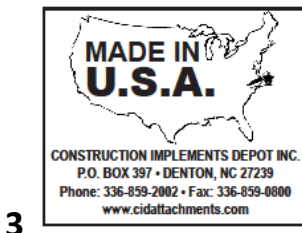

For warranty information
call your dealer or go to
www.CIDattachments.com/CID_warranty.html



Ref.	Description	Qty.
1*	Decal, (Danger Pinch Points)	2
2*	Decal, (Warning, High Pressure Fluid Hazard)	1
3	Decal, Made in the USA	1
4	Decal, Registration & Warranty Info	1
5	Decal, Construction Implements Depot, Inc.	1
6	Decal, Clean Debris from Hydraulic Couplers	1

***  WARNING** *Replace any worn, torn or missing safety decals before operating!*

Troubleshooting

Problem	Cause	Resolution
Hydraulic oil level goes down during operation	Leak at hoses on attachment	Investigate & repair
	Leak in skid steer hydraulic system	Investigate & repair
Cylinder does not open or close	Quick disconnects not connected	Check and recouple quick disconnects
	Hose damaged	Check for smashed or kinked hose and replace if found.
	Skid steer auxiliary circuit inoperative	Investigate and have repaired.
Cylinder moves very slow	Restricted hose	Check for damaged hose between skid steer & cylinders. If damaged, replace the hose.
	Circuit relief on skid steer bad	Investigate & have repaired.
	Auxiliary valve spool on skid steer not shifting properly	Investigate and have repaired.
	Cylinder seals by-passing	Have cylinder(s) repacked or replaced.

***Think Safety,
Every day!***



Owner's Manual **Other Hydraulic Attachments**

**1248 N. Main
PO Box 397
Denton, NC 27239**

Website
www.cidattachments.com
For More Information, Contact
sales@cidattachments.com
Phone: (336)859-2002

Limited Warranty

Construction Implements Depot, Inc. products are warranted to be free from defects in workmanship or materials for period of (12) months from initial sale, lease or rental date.

Warranty Exclusions

This warranty does not cover normal wear items, including but not limited to, bearings, hoses, ground engaging parts such as, teeth, blades, cutting edges, pilot bits, auger teeth and broom bristles. This warranty does not cover maintenance, service or adjustments. This warranty does not cover damage due to misuse, negligence, accidents, or improper maintenance. This warranty does not cover damage due to improper application, installation, contamination, adjustment or setup. This warranty does not cover improper modifications of product. This warranty is void if any components have been disassembled, i.e. pumps, gear boxes, motors.

Specially modified attachments built by CID X-treme Attachments to meet your customer's needs shall not be warranted by Construction Implements Depot, Inc. This warranty does not cover replacement parts not supplied by CID, Inc.

Warranty Statement

Our obligation under this Limited Warranty shall be solely limited to repairing or replacing any part (see non-covered items) free of charge that, according to our judgment, show evidence of a defect in quality of workmanship or materials for the stated (12) month warranty period. All defective parts must be routed directly to CID, Inc. with freight or delivery charges to be prepaid. This Limited Warranty shall not be interpreted to render CID, Inc. liable for any injury or damage to persons, business or property of any kind nor expenses or losses incurred for labor, supplies, substitute machinery rental, or for any other reason. Repair or replacement parts are subject to the supply conditions at the time of repair or replacements, which may directly affect our ability to obtain material and/or replacements parts. CID, Inc. reserves the right to make improvements in design or changes in specifications at any time without incurring any obligations to owners of previously purchased units. No one but CID, Inc. is allowed to alter, modify or enlarge this warranty nor the exclusions, limitation and reservation at any time.