



X-treme Log Splitters



Owner's/Operator's Manual



WARNING

For safe operation, read these rules and instructions carefully to avoid accidents that could result in Death or Serious Injury.

TO THE OWNER/OPERATOR OF THIS IMPLEMENT

Please read this manual "before" unpacking or using this implement for the first time. This manual provides you with the necessary instructions to safely install and use your purchase. Do not let other people use this attachment without first being instructed how to safely use it.



Construction Implements Depot, Inc

1248 N. Main Street

Denton, NC 27239

(336) 859-2002

Save this manual for future reference!

Thank You

Our sincere appreciation to you on the purchase of a quality Log Splitter designed and manufactured in the USA by Construction Implements Depot, Incorporated. Product experience of a combined 30 years is the cornerstone of our company, and our goal is to provide you with a heavy duty product that will give you years of satisfaction and operation.

Our record of successful and satisfied customers is evidence of the concern for quality and designed strength that we place into each and every product we build.

As this manual expresses the need for safe operation of your acquisition from Construction Implements Depot, Inc, it is important that you and all operators of this implement become familiar with the operation, maintenance and safety instructions found in this manual, as well as in the manual that accompanied the skid steer machine that will power this attachment. Add some common sense to the items mentioned in these manuals as the recipe for safe operation.

We invite you to look at more innovative products on our web site:
<http://www.cidattachments.com> or if in the area stop and visit our modern manufacturing facilities located in Denton, NC.

Sincerely,
Management & Employees
Construction Implements Depot, Inc.

Information

Record product information here for future reference.

Model (✓) <i>X-treme Log Splitters:</i>
Conventional Splitter _____
Inverted Splitter _____
Horizontal Splitter _____
 S/N or MFG. Date _____
 Dealer Name _____
 Dealer Phone ____ - ____ - _____
 Date of Purchase ____/____/_____

Table of Contents

Thank You 2

Information..... 2

Orientation 3

Importance of Safety 3

Operator Safety Training Tips 4

Skid Steer Requirements 5

Unpacking Your Shipment 5

Using Your Implement 5

 Connecting Splitter to Skid Steer.... 5

 Pre-Operation Walk-around
 Inspection..... 6

 Splitter Controls 6

 Before the First Split..... 7

 Stopping the Splitter 7

 Getting Familiar with the
 Attachment 7

 Starting the Job 8

 Log Splitting Tips 8

Maintaining your Attachment 9

 Modifications 9

 Before Every Use..... 9

 After Every Use..... 10

 After Every Season 10

 Hydraulic System..... 10

 Hardware Torque 10

Parts..... 11

 Conventional Log Splitter 12

 Inverted Log Splitter..... 13

 Horizontal Log Splitter..... 14

 Decals 15

Troubleshooting 16

Specifications..... 17

Limited Warranty..... 20

Orientation

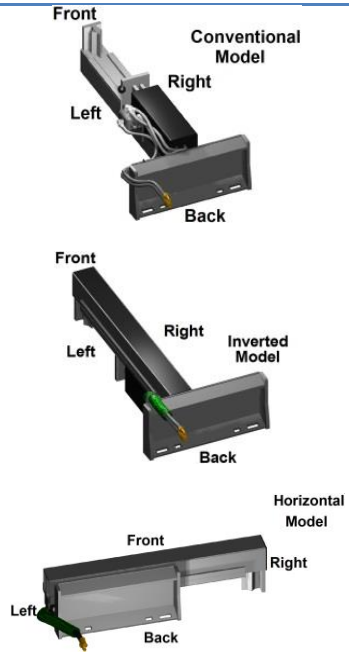

Serial Number Plate is Located on Top of Mounting Plate

Importance of Safety

Accidents can be very costly to human life and property. As the operator is the #1 safety device on all types of vehicles or equipment, it is important that the operator read, learn and know all safety recommendations for this product. The user is responsible to his family, friends and co-workers to operate in a safe manner. Ensure that everyone who operates or assists in the operation or maintenance of this product read and understand all the elements required to safely operate this piece of equipment.

This attachment has moving parts that include additional dangers.

Throughout this manual you will find safety notes which are very important to read and understand before operating this piece of equipment. These classifications alert you to situations that could be harmful to you or bystanders. When you see these alerts in the manual, carefully read and follow all instructions and also protect other workers from the same danger.

 **DANGER** Will result in Death or Serious Injury.

 **WARNING** Could result in Death or Serious Injury.

 **CAUTION** Could result in Minor or Serious Injury.

 **NOTICE** Not related to Personal Injury.

Operator Safety Training Tips

It is the responsibility of the operator using this attachment to be acquainted with the safe operation. In addition to reading this manual, it is important that the operator read the skid steer's operation manual and follow its manufacturer's recommendations!

 Before lifting or lowering the splitter, make sure the area is clear of bystanders or objects.

 Machinery parts sometimes have sharp edges. Wear work gloves when moving parts. Always use caution around the attachment as it may have a very sharp edge.

 Never use drugs or alcoholic drinks when operating or servicing this piece of equipment.

 Always wear the proper personal protection equipment when servicing or operating this piece of equipment. Never service or operate this attachment with bare feet, sandals, or other light footwear.

 Always use eye protection during operation.

 Operate this implement at a safe working speed. When transporting the implement, keep a safe speed to avoid losing control of the attachment or prime mover. Never allow riders.

 Never attempt to move this attachment from anywhere but when seated in the prime mover's operators seat.

 Stop the engine on the skid steer and set the brake to avoid the implement rolling forward or backwards while you are exiting the prime mover.

 Store this implement in an area not frequented by children.

 When operating the Conventional or Horizontal model splitter, never wear jewelry or loose clothing that could catch on any moving parts.

 Always replace worn, torn or missing safety decals before operating.

 Never allow juveniles or untrained people around the attachment or prime mover during operation.

 Use this attachment only during daylight or in well-lit artificial light.

Skid Steer Requirements

Your log splitter attachment is compatible with attachment couplers on all major manufacturers' skid steer machines. This splitter should only be used on skid steers with a compatible attachment coupler.

⚠ CAUTION *Make sure your skid steer is in good working condition. Follow the operating instructions found in the manual that accompanied your skid steer. Failure to do so could result in Minor or Serious Injury.*

Unpacking Your Shipment

Your splitter attachment arrives from the factory banded to a wooden pallet, and requires no final assembly before use.

⚠ CAUTION *Careless removal of the shipping bands that secure the implement to the pallet could result in Minor or Serious Injury. Clear the area of all bystanders and stand to the side when cutting the bands with a pair of sheet metal shears.*

Using Your Implement

Connecting Splitter to Skid Steer

⚠ DANGER *Never enter the area underneath the coupler or any part of the attachment when it is in the raised position to avoid an accident that will result in Death or Serious Injury.*

Verify that the hydraulic hoses are clear from the front of the attaching plate on the attachment and that the mounting plate is free from dirt and debris. When clear, move the skid steer to proximity of attachment plate. Tilt the skid steer coupler forward to align coupling point with the upper part on the back of the attachment plate and raise the coupler slightly.

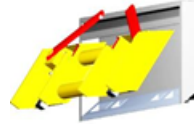

Connecting Coupler to Attachment

When the top edge of the coupler is seated in the top part of the coupler plate, roll the skid steer tilt function back until the attaching plate is flat against the skid steer coupler. Lock down the coupler levers. **Note:** If your skid steer is equipped with a hydraulically operated coupler, activate the coupler lock at this time.

Shut the Skid steer's engine off and release the pressure in the auxiliary circuit.

NOTICE *Wipe off any dirt or dust from the male or female hydraulic flat-face couplers with a clean rag before attaching hoses to keep contaminants from entering the hydraulic system.*

Connect the attachment hydraulic hoses to the auxiliary supply couplers located on your skid steer loader lift arm.

Check the surrounding area for bystanders and clear them before starting the skid steer or attachment.

Before operating the attachment, always visually inspect and verify that the coupler lock pins are fully engaged

through the latch slots on the attachment plate.

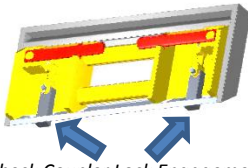

Check Coupler Lock Engagement

Pre-Operation Walk-around Inspection

Before every use, it is important to perform a short inspection and certain maintenance on your log splitter.

	Item
✓	Check that all shields and guards are in place.
✓	Look for loose bolts and tighten them if necessary.
✓	Check that all safety decals are in place and can be read. Replace them if necessary.
✓	Check that the valve handle is in the neutral position before starting the skid steer.
✓	Take care of our environment. Repair any hydraulic leaks.

Splitter Controls

Conventional Model Controls

The Conventional Log Splitter model is designed to operate from the skid steer’s auxiliary hydraulic system, and is activated by the control valve on the left side of the splitter. Before the conventional model can be operated, the skid steer’s auxiliary circuit must be activated and locked in the “ON”

position. Consult your skid steer operator’s manual for precise instructions on how to activate and deactivate the auxiliary circuit.

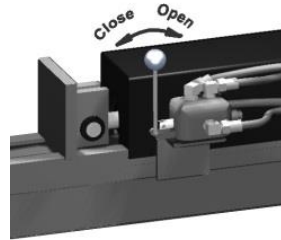

Conventional Model Control Valve

The control valve on the Conventional model has an auto-return feature. When the valve control is placed in the “Open” position, it will remain there until the operator returns the control handle to the neutral position. While the push block is returning to the open position, the operator can be positioning the next piece to be split onto the top of the beam.

NOTICE *Allowing the control handle to remain in the auto-return (open) position after the cylinder has fully retracted will result in the unnecessary over-heating of the skid steer’s hydraulic oil. Return the valve handle to the neutral position after it has retracted to the desired position.*

Inverted & Horizontal Model Controls

The Inverted & Horizontal models are controlled by the operator sitting in the cab of the skid steer loader. Extending & retracting the splitter’s cylinder is operated by activating the auxiliary pedal, lever or switch in the skid steer.

All Models - Height and tilt functions of the splitter are operated with the control handles or pedals in the cab.

Consult your skid steers operator's manual for precise instructions regarding these functions.

Before the First Split

NOTICE *If this is your initial startup with this attachment on this machine, check the skid steer's hydraulic oil level and add oil, if necessary, before and after doing steps 1, & 2 below.*

After starting the skid steer (and engaging the auxiliary flow lock on the Conventional Model):

1. With the skid steer engine RPMs just above idle, slowly engage the control to extend the splitter cylinder. Move the control in the opposite direction reversing the cylinder. Repeat this twice.
2. Lower the attachment to the ground. When the splitter is resting on the ground and the attachment coupler has been fully lowered, shut off the skid steer's engine and exit the operator's compartment.
3. Check the skid steers hydraulic oil level, and add oil if necessary.
4. Inspect the splitter's hydraulic plumbing for any noticeable leaks. Correct these leaks before continuing.

Stopping the Splitter

The splitter cylinder quits moving when the flow control is neutralized.

When you are done splitting, place the attachment on the ground before exiting the cab.

Getting Familiar with the Attachment

⚠ DANGER *Never operate the splitter when bystanders are within 10' (3 m) of your work area. Flying debris or a pinched body part will result in Death or Serious Injury.*

⚠ CAUTION *Be cautious when operating on un-level ground surfaces. A machine roll over could result in Minor or Serious Injury. Always wear your seat belt when operating this type of machinery.*

Before starting the skid steer engine with this splitter attached, make sure you are knowledgeable and comfortable with the operation of the auxiliary controls as outlined in the skid steer owner's manual.

Large wood pieces can be heavy. Some operators of the Conventional splitter will place a piece of wood under the unsupported end of the splitter to stabilize it.

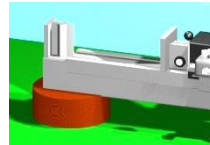

End support

Setup the conventional & horizontal model splitters on a flat level ground surface. The work surface you will be walking on should not have any ground depressions that would make working near the splitter unsafe.

⚠ CAUTION *When transporting the splitter, move slowly to avoid an accident that could result in Minor or Serious Injury.*

When transporting this attachment, always be aware of your surroundings.

While moving the splitter, pay attention to what obstacles or terrain are in front of the attachment and also in front and in back of the prime mover's wheels.

Splitter Cylinder Speed – The splitter's cylinder speed is regulated by the amount of hydraulic flow coming from the skid steer. The hydraulic flow can be regulated by the engine speed.

Use the skid steer loader lift to adjust the elevation of the splitter (up & down).

Starting the Job

⚠ WARNING *Never operate this attachment in an enclosed work area. Exhaust fumes could result in Death or Serious Injury. Work this attachment in an open air environment.*

⚠ WARNING *Moving or engaging the splitter with bystanders in the area could result in Death or Serious Injury. Before engaging the splitter hydraulics, always make sure the area is clear of bystanders.*

⚠ WARNING *Never reach across the splitter while the cylinder is extending or retracting. Pinching a body part could result in Death or Serious Injury.*

⚠ WARNING *Exposure to crystalline silica dust along with other hazardous dusts may cause serious or fatal respiratory disease. It is recommended to use dust suppression, dust collection and if necessary personal protective equipment during the operation of any attachment that may cause a high level of dust.*

1. Plan your worksite. Position your machine up-wind so that the heat and exhaust from the skid steer's engine will not enter your worksite.
2. Position your worksite on a level surface.
3. Operate the skid steer engine's speed from about one-quarter to one-half throttle. This will usually give you adequate cylinder speed.
4. Remind yourself and any co-workers to never to place hands, arms or other body parts near the push block when the cylinder is extending or retracting.
5. Before starting to split wood, always go over all the operational characteristics of your splitter with anyone working with you. Explain all the safety related items, and answer any questions they may have.

Log Splitting Tips

⚠ CAUTION *Never operate this attachment when bystanders are in proximity of the work area that could result in Minor or Serious Injury from flying debris or a moving skid steer.*

⚠ CAUTION *Use care when operating on uneven terrain or any type of sloped surface. Keep your attachment low to the ground when working in these conditions to avoid a roll over that could result in Minor or Serious Injury.*

1. Never load or reposition the log on the splitter while the push block is closing. Stop the push block movement by placing the control in neutral before repositioning the wood.
2. Keep your fingers and hands away from the cracks in the log as it is

being split. These cracks can sometime open and close causing an additional pinch point in the log.

3. Split log pieces that have square ends on them to avoid unwanted movement of the log during the splitting process.
4. Allow the split pieces to fall free from the splitter.
5. Don't attempt to split two logs at once. Only "bad" things can happen doing that!
6. After you have accumulated a pile of split wood on either side of the splitter, take a minute to clear the area so that a tripping hazard can be avoided.
7. Never attempt to cut a log against the grain. Always position the piece of wood with the cut ends between the push block and splitting wedge.

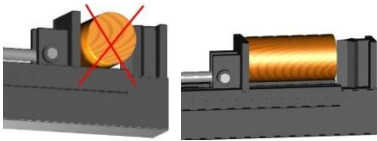

Split the Right Way!

8. If you must use your hand to steady a log on a Conventional or Horizontal models until the push block can hold the piece, always position your hand on top and in the middle of the log to be split, never near the ends. Remove your hand as soon as the push block starts trapping the log against the splitting wedge.
9. It is dangerous to operate the splitter control valve (Conventional model) while standing on the opposite side of the splitter from the valve. Operate the valve only from the left side of the attachment
10. Stop the travel of the push block any time you notice that the log is

slipping or could become dislodged from the attachment.

11. (Conventional model) Don't attempt to lift a log heavier than you can handle. Find another person to help lift or use a plank to roll the piece into position.
12. (Inverted model) Clear the area of all bystanders! While you are concentrating on splitting wood, do not forget to check around and behind the skid steer before turning or moving backwards.
13. (Horizontal model) While concentrating on the placement of the attachment over the log, always remember to pay attention to anyone entering into the danger zone around your entire machine.
14. (Inverted & Horizontal models) – It is possible to move logs and pieces around with the attachment. Gripe the log only tight enough to hold the log.

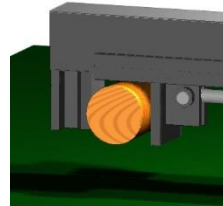

*Picking up logs
Inverted & Horizontal models*

Maintaining your Attachment

Modifications

Modifications to the original design by the end user may result in weakening the designed structure and integrity of this attachment and will void any warranty.

Before Every Use

NOTICE Always clean any

dirt from the hydraulic quick disconnects before connecting the splitter to the skid steer.

Contamination entering the hydraulic system could cause expensive repairs and downtime to the skid steer or splitter.

Check that all fasteners (nuts, bolts, pins, keepers) are in their right place and are tight.

Lubricate the push block (1 fitting) & channel using #2 lithium grease.

Inspect and replace any worn, torn or missing safety decals.

Investigate the location of any oil leaks and repair immediately.

Check the hydraulic oil level in the skid steer and add, if necessary.

After Every Use

Retract the cylinder to prevent oxidation of any exposed cylinder rod surface.

Inspect hydraulic connections for any leakage. Make repairs, if necessary.

Clean wood debris from push block slide channel.

Cover valve with lightweight plastic cover to shed any rain.

After Every Season

Clean sand & repaint any areas that contain worn off paint.

Store your implement in a shed or cover with a water-proof tarp to protect it from the weather.

Store in an area not frequented by children.



Hydraulic System

WARNING *A small stream of oil from a pinhole leak could penetrate your skin if contacted. To avoid an accident that could result in Death or Serious Injury, never use your hand or other body parts in an attempt to locate a hydraulic leak.*

NOTICE *Always release the hydraulic system pressure from the auxiliary circuit prior to removing the attachment or any hydraulic system service work.*

Be kind to the environment. Repair any hydraulic leaks immediately!

Hardware Torque

	Grade 2 lb-ft 	Grade 5 lb-ft 	Grade 8 lb-ft 
1/4"	66*	8	12
5/16"	10	17	20
3/8"	20	30	45
1/2"	45	75	110
3/4"	160	260	380

* = inch pounds

All values are "dry" torques.

Parts

When requiring any parts for your implement, please collect the following information:

Implement Model Number
Implement Serial Number
Parts Manual Date (lower right corner)
Parts Manual Page
Part Description
Quantity Required
Ship-to Name & Address
Payment Method

...then call your local dealer for factory fresh parts specifically designed for your attachment.

Conventional Log Splitter

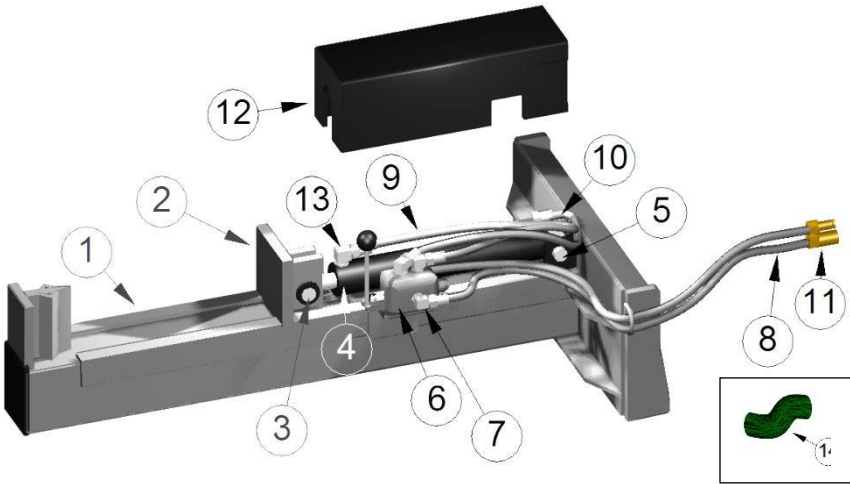

Ref.	Description	Qty.
1	Main Frame & Coupler Weldment	1
2	Push Block	1
3	Pin (Push Block to Cylinder Rod End)	1
4	Cylinder	1
5	Pin (Cylinder Base End to Frame)	1
6	Valve Assembly	1
7	90° Elbow (on Valve)	4
8	Hose Set (Valve to Quick Disconnect Couplers)	1
9	Hose (Valve to Rod End of Cylinder)	1
10	Hose (Valve to Base end of Cylinder)	1
11	Quick Disconnect Coupling Set	1
12	Cover (Over Cylinder)	1
13	90° Elbow (on Cylinder)	2
14	Sleeve (Hose Protection)	1

Inverted Log Splitter

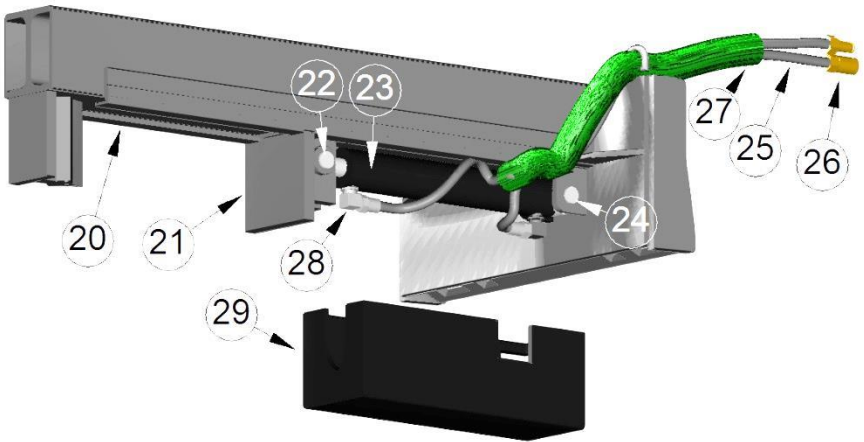

Ref.	Description	Qty.
20	Main Frame & Coupler Weldment	1
21	Push Block	1
22	Pin (Push Block to Cylinder Rod End)	1
23	Cylinder	1
24	Pin (Cylinder to Frame)	1
25	Hose Set (Cylinder to Quick Disconnect Couplers)	1
26	Quick Disconnect Coupling Set	1
27	Sleeve (Hose Protection)	1
28	90° Elbow on Cylinder	2
29	Cover (Over Cylinder)	1

Horizontal Log Splitter

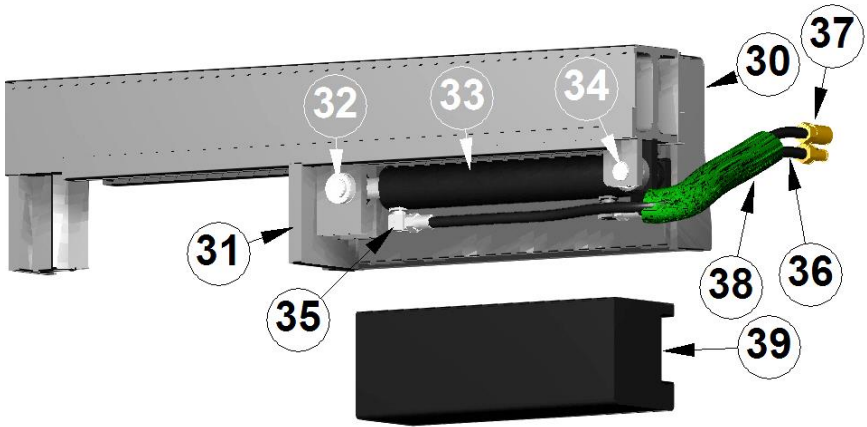

Ref.	Description	Qty.
30	Main Frame & Coupler Weldment	1
31	Push Block	1
32	Pin (Push Block to Cylinder Rod End)	1
33	Cylinder	1
34	Pin (Cylinder to Frame)	1
35	90° Elbow on Cylinder	2
36	Hose Set (Cylinder to Quick Disconnect Couplers)	1
37	Quick Disconnect Coupling Set	1
38	Sleeve (Hose Protection)	1
39	Cover (Over Cylinder)	1

Decals

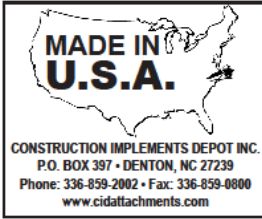
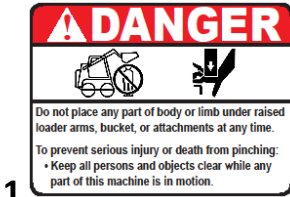

**Register your product at
www.CIDattachments.com**

For warranty information
call your dealer or go to
www.CIDattachments.com/CID_warranty.html

5



Ref.	Description	Qty.
1*	Decal, (Danger Pinch Points)	2
2*	Decal, (Warning, High Pressure Fluid Hazard)	1
3	Decal, Made in the USA	1
4	Decal, Construction Implements Depot	1
5	Decal, Registration & Warranty Info	1

*** WARNING** *Replace any worn, torn or missing safety decals before operating!*

Troubleshooting

Problem	Cause	Resolution
Cylinder does not move	Quick disconnect couplers not fully seated.	Reconnect quick disconnects.
	Push block channel clogged with wood debris	Turn off skid steer engine and clean out debris in push block channel. Apply light coat of lubricant in channel.
	No hydraulic flow	Check skid steer hydraulic system. Is Auxiliary activated?
	Hose obstruction	Inspect hoses between skid steer and attachment. Check for pinched spots that may be causing a lack of flow. Replace parts, if necessary.
	Failure in auxiliary circuit on skid steer	Investigate & repair
Skid steer hydraulic oil level goes down during operation	Leak between skid steer and attachment cylinder	Investigate & repair
	Leaks in skid steer hydraulic system	Investigate & repair
Splitter does not seem to have much power	Low system pressure	Have skid steer dealer check available pressure in the auxiliary circuit and repair.
	Push block channel clogged.	Turn off skid steer engine and clean out debris in push block channel. Apply light coat of lubricant in channel.

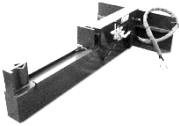
Specifications

Spec.	Model		
	Conventional	Inverted	Horizontal
			
Weight 20T/30T	847 lbs./986 lbs. (384 kg/447 kg)	815 lbs./954 lbs. (370 kg/433 kg)	815 lbs./954 lbs. (370 kg/433 kg)
Log Capacity Diameter	30" (762 mm)		
Max. Force	20 Ton Standard: 40,000 Lbf. (177929 N) 30 Ton Optional: 60,000 Lbf. (266893 N)		
Lube	1 - Fitting at Push Block		
SSL Aux. Hyd. GPM	7-25 GPM (26-94 L/min)		
Relief Setting	3000 PSI (207 bar)		
Warranty	12 months - See complete Warranty Statement for details		

Conventional Splitter Dimensions

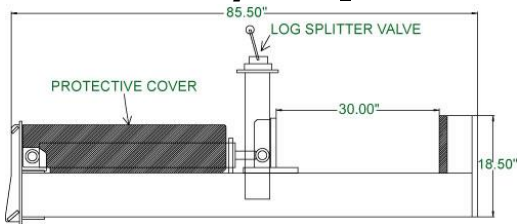

Inverted Splitter Dimensions

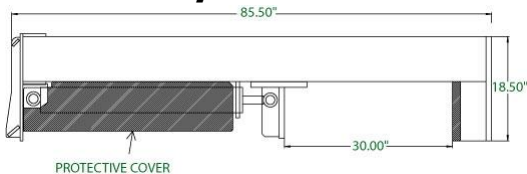

Horizontal Splitter Dimensions

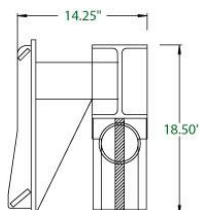

**Make
Every Day
A Safe Day!**



Owner's Manual

Log Splitters

Website

www.cidattachments.com

For More Information, Contact

sales@cidattachments.com

Phone: (336)859-2002

**1248 N. Main
PO Box 397
Denton, NC 27239**

Limited Warranty

Construction Implements Depot, Inc. products are warranted to be free from defects in workmanship or materials for period of (12) months from initial sale, lease or rental date.

Warranty Exclusions

This warranty does not cover normal wear items, including but not limited to, bearings, hoses, ground engaging parts such as, teeth, blades, cutting edges, pilot bits, auger teeth and broom bristles. This warranty does not cover maintenance, service or adjustments. This warranty does not cover damage due to misuse, negligence, accidents, or improper maintenance. This warranty does not cover damage due to improper application, installation, adjustment or setup. This warranty does not cover improper modifications of product. This warranty is void if any components have been disassembled, i.e. pumps, gear boxes, motors.

Specially modified attachments built by CID X-treme Attachments to meet your customer's needs shall not be warranted by Construction Implements Depot, Inc. This warranty does not cover replacement parts not supplied by CID, Inc.

Warranty Statement

Our obligation under this Limited Warranty shall be solely limited to repairing or replacing any part (see non-covered items) free of charge that, according to our judgment, show evidence of a defect in quality of workmanship or materials for the stated (12) month warranty period. All defective parts must be routed directly to CID, Inc. with freight or delivery charges to be prepaid. This Limited Warranty shall not be interpreted to render CID, Inc. liable for any injury or damage to persons, business or property of any kind nor expenses or losses incurred for labor, supplies, substitute machinery rental, or for any other reason. Repair or replacement parts are subject to the supply conditions at the time of repair or replacements, which may directly affect our ability to obtain material and/or replacements parts. CID, Inc. reserves the right to make improvements in design or changes in specifications at any time without incurring any obligations to owners of previously purchased units. No one but CID, Inc. is allowed to alter, modify or enlarge this warranty nor the exclusions, limitation and reservation at any time.