

ANTENNAS | OMNI-600-5G SERIES

OMNI-DIRECTIONAL, 2X2 MIMO 5G/4G ANTENNA

410 - 4200 MHz; 6dBi

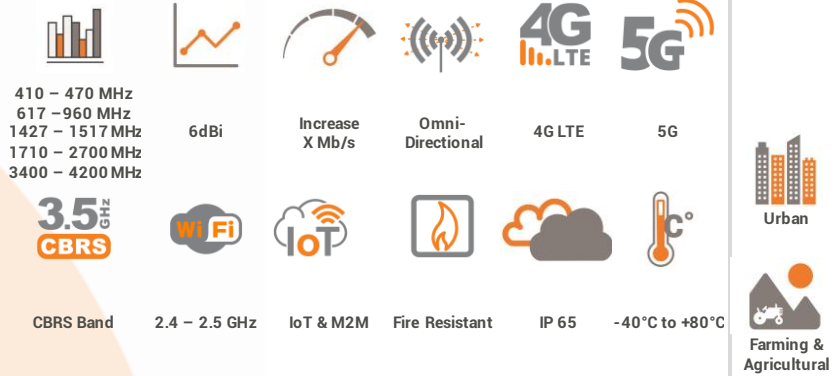

APPLICATION AREAS

- High-performance, wideband omni-directional antenna for FWA
- 2x2 MIMO capability for improved performance and throughput
- Consistent gain over a wide frequency band
- Ideal for FWA, M2M and IoT applications
- Dust and water-resistant enclosure with an IP65 rating

Product Overview

The OMNI-600-5G is an advanced antenna designed to meet the demands of modern 5G and 4G technologies. Covering a wide frequency range from 410 to 4200 MHz, this antenna ensures seamless connectivity across various bands, offering a peak gain of 5.8dBi for enhanced signal strength and reception. Its 2x2 MIMO configuration, achieved through vertically separated elements, maximizes data throughput and network efficiency while providing superior pattern control over the entire frequency spectrum. Engineered for compatibility with Carrier Aggregation (CA) and other advanced features, the OMNI-600-5G optimizes reception and throughput across multiple frequency bands simultaneously. Additionally, its coverage extending to the lower 450 MHz frequency band enables long-distance connectivity, making it ideal for diverse applications in urban, suburban, and remote environments.

In conclusion, the OMNI-600-5G is a high-performance antenna tailored to the specific requirements of 5G and 4G networks. With its ultra-wideband coverage, 2x2 MIMO capability, and superior pattern control, it ensures consistent and reliable connectivity in diverse operating conditions. Whether deployed in densely populated areas or remote regions, this antenna delivers unmatched performance, reliability, and throughput, making it an ideal solution for various applications requiring high-speed and long-range connectivity.

Features

- Ultra-wideband coverage from 410 to 4200 MHz
- Peak gain of 6dBi for enhanced signal strength and reception
- 2x2 MIMO configuration to maximize data throughput
- Superior pattern control for consistent signal coverage
- Dust and water-resistant with an IP65 rating

Application Areas

- Improve data transmission connection reliability & stability
- High-end industrial-grade router applications
- Areas with poor data signal reception
- 2.4 GHz Wi-Fi applications
- 3.3 to 4.2 GHz CBRS applications
- Mobile offices



OMNI-600-5G

Frequency Bands

The OMNI-600-5G is a cellular / IoT antenna that works from | 410 – 470 MHz | 617 – 960 MHz | 1427 – 1517 MHz | 1710 – 2700 MHz | and | 3400 – 4200 MHz |

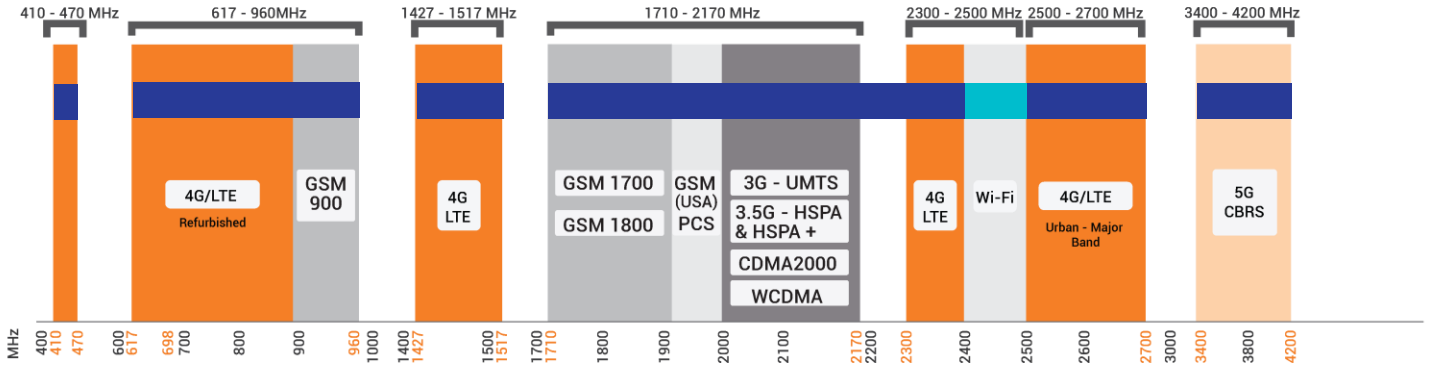

Indicates the 5G/LTE bands on which OMNI-600-5G works

Indicates the WI-FI bands on which OMNI-600-5G works

Antenna Overview

	
Ports	2
SISO / MIMO	2X2 MIMO
Frequency Bands	410 – 4200 MHz
Polarisation	Linear Vertical
Peak Gain	6 dBi
Coax Cable Type	Twin HDF 195
Coax Cable Length	5m
Connector Type	SMA (M)

**The coax cable & connector are factory mounted to the antenna*

Electrical Specifications

Frequency Bands:	410 – 470 MHz 617 – 960 MHz 1427 – 1517 MHz 1710 – 2700 MHz 3400 – 4200 MHz
Gain (Max):	-5 dBi @ 410 – 470 MHz 2 dBi @ 617 – 960 MHz 4 dBi @ 1427 – 1517 MHz 6 dBi @ 1710 – 2700 MHz 6 dBi @ 3400 – 4200 MHz
VSWR:	<3:1 Over 90% of the band
Feed Power Handling:	10 W
Input Impedance:	50 Ohm (nominal)
Coax Cable Loss:	0.250 dB/m @ 400 MHz 0.385 dB/m @ 900 MHz 0.507 dB/m @ 1500MHz 0.565 dB/m @ 1800 MHz 0.666 dB/m @ 2400 MHz 0.788 dB/m @ 3000 MHz
Polarisation:	Linear Vertical
DC Short:	Yes

Product Box Contents

Antenna:	A-OMNI-0600-V2-01
Mounting Bracket:	Pole up to 50mm diameter Wall and pole mount stainless steel bracket

Ordering Information

Commercial Name:	OMNI-600-5G
Order Product Code:	A-OMNI-0600-V2-01
EAN Number:	6009710927854

Mechanical Specifications

Product Dimensions	646 mm x Ø71 mm excluding bracket
Packaged Dimensions:	700 mm x 150 mm x 100 mm
Weight:	0.8 kg
Packaged Weight:	1.64 kg
Radome Material:	ABS (Halogen Free)
Radome Colour:	Pantone – Cool Gray (1C) RAL -7047
Mounting Type:	Wall/Pole mount

Environmental Specifications, Certification & Approvals

Antenna Wind Survival:	≤160 km/h
Temperature Range (Operating):	-40°C to +80°C
Environmental Conditions:	Outdoor/Indoor
Ingress Protection:	IP 65
Salt Spray:	MIL-STD 810G/ASTM B117
Operating Relative Humidity:	Up to 98%
Storage Humidity:	5% to 95% - non-condensing
Storage Temperature:	-40°C to +80°C
Enclosure Flammability Rating:	UL 94-HB
Impact Resistance:	IK 08
Product Safety & Environmental:	Complies with CE and RoHS standards



Antenna Performance Plots

VSWR

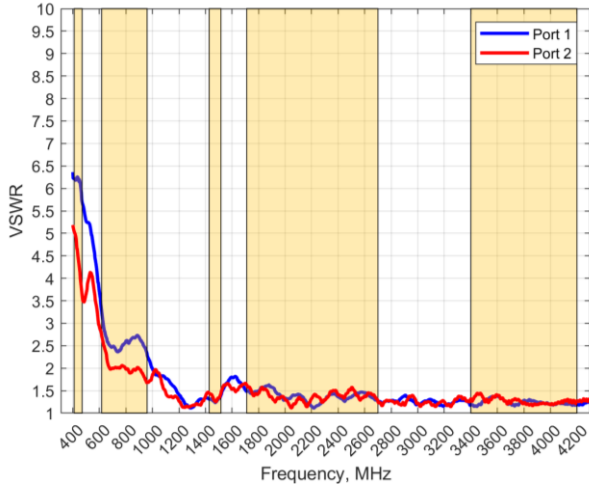

Voltage Standing Wave Ratio (VSWR)*

VSWR is a measure of how efficiently radio-frequency power is transmitted from a power source, through a transmission line, into a load. In an ideal system, 100% of the energy is transmitted which corresponds to a VSWR of 1:1.

The OMNI-600-5G delivers superior performance across all bands with a VSWR of <3:1 over 90% of the band.

*VSWR measured with a 2m low loss cable

GAIN (EXCLUDING CABLE LOSS)

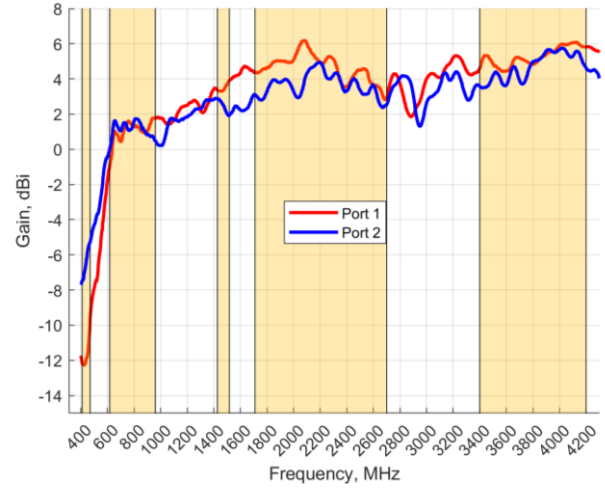

Gain* in dBi

6 dBi is the peak gain across all bands from 410 – 4200 MHz

Gain @ 410 – 470 MHz:	-5 dBi
Gain @ 617 – 960 MHz:	2 dBi
Gain @ 1427 – 1517 MHz:	4 dBi
Gain @ 1710 – 2700 MHz:	6 dBi
Gain @ 3400 – 4200 MHz:	6 dBi

*Antenna gain measured with polarisation aligned standard antenna

Radiation Patterns

Azimuth: 410 – 470 MHz

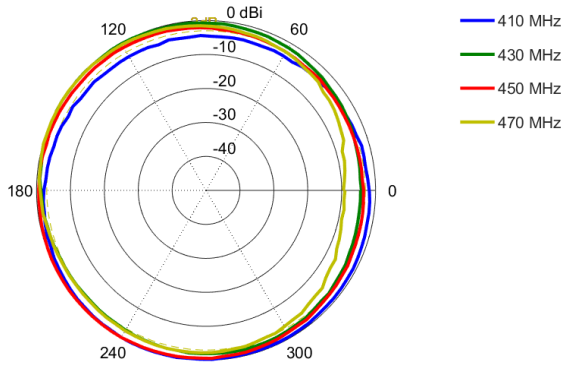

Elevation: 410 – 470 MHz

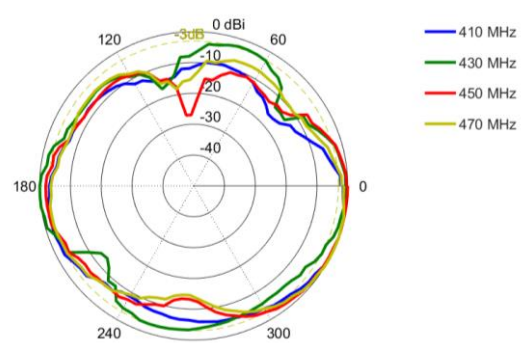

Azimuth: 617 - 960 MHz

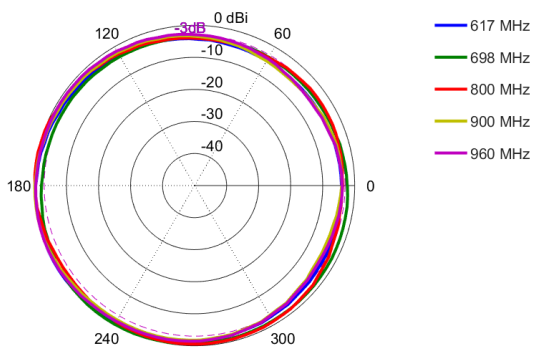

Elevation: 617 - 960MHz

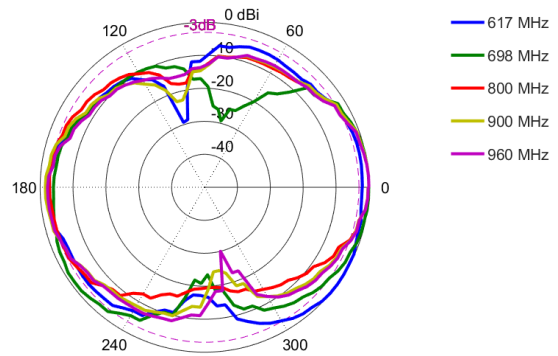

Azimuth: 1427 - 1517 MHz

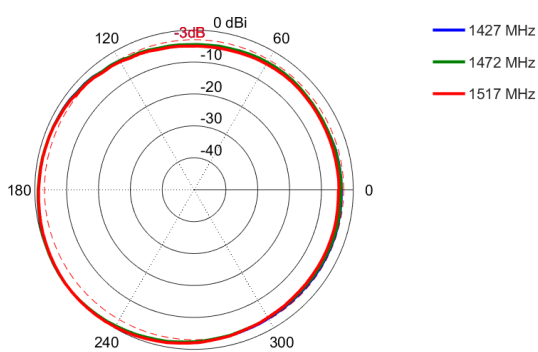

Elevation: 1427 -1517 MHz

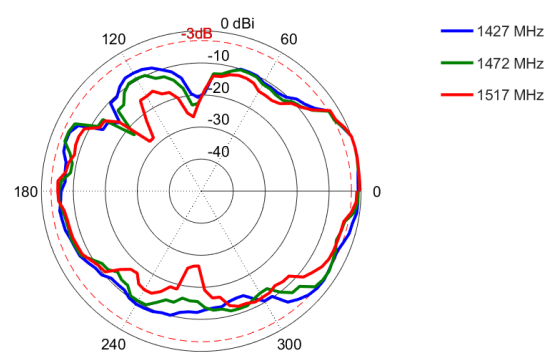

Azimuth: 1710 - 2100 MHz

Elevation: 1710 - 2100 MHz

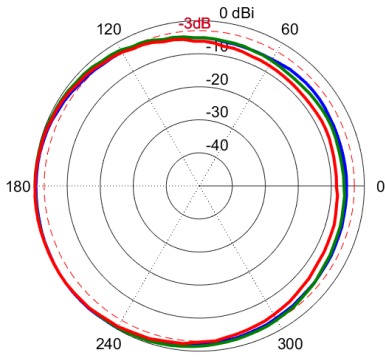

- 1710 MHz
- 1900 MHz
- 2100 MHz

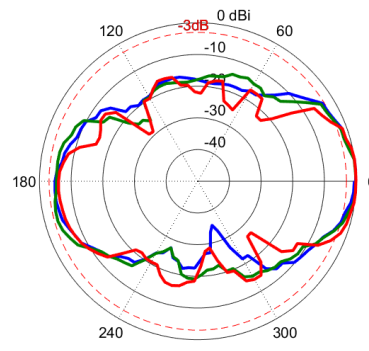

- 1710 MHz
- 1900 MHz
- 2100 MHz

Azimuth: 2300 - 2700 MHz

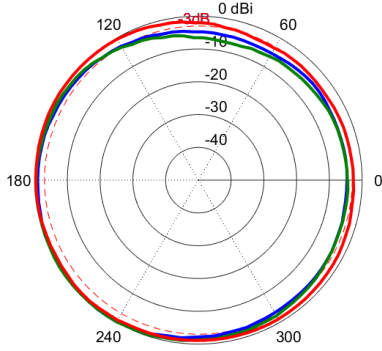

- 2300 MHz
- 2500 MHz
- 2700 MHz

Elevation: 2300 - 2700 MHz

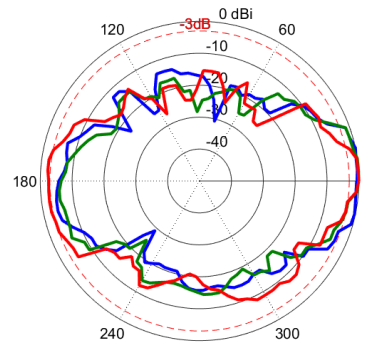

- 2300 MHz
- 2500 MHz
- 2700 MHz

Azimuth: 3400 - 4200 MHz

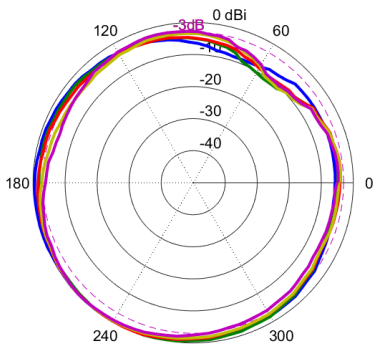

- 3400 MHz
- 3600 MHz
- 3800 MHz
- 4000 MHz
- 4200 MHz

Elevation: 3400 - 4200 MHz

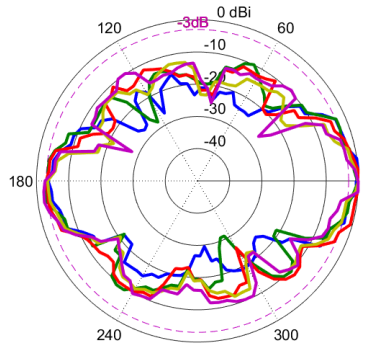

- 3400 MHz
- 3600 MHz
- 3800 MHz
- 4000 MHz
- 4200 MHz

Technical Drawings

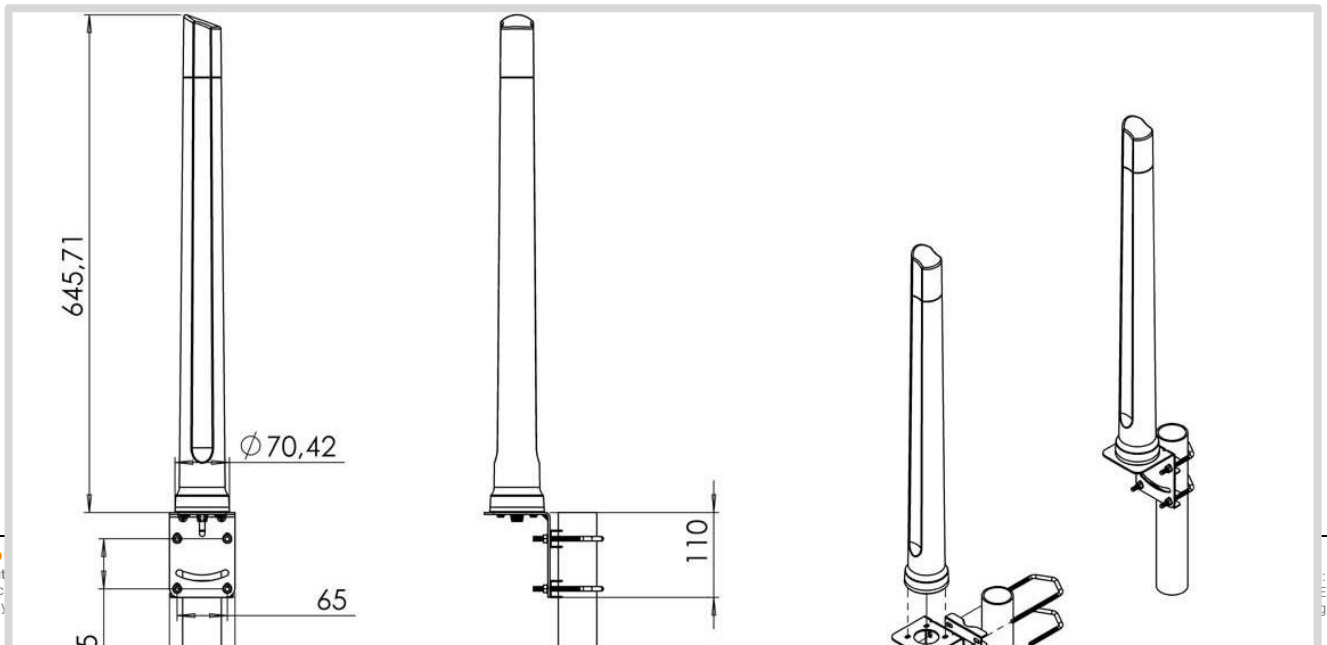

Mounting Options

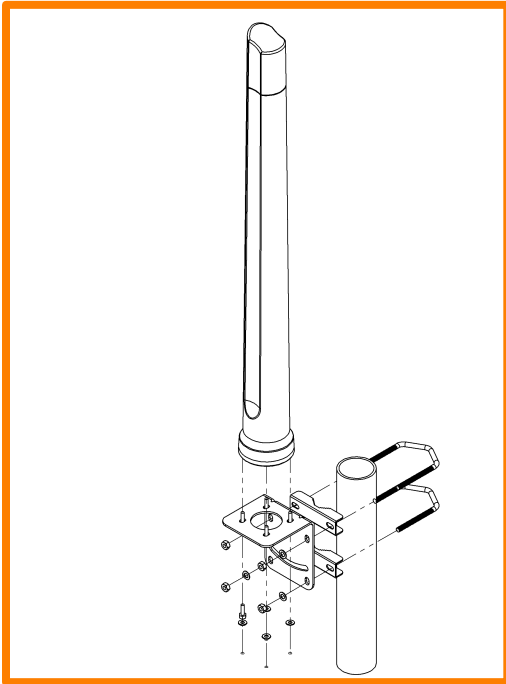

Pole Mount

Wall/pole mount bracket included

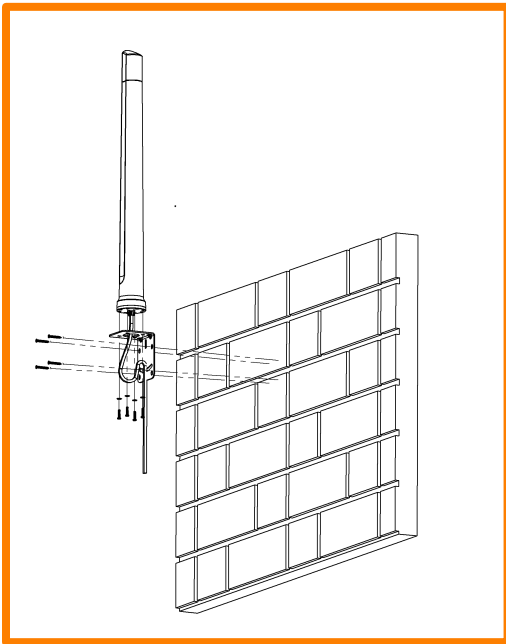

Wall Mount

Wall/pole mount bracket included

Additional Accessories

Extension Cables: Up to 15m HDF 195
Various connectors available
Installation poles and brackets available

See accessories technical specifications on www.poynting.tech

CONTACT POYNTING

Poynting Antennas (Pty) Ltd - Head Office

Unit 4, N1 Industrial Park,
Landmarks Avenue,
Samrand, 0157, South Africa

Phone: +27 (0) 12 657 0050

E-mail: info@poynting.tech

International Email: sales-global@poynting.tech

Poynting Europe

Regus Business Center Neue Messe Riem
Kronstadter Straße 4
81677 München
Germany

Phone: +49 89 7453 9002

E-mail: sales-europe@poynting.tech

Poynting USA

1804 Owen Court, Suite 104,
Mansfield,
TX 76063
USA

Phone: +1 817 533-8130

E-mail: sales-us@poynting.tech