

User Guide

Global Payments FLEX

Semi-integrated – T650P

Pay-At-The-Door (PATD)

A smart terminal that puts convenience and security at your fingertips



Table of contents

Table of contents	2		
Introduction	3		
General tips	3		
Available hardware	4		
Basic terminal operations	4		
Before you begin	4		
Unpacking the Box	5		
Terminal placement	5		
Connecting to power	5		
Terminal ON/OFF/REBOOT	6		
Power ON your device	6		
Power OFF your device	6		
REBOOT your device	6		
Changing the terminal language	7		
Main interfaces	7		
Home screen	7		
Android all apps page	7		
Flex main page	7		
Buttons and keypads	8		
Android buttons on the device	8		
Virtual keypad in the Payments app	8		
Virtual keypad	9		
Numeric data entry	9		
Alphanumeric data entry	9		
Header and condition icons	10		
Wi-Fi and 4G	10		
Battery management	10		
Key beep and display	11		
Key beep	11		
Display	11		
Brightness level	11		
Ambient display (Wake up motion)	11		
User access management	11		
Manager password	11		
		Change your manager passwords	12
		Network communication	12
		Set up Wi-Fi network connectivity	12
		Set up T650P to ECR/POS connectivity	13
		Set up 4G mobile data connectivity (T650P only)	13
		Accepting payment cards	13
		Contactless	13
		EMV chip card	14
		Magnetic stripe	14
		Launcher application	15
		Sale transaction	15
		Refund	17
		Void	17
		Phone Order	18
		Synchronization	19
		Performing an End Of Day (settlement)	19
		Reprint	19
		Reports	20
		Remote update	20
		Replacing the paper roll	20
		T650P	20
		Troubleshooting	21
		Card reader does not work properly (“Cards are Not Read”)	21
		Terminal does not work properly	21
		Receipt paper is jammed	22
		Receipt is blank	22
		POS Comm error	22
		Cleaning	22
		Service and support	22
		Returning a terminal for service	22

Introduction

Global Payments offers your business a wide variety of leading payment technology solutions, all from one reliable source. As one of the world's largest and most trusted payment technology solution providers, Global Payments combines industry-leading expertise with over 50 years of Canadian-specific experience. This powerful combination allows us to deliver comprehensive solutions that are personalized to your needs.

This guide is your primary source of information for operating, setting up, and installing the Global Payments Terminal. For terminal-related questions or support, please contact Global Payments' Customer Care.

General tips

To help ensure a smooth processing experience with Global Payments Canada, please consider the following tips:

1. **User guide:** Make sure to keep this user guide in an easily accessible location. It contains valuable information about your terminal's features, functions, and basic troubleshooting techniques.
2. **Daily settlement:** It is recommended to perform a daily settlement. This practice ensures that your funds are deposited into your bank account on a regular basis, providing you with timely access to your funds.
3. **Password security:** To protect yourself from unauthorized use of your terminal, it is essential to change your passwords frequently. Regularly updating your passwords enhances the security of your terminal and helps safeguard your account information. To set up your personalized manager password, kindly reach out to Global Payments Customer Care Centre at **1.888.682.3309**. Please note that the password should consist of 7-12 characters or digits.
4. **Troubleshooting:** If you encounter any issues with your terminal, start by checking the cabling connections and attempt to reboot the device. Oftentimes, this simple troubleshooting step can resolve common problems and restore normal functionality.
5. **Communication problems:** In case of communication issues with your terminal, first verify that there are no reported outages from your Internet or wireless service provider. This step helps rule out external factors that may be causing the problem.
6. **Customer service support:** Remember that Global Payments Canada offers a dedicated Customer Service line. Whenever you need assistance or encounter difficulties, reach out to their support team. They are available to provide prompt assistance and ensure that you receive the help you need.

Available hardware

Global Payments offers a variety of terminal options to cater to different needs. This guide is tailored specifically for the Verifone **T650P 4G wireless** device for FLEX Pay At The Door (PATD) mode.



T650P 4G wireless device



Optional charging base (T650P only)

Basic terminal operations

Before you begin

Global Payments Terminal is a point-of-sale electronic payment terminal designed to process debit and credit card transactions via Wi-Fi wireless network, ethernet, and/or cellular 4G wireless network.

FLEX Pay At The Door (PATD) via the T650P 4G supports TCP/IP (Wi-Fi) and 4G.

CAUTION:

For safety purposes, it is important to avoid using the terminal in proximity to water sources such as wet basements, bathtubs, washbowls, kitchen sinks, laundry tubs, or swimming pools. This precaution helps minimize the risk of electrical shock or terminal damage. Additionally, the terminal should not be utilized in environments with flammable substances or conditions to prevent any potential hazards.

Unpacking the Box

Upon receiving the shipment, carefully inspect the shipping carton and its contents for any signs of damage that may have occurred during transit. If you discover any damage, it is crucial to take immediate action. File a claim with the shipping company and promptly notify Global Payments about the situation. Under no circumstances should you attempt to use any equipment that appears to be damaged.

Next, proceed to unpack the items from the carton. Based on your order, you should find the following items included:

- T650P
- A SIM card installed (exclusive to the 4G mobile data terminals)
- An external power supply
- A quick start guide
- An optional (\$) wireless charging base (exclusive to the T650P model)
- A roll of thermal printer paper

By carefully inspecting and unpacking the items as instructed, you can ensure that you have received the correct equipment and are ready to proceed with setting up your Global Payments Terminal.

Terminal placement

To optimize the performance and longevity of your terminal, we recommend carefully selecting its placement. Ideally, position the terminal near a power outlet and, if applicable, an ethernet port. The location should be easily accessible to the user(s) and provide sufficient ventilation and protection.

However, it is important to avoid placing the terminal in areas with specific conditions that may adversely affect its operation. Avoid high-temperature environments, excessive vibrations, dusty surroundings, damp areas, and proximity to sources of electromagnetic radiation such as computer screens, microwave ovens, or anti-theft barriers.

To prevent accidental damage, ensure that all cables and power cords are securely fastened.

The terminal is designed to function within the following environmental specifications:

- Operating temperature range: 0°C to 45°C
- Operating relative humidity range: 10% to 95% RH (non-condensing)
- Non-operating temperature range: -20°C to +70°C
- Non-operating relative humidity range: 5% to 95% RH (non-condensing)

By adhering to these guidelines, you can maintain the optimal operating conditions for your terminal, ensuring its reliability and performance.

Connecting to power

Place the terminal and the optional base on a flat surface, plug the power supply into a surge protector attached to an electrical outlet.

CAUTION:

Use only the DC power supply that was shipped with your unit. Using a power supply with incorrect voltage and amps can result in device damage and will void your device's warranty.

Here are the power supply specification for the T650P models:

T650P power supply	DC	5V/2A
	Battery	2600mAh/7.2V Li-Ion rechargeable battery
	The mobile terminal's status bar displays a thunderbolt icon  when connected to a wired power supply or base, indicating external power and battery charge level. The battery starts charging below the default threshold of 90% capacity.	

CAUTION:

When the battery level drops to 15% or less, the **“battery warning notification icon”** will display on the left of the top bar.



When the battery level drops to 15% (critical level), **all functions will no longer work.**

Terminal ON/OFF/REBOOT

The terminal power configuration differs across devices; view the table below to see the power connectivity method for your device(s):

Wireless—T650P

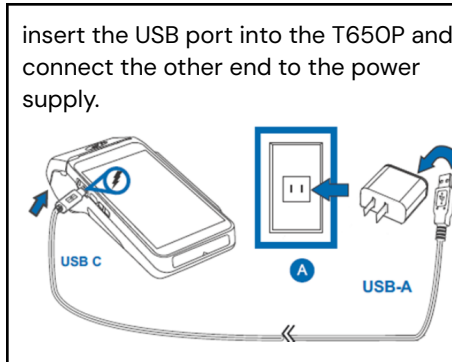

The **T650P** comes pre-charged, but we advise you to charge the terminal to ensure it maintains a battery life above 15% for seamless transaction processing. Inside the box, you will find the power cable. To charge the device,





Power ON your device

1. Ensure your terminal matches one of the following criteria:
 - Fully charged
 - Has at least 20% battery left
 - Plugged into a power source or
 - Placed on a charging base or a communication base.
2. Press and hold the **power button** [] until a logo is displayed, then release the power button; the terminal will boot up and then enter the Unified Payments application screen.

Power OFF your device

1. Press and hold the **power button** [] to wake the device up.
2. Press and hold the **power button** [] until the user menu is displayed, press [**Power off**].

REBOOT your device

1. Press and hold the **power button** [] to wake the device up.
2. Press and hold the **power button** [] from the left side of the device until the user menu is displayed, press [**Restart**].

Changing the terminal language

The terminal language configuration is initially set up based on your preferences with Global Payments. If you need to change the terminal language settings, please reach out to Global Payments' Customer Care at **1.888.682.3309** for assistance.

Main interfaces

There are three(3) main interfaces within your Global Payments Terminal.



Home screen

Welcome to the home screen of your device. To access additional features and settings, simply tap or swipe up from the [] symbol located on the home screen. This action will open the **Android all apps page**, where you can find various options such as the Payment app, Wi-Fi connectivity settings, sound settings, brightness adjustments, battery management, and more.



Android all apps page

This page showcases all the **pre-installed applications** on your device. The available apps may vary depending on your device setup.

To access this page, simply tap the [] Android home button located at the bottom of the terminal. From the home screen, tap the [] symbol to open this page, where you can find and access the various pre-installed applications.

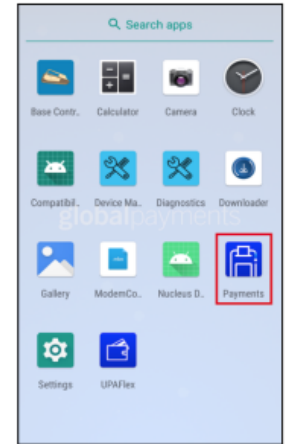

Flex main page

The **Unified Payments Application Flex**, also known as the "Flex" in this user guide, serves as your central hub for managing your daily payment requirements. With features such as sales, refunds, close batch, reporting, and more, it provides a comprehensive solution for your payment needs.

Typically, the **Flex** should launch automatically when you power up your terminal, ensuring easy access right from the start.

Alternatively, you can manually open the **Payments app** by locating and tapping the blue Payments app icon on the

Payments app main interface:

Pay at the Door

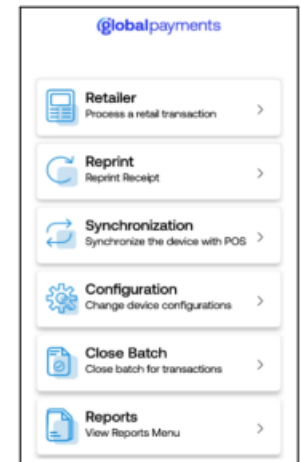

"**Android all apps page**" This allows you to quickly access the Flex app and begin utilizing its functionality. The **Flex app** is launched by opening the **Payments app**. **DO NOT open the Flex app.**

Payments app icon:



Flex app icon:

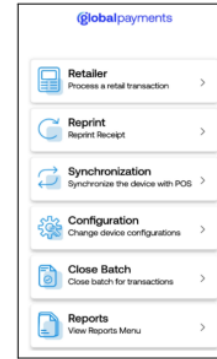



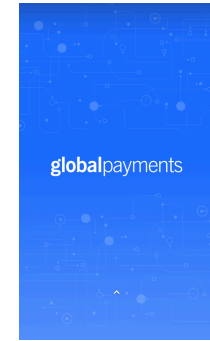

Flex (PATD) app main page



Home screen









Buttons and keypads



Android buttons on the device

Soft buttons	Function	Action
	Android back button	Once tapped, the app will be forced to close itself then the device will go back to whatever app or action you have before that.
	Android home button	Once tapped, it will automatically bring you to your launcher's "Home page" (Android home page).
	Android search button	Once tapped, it will display all of the previous apps that you have opened and will be listed on a little window view.
	Home screen button	Once tapped, it will launch the Android app page.

All of the soft buttons are located on the bottom of your screen. See examples below:

Virtual keypad in the Payments app

Buttons	Functions
	1
	2
	3
	4
	5
	6
	7
	8
	9

	0
	Correct Key. Pressing this equals backspace, clearing one character at a time
	Blue Enter key. Pressing this will submit the data entered

Virtual keypad

Global Payments Terminal has a virtual keyboard keypad on a 5.5" Colour TFTLCD with Capacitive Touch Panel (1280 x 720 pixels) which can be used with a finger. The samples of the virtual numeric keypad and QWERTY keyboards shown below will display when the field tapped on the touch screen requires alpha and numeric entry.

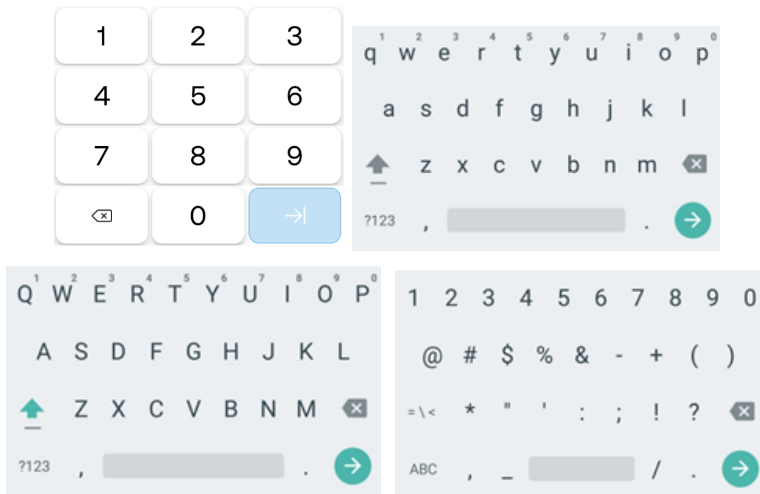

Numeric data entry

The terminal keypad will automatically default to a numeric-only keypad when entering data into numeric-only fields, such as card number and amount prompts. See the following examples:

The card number is a numeric data item. To enter the value "544619999," press [5], [4], [4], [6], [1], [9], [9], [9], and [9] on the android keypad. Then press [→] to confirm the data entered. The terminal then starts validation.

For amount entries, the terminal initially displays \$0.00. For example, to enter the value "\$5.30," press [5], [3] and [0]. No decimal point is entered.

Then tap [] to confirm the data entered. The terminal then starts validation.

Alphanumeric data entry

When a field allows for alphanumeric entry, the virtual Android keyboard is displayed.

Lower case entry keyboard is displayed on the right

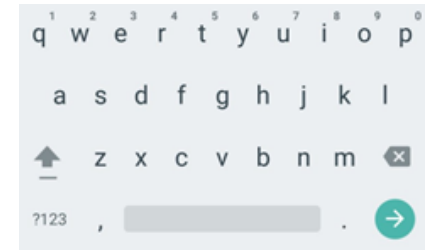

Press  on the lower case keyboard, the uppercase entry keyboard is displayed

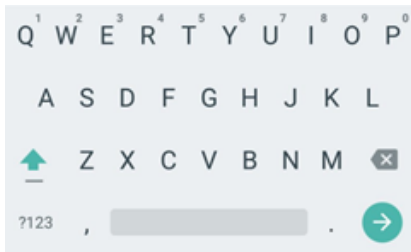

Press [**?123**] on the alphabet keyboard, the numeric and symbol entry displayed

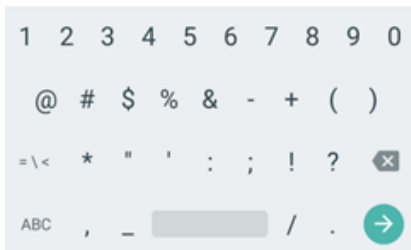

Power/Battery and Time icons are aligned to the furthest right:

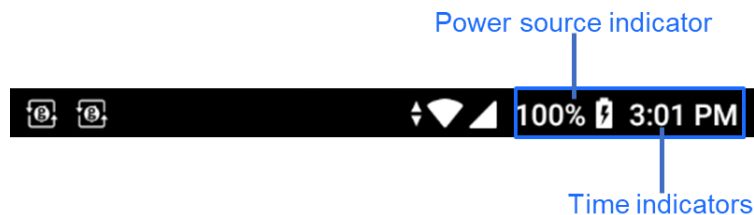

Header and condition icons

The system supports graphical icons that will indicate conditions the terminal may be in at various states. The condition icons are displayed in the header of all the screens. They indicate the status of the terminal and application and you about conditions that may prevent normal operation.

Connectivity icons are aligned to the right:

Wi-Fi and 4G



*4G not supported

Battery management

Swipe down from the top of the screen. When you see the status bar, **tap**  to access **Settings**. Tap **Battery**.

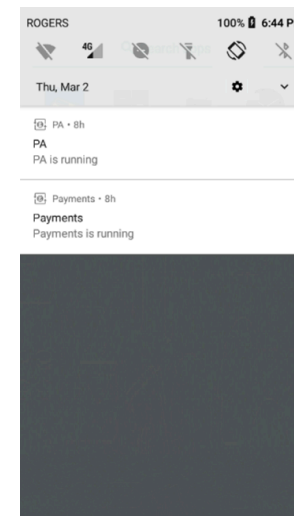

You will be directed to the battery management page.

You can view and monitor your terminal's battery usage on this page.

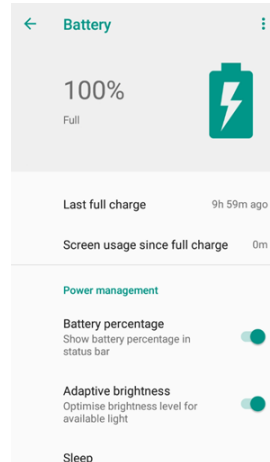

Ambient display (Wake up motion)

1. Swipe down from the top of the screen. When you see the status bar, **tap** [⚙️] to access Settings.
2. Tap **Display**.
3. Tap **Advanced**.
4. Gesture down to **Ambient display**.
5. Toggle to **[On]**.

Key beep and display

Key beep

To enable or disable key beep, please contact Global Payments Customer Care Centre at **1.888.682.3309**.

Display

Follow the instructions below to configure brightness level and ambient display.

Brightness level

1. Swipe down from the top of the screen.
2. Slide the **wrench** right to left to adjust the brightness.

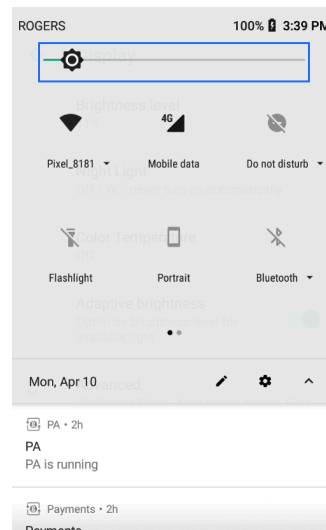

User access management

For **Flex** app, the Manager password is used to access Configuration menu and use for any password protected functions

NOTE:

To set up your personalized manager password for the first time, kindly reach out to Global Payments Customer Care Centre at **1.888.682.3309**. Please note that the password should consist of 7-12 alphanumeric characters or digits.



Manager password

To set up manager password, navigate to the Password menu located within the **Configuration menu** of the Global Payments Terminal T650P.

NOTE:

Choose a password that consists of 7-12 alphanumeric characters. This ensures a balance between security and ease of use.

Change your manager passwords

1. Tap **Configuration** on the Flex Payments app home screen.
2. Enter Manager password
3. Tap Other Parameters.
4. Tap **Password**
5. Tap **Manager Password**.
6. Tap [] to delete the pre-programmed default password that is masked.
7. Enter **Password**.
8. Tap [].
9. Terminal prompts: **SAVE THIS PARAMETER?** Tap **No** or **Yes**.
10. Tap **Yes** to return to the Password menu screen.
11. Tap [] to return to the Flex app home screen.

Network communication

The Global Payments Terminal offers different communication options based on the model. For Flex Pay At The Door (PATD) mode, the T650P supports TCP/IP (Wi-Fi) and 4G connectivity.

Network configuration for Pay-At-The-Table (PATT) on the T650P is TCP/IP (Wi-Fi) only:

Network	ECR/POS - T650P	T650P - Host
Available connectivity mode	TCP/IP (Wi-Fi)	4G

To set up your device connectivity, follow the steps below..

Set up Wi-Fi network connectivity

To set up Wi-Fi connectivity on your device, follow these steps:

1. Swipe down from the top of the home screen. Once the status bar appears, swipe down again.
2. Tap the Wi-Fi icon to enable Wi-Fi.
3. To view available networks, tap the arrow located at the bottom of the Wi-Fi icon.
4. From the list of available networks, select the SSID name of the Wi-Fi network you wish to connect to.
5. Enter the Wi-Fi password for the selected network.
6. Finally, tap [**CONNECT**] to establish the Wi-Fi connection.

NOTE:

Wi-Fi signal range typically covers an area of approximately 100 feet in diameter in an open area. Ensure that you are within the range of the Wi-Fi network for a stable and reliable connection.

Set up T650P to ECR/POS connectivity

To set up TCP/IP (Wi-Fi) connectivity between the T650P to ECR/POS, follow these steps:

1. Obtain the ECR/POS IP address
2. From the Flex app home screen, Tap **Configuration**
3. Enter Manager Password
4. Tap **Connection Configuration**
5. Tap **Configuration**
6. Tap **IP**
7. Launch keypad by pressing the screen
8. Enter IP address, Tap Confirm
9. IP Port (Defaulted as 2200), Tap Confirm

NOTE:

IP address will return to default when download is performed. The above Set up TCP650P to ECR/POS connectivity steps will have to be performed.

Set up 4G mobile data connectivity (T650P only)

The Global Payments Terminal T650P model is equipped with 4G wireless capability, automatically selecting the best available network. If you have ordered a 4G configuration, rest assured that Global Payments will handle the insertion and programming of the network SIM Card for your terminal prior to shipment. **No setup is required on your part.**

Upon powering up the terminal, it will automatically connect to the mobile data network. Please note that the connection time may vary depending on the signal strength in your area. You can verify the mobile data network

connection by checking the top right corner of the terminal screen, where the **Mobile Data network icon** will be displayed. Once connected, the icon will be filled up. If the icon remains empty or if there is no SIM card symbol, it means that the mobile data network is not connected.



To ensure uninterrupted transaction processing, always ensure that the terminal is connected to the mobile data network before initiating any transactions.

Accepting payment cards

Contactless

To perform a contactless transaction using your terminal, follow these steps:

1. Launch the Payments app by tapping the transaction icon on the home screen.
2. Follow the on-screen prompts provided by the app.
3. Firmly bring your card up to the active zone located above the display. Hold it approximately 1 cm above the contactless logo on the paper trapdoor.
4. During the transaction, keep the card in close proximity to the display.
5. Your contactless terminal features a row of four status indicators visible on the screen. When you initiate a contactless transaction, the



first (left-hand) status light will turn green, indicating that the contactless display is active but no card is being read yet.

- When you present a contactless card to the active zone during the transaction, the second, third, and fourth status indicators will turn green. A successful card read is indicated when all four status indicators are displayed in green, accompanied by an audible confirmation tone.

EMV chip card

To perform an EMV chip card transaction using your terminal, follow these steps:

- Launch the **Payments app** by tapping the transaction icon on the home screen.
- Follow the prompts displayed on the screen as instructed.
- Ensure the chip side of the card is facing upward.
- Position the chip card in the smart card reader slot, following the indicated orientation.
- Insert the chip card smoothly and continuously into the slot until it securely seats.
- Wait for the transaction to complete, as indicated on the screen.
- Only remove the card from the terminal once the screen confirms that the transaction is complete.



CAUTION:

Leave the chip card in the reader until the transaction is complete. Premature card removal will invalidate the transaction.

Magnetic stripe

To perform a magnetic stripe transaction using your terminal, follow these steps:

- Launch the **Payments app** by tapping the transaction icon on the home screen.
- Follow the prompts displayed on the screen as instructed.
- Position the magnetic stripe card with the stripe facing inward, toward the keypad. Insert the card from the top of the unit to ensure a proper read of the magnetic stripe card.
- Swipe the card smoothly and steadily through the magnetic card reader.
- Wait for the screen to indicate that the transaction is complete.
- Once the transaction is confirmed, proceed as instructed for any further actions.



Launcher application

The Launcher Application is a secure, restricted environment designed to function as the default home screen launcher on a device. In this mode, only approved Payments and Downloader applications can be accessed, ensuring that users interact solely with the intended functions of the device.

NOTE:

Please contact Global Payments Help Desk to disable the Launcher application if you would like to remove this application.

You may access Android settings to Network etc.

To access the Android settings:







1. Go to **Configuration** menu
2. Tap **Exit Application**
3. You will be taken to the Launcher application home screen
4. On the screen, use gesture and tap on the screen: Down (bottom of the screen), Down (bottom of the screen), Left (side of the screen), Right (side of the screen), Left (side of the screen), Right (side of the screen).
5. You will now be at the Android settings menu

To go back to the FLEX app:

1. Press the **Back**  button on the bottom right of the Terminal.
2. At the Launcher home screen, tap **Payment**

Sale transaction

Use the sale transaction function to start accepting payments from your customers.

1. For Pay-At-The-Door, transactions are first entered in the ECR/POS system. Then the T65OP will be carried out to the delivery location, and the T65OP will not be communicating with the ECR/POS when the customer is ready to pay:
2. At the T65OP. On the Flex main menu, tap **Retailer**.
3. Tap **Sale**
4. Enter the clerk # and tap []
5. Enter the invoice # and tap []. The invoice # must be 1-16 digits.
6. Enter the amount then tap the []
7. Enter the tip amount then tap []
8. Hand the device to the customer, then tap [].
9. If the tip function is enabled, the cardholder can select one of the following options :
 - a. **[Select one of the three pre-set tip percentage options or No Tip displayed on the screen]**, proceed to the next step.
 - b. **[Other]**, the cardholder enters the dollar amount for the tip then proceeds to the next step.
 - c. [], located at the top right corner, the application will go back to the **Flex** app main menu.
10. The cardholder taps [] to confirm the total amount.

11. Terminal displays “**the Normal Card Entry Screen – insert, tap, swipe, or for manual entry, press the [Other Payment Options]** then select **[Manual Entry]**”.
12. The cardholder may choose to tap, insert, or swipe their card to make a payment.
13. The terminal communicates with Global Payments and starts the processing. Proceed to step 14 upon completion.
14. Transaction complete, select one of the following options:
 - **[Paper]**, the merchant copy of the receipt is printed first, then followed by the customer receipt.
 - **[No Receipt]**, the merchant copy of the receipt is printed and no customer copy of receipt will be printed.

TIPS:

- If the terminal fails to read the credit card using the contactless, chip, and magnetic stripe methods, ask for another form of payment.
- If a debit card cannot be read, you must ask for another form of payment. Debit cards cannot be entered manually or swiped.
- Synchronization is required once the T650P is back at the ECR/POS location.





Refund

Use the refund transaction to credit your customer.

IMPORTANT:

Upon receiving your terminal, please note that this function is initially deactivated. To activate it, you must establish your unique manager password during the initial setup. To acquire your manager password, kindly reach out to the Global Payments Customer Care Centre at **1.888.682.3309**.

Remember that your password must be a combination of 7-12 alphanumeric characters or digits.

1. Go to the Flex app. On the main menu, select Retailer.
2. Tap **Refund**
3. Enter the clerk # and tap []
4. Enter the invoice # and tap [].
5. Enter manager password and tap [].
6. Terminal displays “**the Normal Card Entry Screen – insert, tap, swipe, or for manual entry, press the [Other Payment Options]**” then select [**Manual Entry**]”.
7. For credit card refunds, the cardholder Taps/Inserts or swipes their card, then proceeds to step 9.
8. For debit card refunds, the cardholder must be present. The cardholder taps/inserts or swipes their card. For insert cards, the cardholder selects [**CHEQUING**] or [**SAVINGS**]. Please note that debit card transactions cannot be manually entered.
9. The cardholder enters PIN, tap []. The terminal displays “**PIN OK**”.

10. Transaction complete, select one of the following options:

- [**Paper**], the merchant copy of the receipt is printed first, then followed by the customer receipt.
- [**No Receipt**], the merchant copy of the receipt is printed and no customer copy of receipt will be printed.

TIPS:

- Transaction password protection is highly recommended for return transactions.
- Synchronization is required when the T650P returns to the ECR/POS.

Void

IMPORTANT:

Upon receiving your terminal, please note that this function is initially deactivated. To activate it, you must establish your unique manager password during the initial setup. To acquire your manager password, kindly reach out to the Global Payments Customer Care Centre at **1.888.682.3309**.

Remember that your password must be a combination of 7-12 alphanumeric characters or digits.

If you have entered the wrong amount or need to cancel a transaction, use the **Void** transaction (instead of **Refund**) wherever possible. Transactions that are voided will not appear on the cardholder statements.

Transactions can only be voided before they are settled:

1. Go to the Flex app. On the main menu, select **Retailer**.
2. Tap **Void**
3. Enter manager password and tap [→]
4. Enter clerk # and tap [→]
5. Select a transaction from the list or use the **Search** field.
6. Verify the information, then tap the []
7. Wait for the application to connect to the host, then tap [OK].
8. Transaction complete, the following receipt prompts will occur:
 - **[Paper]**, the merchant copy of the receipt is printed first, then followed by the customer receipt.
 - **[No Receipt]**, the merchant copy of the receipt is printed and no customer copy of receipt will be printed.

Phone Order

Phone Order is NOT enabled on your Global Payments Terminal by default. Please contact Global Payments' Customer Care at **1.888.682.3309** to enable this feature.

Use the optional **phone order** transaction to process card-not-present transactions, where the cardholder provides you with their order and payment details by regular mail, fax, or telephone.

NOTE:

To process credit surcharge for card-not-present transactions, please process it under the **Sale** function.

NOTE:

To process tips for card-not-present transactions, please process it under the **Sale** function.

1. Go to the Flex app. On the main menu, select **Retailer**.
 2. Tap **Phone Order**
 3. Enter the clerk or server ID (if enabled) and tap [→].
 4. Enter the invoice number and tap [→]
 5. Enter account number and tap [→].
 6. Enter expiration date and tap [→].
 7. Enter the cardholder's street address and tap [→].
 8. Enter the cardholder's postal Code and tap [→].
- NOTE:** No space when entering the postal code.
9. Enter the CVV and tap [→].

TIPS:

The CVV security code is on the back of the card, next to the signature panel.

10. Wait for the application to connect to the host, then tap [→].
11. Transaction complete, select one of the following options:

- **[Paper]**, the merchant copy of the receipt is printed first, then followed by the customer receipt.
- **[No Receipt]**, the merchant copy of the receipt is printed and no customer copy of receipt will be printed.

Synchronization

This feature is specific to Pay-At-The-Door mode integration. The "Synchronization" service is provided by the ECR/POS. When this service is triggered by the terminal, it notifies the POS that the terminal is ready to initiate synchronization of the transactions conducted while operating in PATD mode.

Synchronization is required when **closing a batch** and switching to a different operation mode.

NOTE:

- This feature is only supported in Pay at the Door (Nomad operation mode).
- When performing Synchronization, the terminal must be connected to the same Wi-Fi network as the POS.

1. On the Flex app main menu, tap **Synchronization**
2. Wait for the application to connect to the host and tap [OK]
3. Synchronization completed.

Performing an End Of Day (settlement)

You should perform a terminal settlement at least **once per day**. This ensures prompt payment and reduces the chance of chargebacks.

1. Go to the Flex app, on the main Menu select Close Batch.
2. Wait for the application to finish the process
3. Once the End of Day is complete, a **Close Batch Settlement** report is printed, giving the status of the closed batch operation. Confirm the report displays "**BATCH: # ##### ACCEPTED**" to verify that the settlement is complete.
4. A report will be printed and terminal displays "**BATCH # ##### ACCEPTED**"

These transactions will be processed and your account(s) will be credited. The funds will be available in your account(s) according to the arrangements you made with Global Payments.

Reprint

The Reprint Menu will present the Transaction List, which includes a comprehensive list of all processed transactions. Users will have the ability to reprint both the Merchant and Customer copies of any transaction listed.

The ECR/POS will not receive any response from the Flex when reprinting a receipt.

1. On the Flex app main menu, tap **Reprint**
2. Select a transaction from the list or use the **Search** field
 - a. The transaction list contains 2 tabs: Transactions and Offline
3. The selected transaction is displayed. Tap **Receipt**
4. Select a receipt type [Print Merchant Copy] or [Print Customer Copy], then tap **Continue**.
5. The selected copy will be printed.

Reports

To generate reports, follow the steps below:

1. Tap **Reports** on the Flex app home screen.
2. Terminal displays two batch types, select **[Current]** or **[Previous]**.

NOTE:

The Previous report will be dated back to the last 3 closed batches.

3. Terminal displays 3 reports for both Current and Previous batch types, select **[Summary]** or **[Detail]** or **[Both]**

NOTE:

The settlement report will print after a successful batch.

Remote update

Global Payments Terminal comes with auto remote update, so you can ensure that your terminal is always up-to-date with the latest **Global Payments Unified Payments Flex Application (Flex app)**.

Remote update is automatically fulfilled, **no action is required on your end.**

Replacing the paper roll

Change the paper roll when coloured stripes start to appear on the receipt.

CAUTION:

Only use paper approved by the manufacturer, the specifications to the terminal's paper are:

- **Roll Width:** 57 mm (2 ¼")
- **Roll Diameter:** 40 mm (1.57")
- **Roll Length:** 17 m (55')

Using unapproved paper can damage the terminal's printer.

To maximize the life of the thermal paper rolls, do not expose to fluorescent light, UV light, high humidity (above 65%), or temperature (above 4° C or 113° F) for a long period of time. Do not place them near vinyl, plastics, adhesives, shrink wraps, wet-toner copiers, or carbon paper for prolonged periods.

T650P

To change the paper roll, please follow the step-by-step instructions below:

1. Hold both sides of the paper door located on the upper corner of the device and gently pull it outward to open the paper door
2. Check the tray for any partial roll of paper and remove it if present

3. If the new paper roll has a glued leading edge or a protective strip, loosen the glue or remove the strip. Unwind the paper roll, making sure to go past any residue from the glue
4. Hold the paper roll in a way that allows the paper to feed from the top of the roll
5. Pull the paper past the printer door, ensuring it moves smoothly
6. Align the printer paper with the tabs or paper guides, and while holding the paper up, proceed to close the door
7. With the printer paper extending outside the device, close the printer door by swinging it upward until it clicks shut, while still allowing the paper to remain outside the printer door

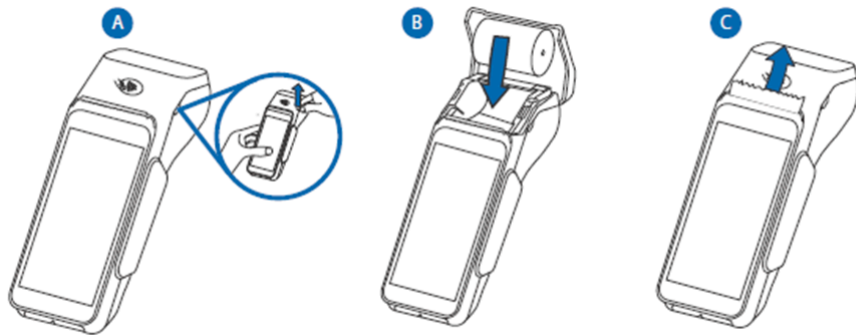

Troubleshooting

Card reader does not work properly ("Cards are Not Read")

To troubleshoot issues with card reading, please follow the steps below:

1. Ensure that when sliding the card through the reader, the magnetic stripe on the card faces the side of the terminal display screen. This ensures proper alignment for reading.
2. Adjust the speed of swiping the card. Try swiping it faster or slower at a steady pace to find the optimal speed that allows for successful card reading.
3. If swiping the card in one direction doesn't work, try swiping it in the opposite direction. This can sometimes resolve reading errors caused by misalignment.
4. Perform a test transaction using one or more different magnetic stripe cards. This helps determine if the problem lies with the card being used. If the issue persists with multiple cards, it indicates a potential problem with the terminal or reader.
5. Inspect the magnetic stripe on the card for any signs of damage, such as scratches or excessive wear. A damaged stripe can hinder proper card reading. To verify if the card is the cause of the problem, request another card from the customer or try swiping the card on a different terminal.

Terminal does not work properly

1. Make sure the power cable connector is fully inserted into the terminal or the base
2. Reboot the terminal:
 - a) Press and hold the **power button** [⏻] to wake the device up.
 - b) Press and hold the **power button** [⏻] until the user menu is displayed, then press **[Reboot]**.
3. Plug the terminal into another electrical outlet to see if it is an outlet problem.
4. If you have another working terminal, swap the terminals to determine if the problem is with the terminal, cable, or power outlet.

Receipt paper is jammed

- To avoid paper jams, tear the receipt by pulling the paper forward
- To clear a paper jam, remove the paper roll and reinsert it

Receipt is blank

If the receipt is blank, confirm that the roll of paper has been properly inserted into the terminal and the correct paper type is being used.

POS Comm error

This might be caused by a download that was performed and the IP address has returned to the default value or the ECR/POS IP address has been changed. To check if the IP address on the T650P matches with the ECR/POS IP address:

1. Obtain IP address from ECR/POS
2. Tap IP

Cleaning

CAUTION:

Before cleaning the terminal, ensure it is powered off.

To clean the terminal safely and effectively, please follow these instructions:

1. Unplug the power supply to prevent damage and electric shock.

2. Wipe the terminal with a damp cloth to remove dust.
3. Avoid excessive moisture and abrasive materials.
4. Pay attention to frequently touched areas.
5. Allow the terminal to air dry completely before powering it back on.

Service and support

For Global Payments Terminal service and repair information, contact Global Payments' Customer Care at **1.888.682.3309**.

Returning a terminal for service

When you receive a replacement terminal, it is important to promptly return the defective devices. Failure to do so may result in additional charges being applied to your account. If you have any questions regarding terminal returns, the Global Payments' Customer Care Centre is available to assist you.

NOTE:

Under no circumstances should you attempt to service, adjust, or repair the product yourself. Unauthorized service conducted by parties other than authorized Global Payments representatives is strictly prohibited. To ensure proper service, please contact Global Payments' Customer Care at **1.888.682.3309** for assistance.