

# User Manual **NIRS31-UMB**

**N**on  
**I**nvasive  
**R**oad  
**S**ensor

n for precision · passion pour la précision · pasión por la precisión · passione per la precisione · passion for precision ·

Please read the complete user manual before installation



 **Lufft**

— an OTT HydroMet brand —

[www.otthydromet.com](http://www.otthydromet.com) [www.lufft.com](http://www.lufft.com)

Address

OTT HydroMet Fellbach GmbH  
Gutenbergstrasse 20  
70736 Fellbach  
Deutschland  
Tel.: +49 (0)711 51822-0  
[www.lufft.com](http://www.lufft.com)  
[met-info@otthydromet.com](mailto:met-info@otthydromet.com)



48.7230-NIRS31  
Document version V8.5 (2023-Feb-10)

## Contents

<b>1</b>	<b>Please Read Before Use</b> .....	<b>5</b>
1.1	Symbols Used .....	5
1.2	Safety Instructions .....	5
1.3	Designated Use .....	5
1.4	Incorrect Use .....	5
1.5	Guarantee .....	5
1.6	Brand Names .....	5
1.7	Primary / Secondary (Client / Server) Terminology .....	5
<b>2</b>	<b>Scope of Delivery</b> .....	<b>6</b>
<b>3</b>	<b>Order Numbers</b> .....	<b>7</b>
3.1	Accessories .....	7
3.2	Spare Parts .....	7
3.3	Additional Documents and Software .....	7
<b>4</b>	<b>Equipment Description</b> .....	<b>8</b>
4.1	Road Surface Temperature .....	8
4.2	Water Film Height .....	8
4.3	Ice Layer Thickness .....	8
4.4	Road Condition .....	8
4.5	Ice Percentage .....	8
4.6	Freezing Temperature .....	8
4.7	Saline Concentration .....	9
4.8	Snow Height .....	9
4.9	Friction .....	9
4.10	Sensor Technology NIRS31-UMB .....	10
<b>5</b>	<b>Generation of Measurements</b> .....	<b>11</b>
5.1	Current Measurement (act) .....	11
<b>6</b>	<b>Operation Modes</b> .....	<b>11</b>
6.1	Normal Operation .....	11
6.2	Energy Saving Mode .....	11
<b>7</b>	<b>Measurement Output</b> .....	<b>12</b>
7.1	Measurements .....	12
7.2	Additional Sensor Information .....	15
<b>8</b>	<b>Installation</b> .....	<b>17</b>
8.1	Fastening .....	17
8.2	Aligning the Sensor .....	18
8.3	Selecting the Installation Location .....	19
<b>9</b>	<b>Connections</b> .....	<b>22</b>
9.1	Equipment Connector .....	22
9.2	Pin Assignment .....	22
9.3	Supply Voltage .....	22
9.4	RS485 Interface .....	23
9.5	Connection to ISOCON-UMB (8160.UISO) .....	23
9.6	Use of Surge Protection (8379.USP) .....	23
9.7	SDI-12 Interface .....	24
<b>10</b>	<b>Commissioning</b> .....	<b>25</b>
10.1	Conditions for the Initial Commissioning .....	25
10.2	Important Instructions for Commissioning .....	25
<b>11</b>	<b>Sensor Adjustment</b> .....	<b>26</b>
11.1	Readjustment using the UMB Config Tool .....	26
11.2	Adjustment during Operation .....	26
<b>12</b>	<b>Configuration and Testing</b> .....	<b>27</b>
12.1	Factory Settings .....	27

12.2	Configuration with the UMB Config Tool .....	27
12.3	Function Test with the UMB Config Tool .....	29
<b>13</b>	<b>Firmware Update .....</b>	<b>30</b>
<b>14</b>	<b>Maintenance.....</b>	<b>31</b>
14.1	Replacing the Reflector Unit .....	31
14.2	Cleaning the Transmitter and Receiver Plates .....	32
14.3	Resetting the Service Level .....	32
14.4	Function Test .....	33
14.5	Checking the Sensor Adjustment.....	33
14.6	Generate Status File .....	33
<b>15</b>	<b>Technical Data .....</b>	<b>34</b>
15.1	Measurement Range / Accuracy .....	35
15.2	Drawings.....	36
<b>16</b>	<b>Fault Description .....</b>	<b>37</b>
<b>17</b>	<b>Disposal .....</b>	<b>38</b>
17.1	Within the EC .....	38
17.2	Outside the EC .....	38
<b>18</b>	<b>Repair / Corrective Maintenance.....</b>	<b>38</b>
18.1	Technical Support.....	38
<b>19</b>	<b>Appendix .....</b>	<b>39</b>
19.1	Channel List Summary.....	39
19.2	Channel List Summary per TLS2002 FG3 .....	40
19.3	Communication in Binary Protocol .....	41
19.4	Communication in ASCII Protocol.....	44
19.5	Communication in SDI-12 Mode .....	46

## 1 Please Read Before Use

Please read this Operating Manual carefully and keep it handy for future reference. Please note that various components of the sensor and the described software may look somewhat different from those shown in the illustrations in this operating manual.

**This manual is valid for devices of the Lufft NIRS31-UMB with device version 33 or higher (11/2022). Some functions or features specified in this manual may not be available or may not be valid with older device versions.** The device version is indicated as the last number of the serial number printed on the type plate, e.g.: the device with SN: 063.1010.0707.**014** has the device version 14.

### 1.1 Symbols Used



Important information concerning potential hazards to the user



Important information concerning the correct operation of the equipment

### 1.2 Safety Instructions



- Installation and commissioning must only be carried out by suitably qualified specialist personnel.
- Never take measurements on or touch live electrical parts.
- Pay attention to the technical data and storage and operating conditions.

### 1.3 Designated Use



- The equipment must only be operated within the range of the specified technical data.
- The equipment must only be used under the conditions and for the purposes for which it was designed.
- The safety and operation of the equipment can no longer be guaranteed if it is modified or adapted.

### 1.4 Incorrect Use

If the equipment is not correctly installed:



- It may not function or its operation may be limited.
- It may be permanently damaged.
- Danger of injury may exist if the equipment is allowed to fall.

If the equipment is not correctly connected:



- It may not function.
- It may be permanently damaged.
- The possibility of an electrical shock may exist under certain circumstances.

### 1.5 Guarantee

The guarantee period is 24 months from the date of delivery. The guarantee is forfeited if the designated use is violated.

### 1.6 Brand Names

All brand names referred to are subject without limitation to the valid trademark and ownership rights of the respective owner.

### 1.7 Primary / Secondary (Client / Server) Terminology

In this documentation, the terminology primary / secondary ([ISC](#)) is used to describe communication processes.

## 2 Scope of Delivery

The content of the delivery consists of the following components:

- Sensor NIRS31-UMB

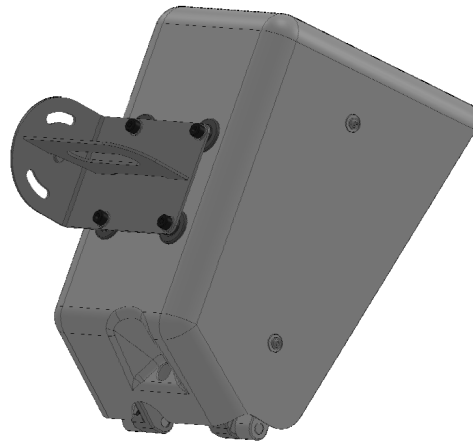

- Mast clamp

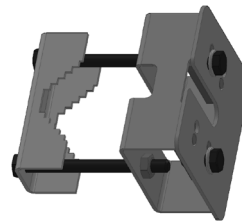

- Sounding pipe

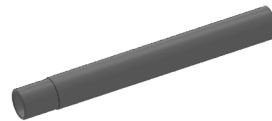

- Operating manual



- Transport packaging



**Note:** The delivery **does not include a connection cable**; this must be ordered separately (see Accessories page 7).



**Note:** The sensor must always be transported in the original packaging, as otherwise it will be damaged.

### 3 Order Numbers

#### NIRS31-UMB 8710.UT01

- Non-invasive road sensor including integrated road surface temperature sensor

#### 3.1 Accessories

- 15m connection cable with connector 8371.UK015
- 30m connection cable with connector 8371.UK030
- Power supply unit 24V/100VA 8366.USV1
- ISOCON-UMB 8160.UIISO
- Surge protection 8379.USP

#### 3.2 Spare Parts

- Reflector unit 8710.ULAMP

#### 3.3 Additional Documents and Software

You can download the following documents and software via the Internet at [www.lufft.com](http://www.lufft.com) or [www.otthydromet.com](http://www.otthydromet.com).

- Operating Manual This document
- UMB Config Tool Windows® software for testing, firmware updates and configuration of UMB devices
- UMB Protocol Communication protocol for UMB devices
- Firmware The current equipment firmware
- Additional Accessories and software Please check our webpages or contact your sales representative for further accessories, spare parts or related software.

## 4 Equipment Description

Depending on the requirements of the road traffic meteorological monitoring network, sensors are installed in the roadways and / or "overhead". The Lufft NIRS31-UMB completes the product range to include a non-invasive, intelligent sensor. The NIRS31-UMB provides an alternative to the Lufft IRS31-UMB, especially for measuring points such as bridges, which do not always allow direct installation of sensors in the roadway. In addition, at points where asphalt repairs often take place, it is no longer necessary to remove the sensor technology during repair works. The optical measuring device NIRS31-UMB for the detection of water, ice and snow can be mounted on a bridge or mast. The measurement distance between the measuring device and the road surface can be from 6 to 15 meters.

The sensor delivers established and commonly used decision-making data to winter maintenance services, including water film height, road condition, road surface temperature and freezing temperature. In addition, the sensor provides ice percentage and snow depth readings. As the ice percentage on the road surface increases, the friction coefficient falls off and this can be used as a guide in preventive road gritting decision-making.

In contrast to built-in road sensors, non-invasive sensors are not able to measure underground soil temperature.

The equipment is connected by way of an 8 pole plug-in terminal and associated connection cable (available in lengths of 15m and 50m).

The measured values can be requested over the RS485 interface in accordance with the UMB protocol.

During commissioning, configuration and measurement polling takes place using the UMB Config Tool (Windows®PC software).

### 4.1 Road Surface Temperature

Road surface temperature is measured by means of a non-invasive pyrometer, which is fully integrated into the sensor.

### 4.2 Water Film Height

Measurement of the water film height on the road surface takes place by means of non-invasive optical spectroscopy. The water film height is the proportion of liquid water.

### 4.3 Ice Layer Thickness

Measurement of the ice layer thickness on the road surface takes place by means of non-invasive optical spectroscopy.

**The ice layer thickness indicates the proportion of the frozen water as water equivalent. The sum of water film height and ice layer thickness results the total water equivalent.**

### 4.4 Road Condition

The current road condition is determined from the measurement of water film height and road surface temperature. The sensor calculates the following conditions: dry, damp, wet, snow / ice and critical wetness.

### 4.5 Ice Percentage

The proportions of frozen solution are determined from the measurement data provided by optical spectroscopy and transmitted as the ice percentage.

### 4.6 Freezing Temperature

The freezing temperature is determined on the basis of the current road surface temperature and the measured ice percentages.

**Note:** The freezing temperature can only be determined if ice percentages have already formed. Determination of freezing temperature is currently limited to the de-icing agent sodium chloride (NaCl).





#### 4.7 Saline Concentration

The saline concentration is calculated from the current freezing temperature.



**Note:** The saline concentration can only be determined if ice percentages have already formed. Determination of saline concentration is currently limited to the de-icing agent sodium chloride (NaCl).

#### 4.8 Snow Height

The sensor detects the snow height in the field of measurement.



**Note:** the snow height is an additional information and it is not part of the water equivalent.

#### 4.9 Friction

Friction describes the grip of tires on the road surface. This can be reduced as a result of environmental influences such as rain or snow. The value of the friction is scaled between 0.1 and 1.0. High values indicate a good grip, and low values indicate a bad grip. The highest value is reached in dry road conditions. If there is water on ice the lowest value is the result.

#### 4.10 Sensor Technology NIRS31-UMB

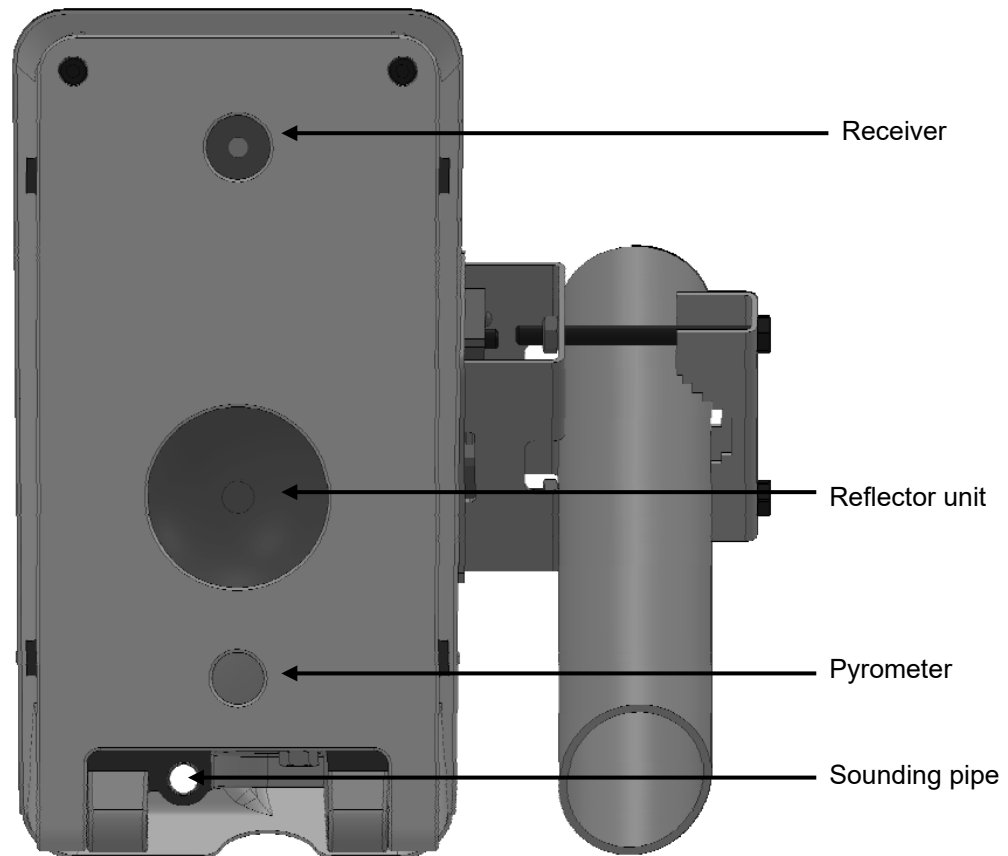

Fig. 1: Sensor Technology

## 5 Generation of Measurements

### 5.1 Current Measurement (act)

The value of the last measurement is transmitted when the current measurement value is requested.

## 6 Operation Modes

The sensor can be operated in two different modes.

### 6.1 Normal Operation

Provided that the power supply is not limited, this mode is recommended because it is not restricted.

In normal operation, the sensor continually measures and provides continuously updated measurement values.

### 6.2 Energy Saving Mode

If the power supply is limited, it is possible to operate the sensor in energy saving mode. In this mode the sensor samples only one time per minute. Between the measurements, the sensor is switched to a standby mode. Thereby the power consumption is reduced on average to lower than 35%.

#### 6.2.1 Restrictions in Energy Saving Mode

**Note:** Setting the sensor to energy saving mode has the following restrictions:

- The sampling and data update rate is fixed at 1 minute.
- The first 3 minutes after starting the device and during the measurement, the NIRS31-UMB is running at full capacity, therefore, the supply has to be designed for full power.
- The response time may be delayed.
- In case of rapid changes of the road conditions (e.g. onset of rainfall) it is used to measured more often to reduce the response time; thereby, the power consumption may increase slightly.
- In case of heavy traffic load, it is used to measured more often for a proper function of the noise suppression; this maybe increase the power consumption
- Very high traffic load can cause interference of the measurement.
- Due to the low power, the sensor can freeze rather

## 7 Measurement Output

The factory default setting for the transmission of measurements is UMB binary protocol.

You can find an example of a measurement request for the various protocols and a complete summary of the list of channels in the Appendix.

### 7.1 Measurements

#### 7.1.1 Road Surface Temperature

Sampling rate 1 minute

Units °C; °F

Request channels:

UMB Channel				Measurement Variable (float32)	Measuring Range		
act	min	max	avg		min	max	unit
100				Road surface temperature	-40.0	70.0	°C
101				Road surface temperature	-40.0	158.0	°F

#### 7.1.2 Freezing Temperature

Sampling rate <1 minute

Units °C; °F

Request channels:

UMB Channel				Measurement Variable (float32)	Measuring Range		
act	min	max	avg		min	max	unit
110				Freezing temperature NaCl	-40.0	0.0	°C
111				Freezing temperature NaCl	-40.0	32.0	°F

#### 7.1.3 Water Film Height

Sampling rate <1 minute

Units µm; mil

Request channels:

UMB Channel				Measurement Variable (float32)	Measuring Range		
act	min	max	avg		min	max	unit
600				Water film height	0.0	2000.0	µm
605				Water film height	0.0	78.7	mil

#### 7.1.4 Ice Layer Thickness

Sampling rate <1 minute

Units µm; mil

Request channels:

UMB Channel				Measurement Variable (float32)	Measuring Range		
act	min	max	avg		min	max	unit
601				Ice layer thickness	0.0	2000.0	µm
606				Ice layer thickness	0.0	78.7	mil

The indication of ice layer thickness corresponds to the water equivalent.

**7.1.5 Road Condition**

Sampling rate <1 minute  
 Units logic coding  
 Request channels:

UMB Channel				Measurement Variable (uint8)	Coding	
act						
900				Road condition	0	Dry
					1	Damp
					2	Wet
					3	Ice
					4	Snow / ice
					5	Chemically wet
					6	Critically wet
					8	Snow
					99	Undefined

- dry: on the road there is no liquid water, the water film height is less than the damp threshold
- damp: on the road there is liquid water; the water film height is less than the wet threshold
- wet: on the road there is liquid water; water film height is equal or greater than the wet threshold
- snow / ice: frozen water is on the road; it's in the form of snow or ice; a differentiation is not possible.
- snow: frozen water is on the road; it's mostly in the form of snow
- ice: frozen water is on the road; it's mostly in the form of ice
- chemically wet: water film height is equal to or greater than the damp threshold and the road temperature is below 1.5 °C, the formation of ice is prevented by using de-icing chemicals.
- critically wet: water film height is equal to or greater than the damp threshold and the road temperature is below 1.5 °C, the formation of ice particles has already begun.

The thresholds for damp and wet in the factory settings are 30 and 100µm, they can be adjusted in the sensor configuration.

**7.1.6 Ice Percentage**

Sampling rate &lt;1 minute

Units %

Request channels:

UMB Channel				Measurement Variable (float32)	Measuring Range		
act	min	max	avg		min	max	unit
800				Ice percentage	0.0	100.0	%

**7.1.7 Saline Concentration**

Sampling rate &lt;1 minute

Units %

Request channels:

UMB Channel				Measurement Variable (float32)	Measuring Range		
act	min	max	avg		min	max	unit
810				Saline concentration NaCl	0.0	100.0	%

**7.1.8 Snow Height**

Sampling rate &lt;1 minute

Units mm

Request channels:

UMB Channel				Measurement Variable (float32)	Measuring Range		
act	min	max	avg		min	max	unit
610				Snow height	0.0	10.0	mm

**7.1.9 Friction**

Sampling rate &lt;1 minute

Units none

Request channels:

UMB Channel				Measurement Variable (float32)	Measuring Range		
act	min	max	avg		min	max	unit
820				Friction	0.0	1.0	none

## 7.2 Additional Sensor Information

The sensor delivers further information about the condition and operation of the sensor.

### 7.2.1 Service Level

UMB Channel				Measurement Variable (sint16)	Measuring Range		
act					min	max	unit
4000				Service level		100	%

100% Equipment recently serviced

< 12% Service due in less than 90 days

< 4% Service due in less than 30 days

A negative value indicates that the due service period has been exceeded.

### 7.2.2 Remaining Time to Next Service

UMB Channel				Measurement Variable (sint16)	Measuring Range		
act					min	max	unit
4001				Remaining time to next service		17520	h

Indicates the number of hours to the next service.

A negative value indicates that the due service period has been exceeded.

### 7.2.3 Lamp Status

UMB Channel				Measurement Variable (uint8)	
act					
4002				Lamp status	0 Lamp OK 1 Lamp faulty



**Note:** In the event of a faulty lamp it is necessary to change the reflector unit to restore correct operation.

### 7.2.1 Measure Status

UMB Channel				Measurement Variable (uint8)	
act					
4003				Measure Status	

Bit 0	Status Transmitter	0 transmitter is working properly 1 transmitter is not working properly; in case of permanent state, please contact hotline
Bit 1	Status Receiver	0 receiver is working properly 1 receiver is not working properly; in case of permanent state, please contact hotline
Bit 2	Status Temperature	0 measurement is working properly 1 interference suppression of implausible temperature values is active; for example, it can be caused by a stationary vehicle under the sensor; after this failure the sensor is working properly again
Bit 3	Status Pyrometer	0 measurement is working properly 1 interference suppression of implausible pyrometer values is active; for example, it can be caused by a stationary vehicle under the sensor; after this failure the sensor is working properly again
Bit 4	Status Signal	0 measurement is working properly 1 interference suppression of implausible signals is active; for example, it can be caused by a stationary vehicle under the sensor; after this failure the sensor is working properly again

### 7.2.2 Energy consumption ratio

UMB Channel				Measuring Range			
act				Measurement Variable (float32)	min	max	unit
4004				energy consumption ratio	0.0	100.0	%

In normal operation mode, the energy consumption ratio and thus the energy consumption is always 100%, because the sensor is in continuous operation. In energy save mode, the value is the energy consumption ratio of the last hour.



## 8 Installation

The sensor bracket is designed for installation on a mast with a diameter of 60 – 76mm.

The following tools are required for the installation:

- 2 open-end or box wrenches, SW17

### 8.1 Fastening

Attach the bracket to the mast at the prescribed height using the bolts, nuts and washers provided. Hold the nut firmly with one wrench and tighten the bolts evenly and securely with the second wrench.

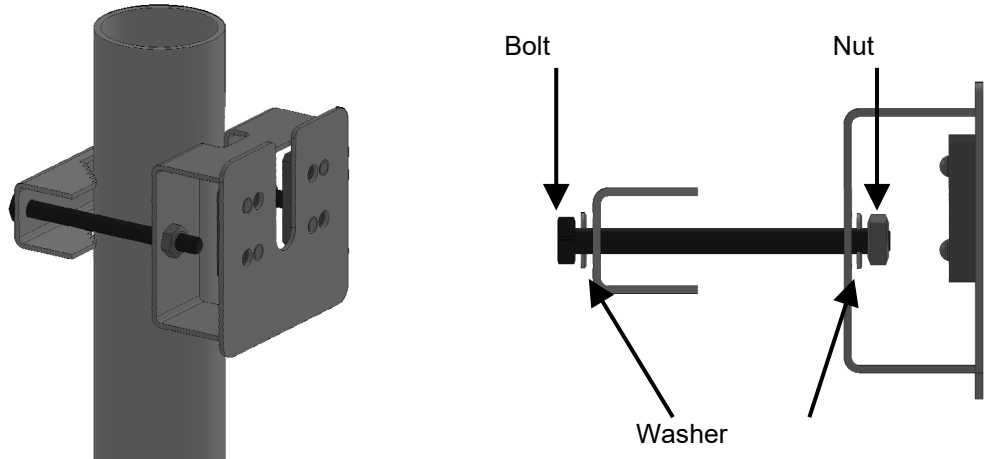

Fig. 2: Mast Bracket



**Note:** Select the correct bolts in accordance with the diameter of the mast:

60 – 69 mm mast diameter: 100 mm long bolts

70 – 76 mm mast diameter: 120 mm long bolts

Attach the sensor to the bracket from above and fasten using the bolts and washers provided. Tighten the bolts but make sure that the sensor can still be moved.

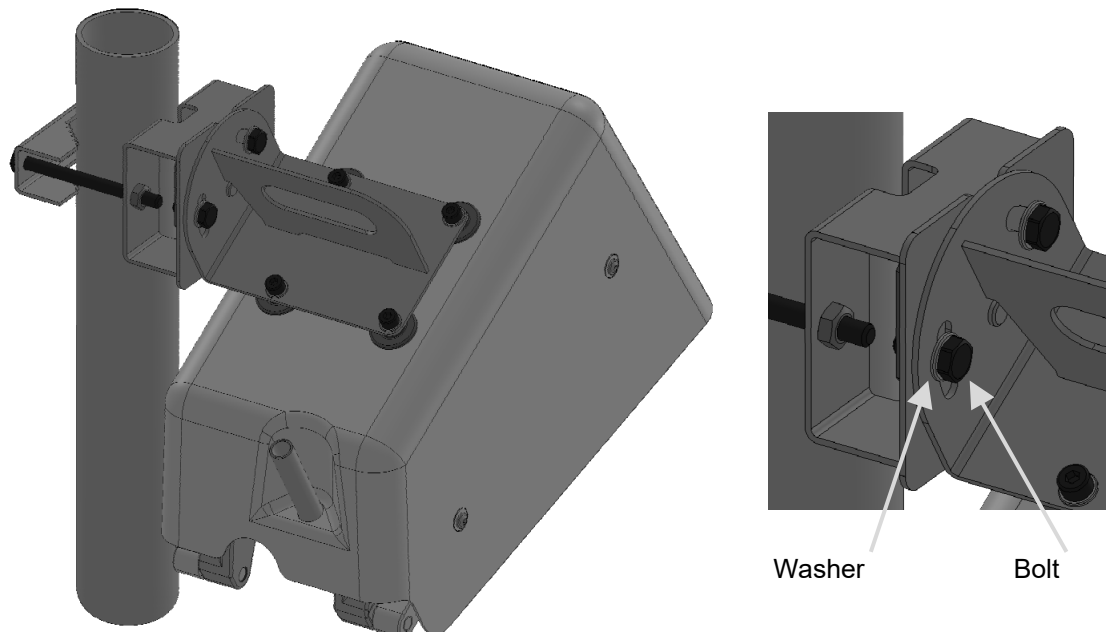

Fig. 3: Sensor Attachment

## 8.2 Aligning the Sensor

A look through the small tube (sounding pipe) on the bottom of the sensor indicates the center of the measurement field on the road surface. Align the sensor with the center of the roadway while retaining the angle of measurement (between 45 and 85°) and firmly tighten the bolts.

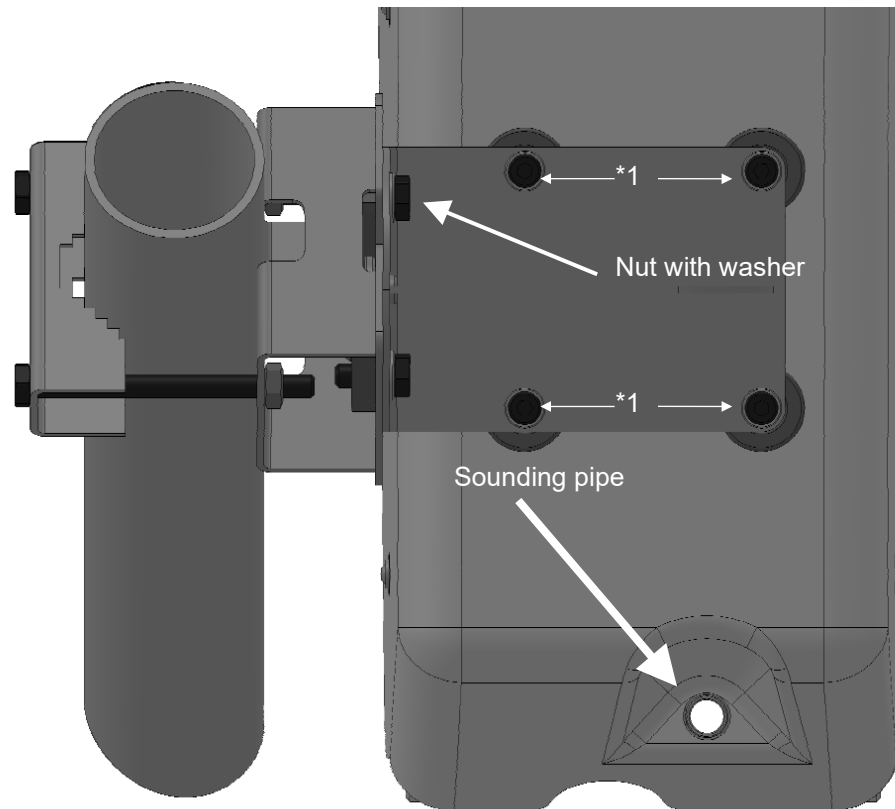

Fig. 4: Aligning the Sensor



**Note:** If you wish to attach the sensor to the opposite side of the mast, you can adjust the bracket on the sensor **prior to installation**. To do this, remove the 4 bolts marked \*1, rotate the bracket by 180° and reattach with the 4 bolts.

### 8.3 Selecting the Installation Location

In order to guarantee long service life and correct equipment operation, please pay attention to the following points when selecting the installation location.

#### 8.3.1 General Instructions

- Stable subsurface for installing the mast
- Free access to the equipment for maintenance works
- Reliable power supply for permanent operation
- Good network coverage when transmitting over a mobile communications network



**Note:** The computed measurements specifically apply to the equipment location only. No conclusions can be drawn with regard to the wider environment or a complete road section.

#### ATTENTION:



- Only approved and tested appliances (conductors, risers etc.) should be used to install the device on the mast.
- All relevant regulations for working at this height must be observed.
- The mast must be sized and anchored appropriately.
- The mast must be grounded in accordance with regulations.
- The corresponding safety regulations for working at road side and in the vicinity of the roadway must be observed.
- Special safety precautions are required when working on roadways in use.



If the equipment is not correctly installed:

- It may not function.
- It may be permanently damaged.
- Danger of injury may exist if the equipment is allowed to fall.

#### 8.3.2 Roadway Condition

The measurement surface of the roadway should be as even, flat and level as possible.



**Important note:** The measurement surface of the roadway must be free of disturbances and flaws, e.g. road markings, manhole covers, potholes or cracks.

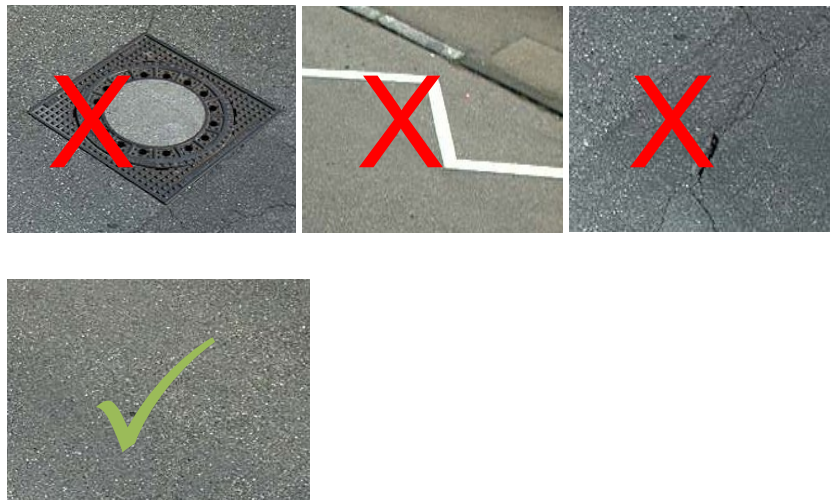

Fig. 5: Roadway Condition

### 8.3.3 Installation Sketch Mast

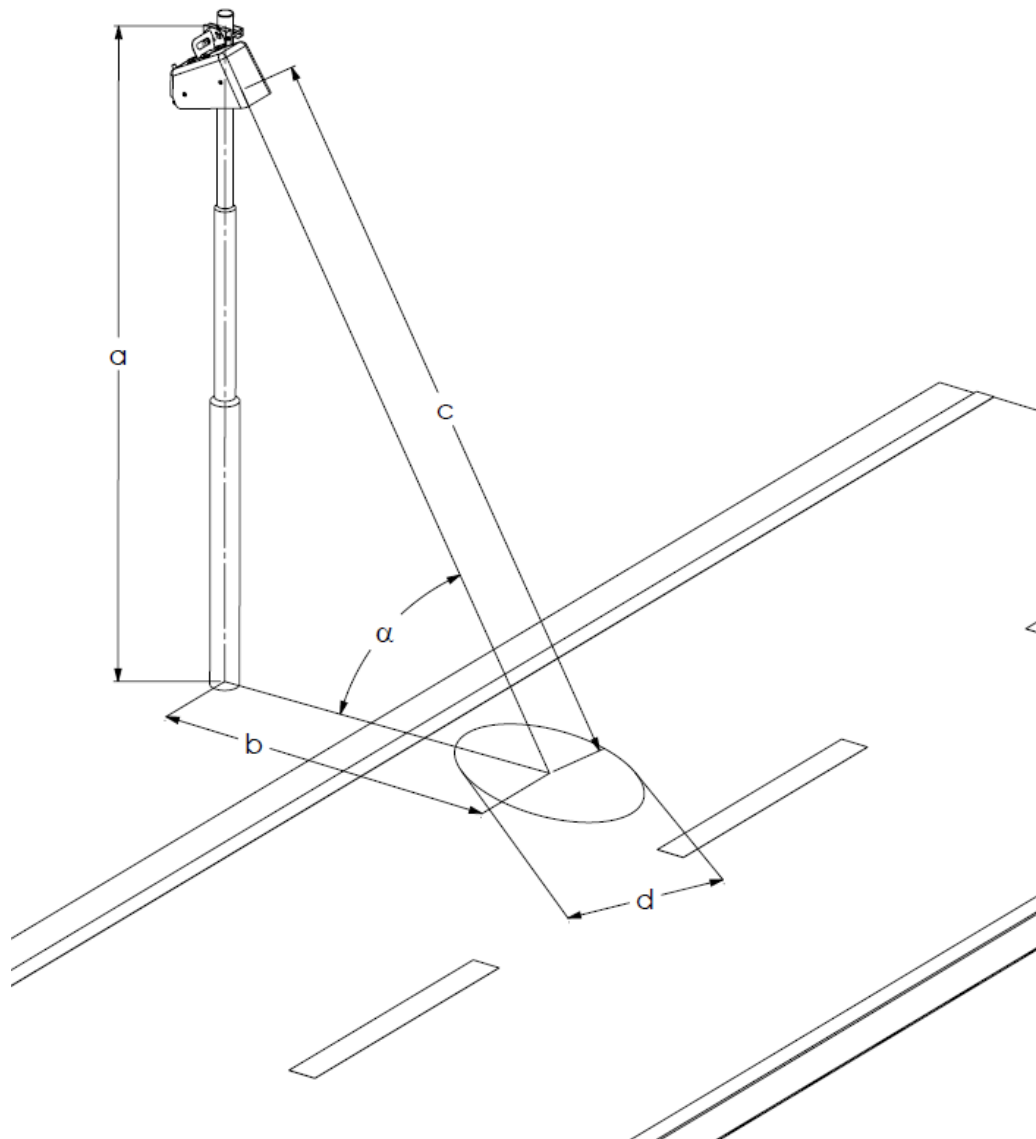

Fig. 6: Installation Sketch Mast

Measurement distance c:      6 to 15m  
Measurement angle  $\alpha$ :      between 45 and 85°  
Measurement surface diameter  $d = \text{measurement distance } c / 10$

### 8.3.4 Installation Sketch Gantry

Lateral view from the side of the road.

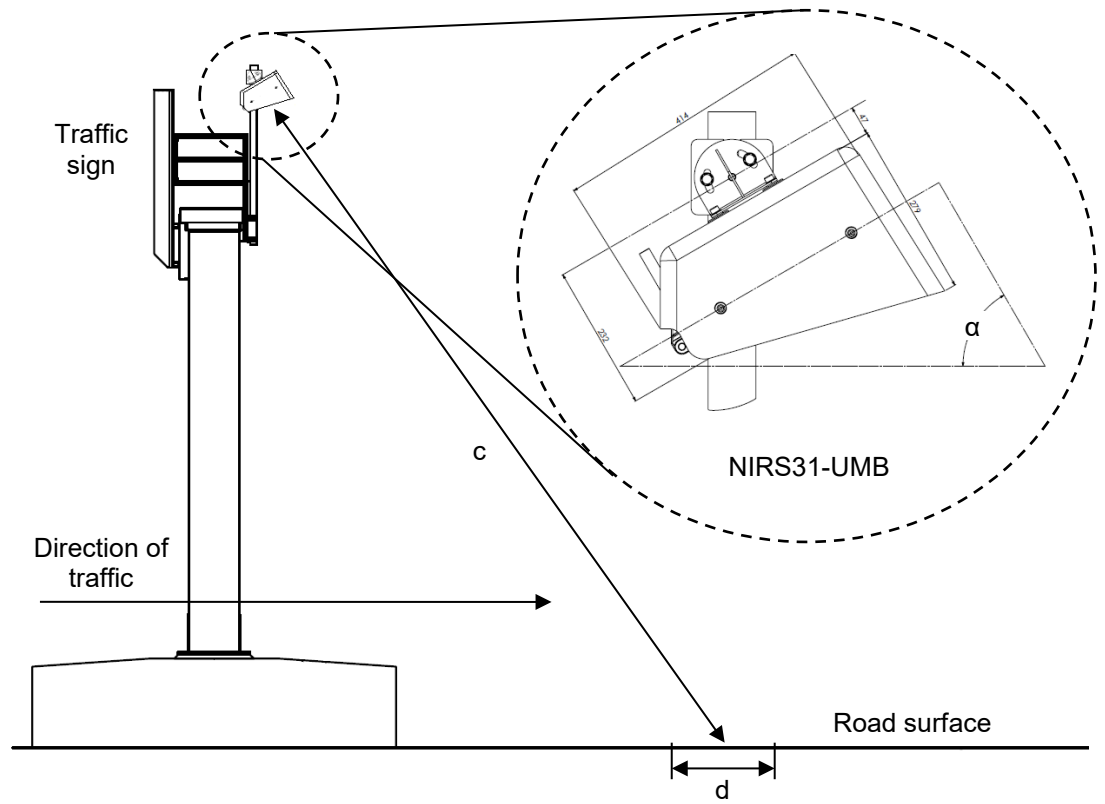

Fig. 7: Installation Sketch Gantry

- Measurement distance  $c$ : 6 to 15m
- Measurement angle  $\alpha$ : between 45 and 85°
- Measurement surface diameter  $d = \text{measurement distance } c / 10$

## 9 Connections

There is an 8 pole plug-in terminal on the bottom of the equipment. This serves to connect the supply voltage and interface. The connection cable must be ordered separately in the desired length (15 or 50 meters) (see page7).

### 9.1 Equipment Connector

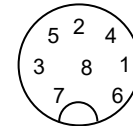
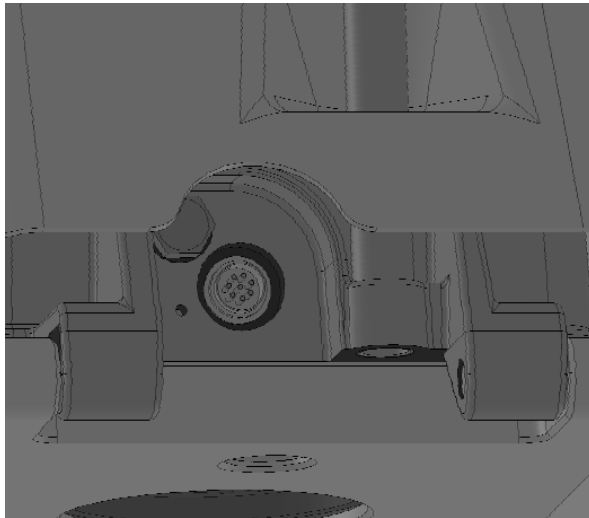

View on cable socket solder connection

Fig. 8: Connector

### 9.2 Pin Assignment

White	Ground $V_{GND}$ / SDI-12 GND	(7)
Brown	Supply voltage +24 $V_{DC}$	(8)
Green	RS485_A	(5)
Yellow	RS485_B / SDI-12 Data Line	(2)
Grey	Not used	(4)
Pink	Not used	(1)
Blue	Not used	(6)
Red	Not used	(3)

Cable markings are in accordance with DIN 47100.



**Note: the connection cable screen must NOT be laid to ground in the control panel.**



If the equipment is not connected correctly:

- It may not function.
- It may be permanently damaged
- The possibility of an electrical shock may exist under certain circumstances

### 9.3 Supply Voltage

The nominal supply voltage for the sensor is 24VDC. The power supply unit must be approved for operation with equipment of protection class III (SELV).



**Note: the supply voltage must be available at the sensor! Make sure that the voltage drop of the supply line is considered!**

The voltage drop when using the 15m standard cable 8371.UK015 is approx. 1.2 V. The bias voltage at the power supply unit should ideally be higher by this amount. Since the sensor consumes less power in energy saving mode, the voltage drop is lower in this case, which should be taken into account when selecting the maximum voltage at the power supply unit. The maximum voltage applied to the sensor must not exceed 28 VDC. If longer cable lengths than 30m are required, the original cable should be run as short as possible to a terminal box. The further connection to the control cabinet must be provided with a larger conductor cross-section.

**9.4 RS485 Interface**

The equipment has an electrically isolated, half-duplex, 2 wire RS485 interface for configuration, measurement polling and the firmware update. See page 34 for technical details.

**9.5 Connection to ISOCON-UMB (8160.UISO)**

The specified max. current of the ISOCONs 24V output is sufficient for the operation of the NIRS-UMB. However it may happen, that the current increases due to voltage drops between power supply unit and sensor and rises beyond the current limit of the ISOCON-UMB.



Therefore the power supply lines of NIRS31-UMB are not connected to the ISOCON but directly to the power supply unit, as shown by the following wiring diagram.

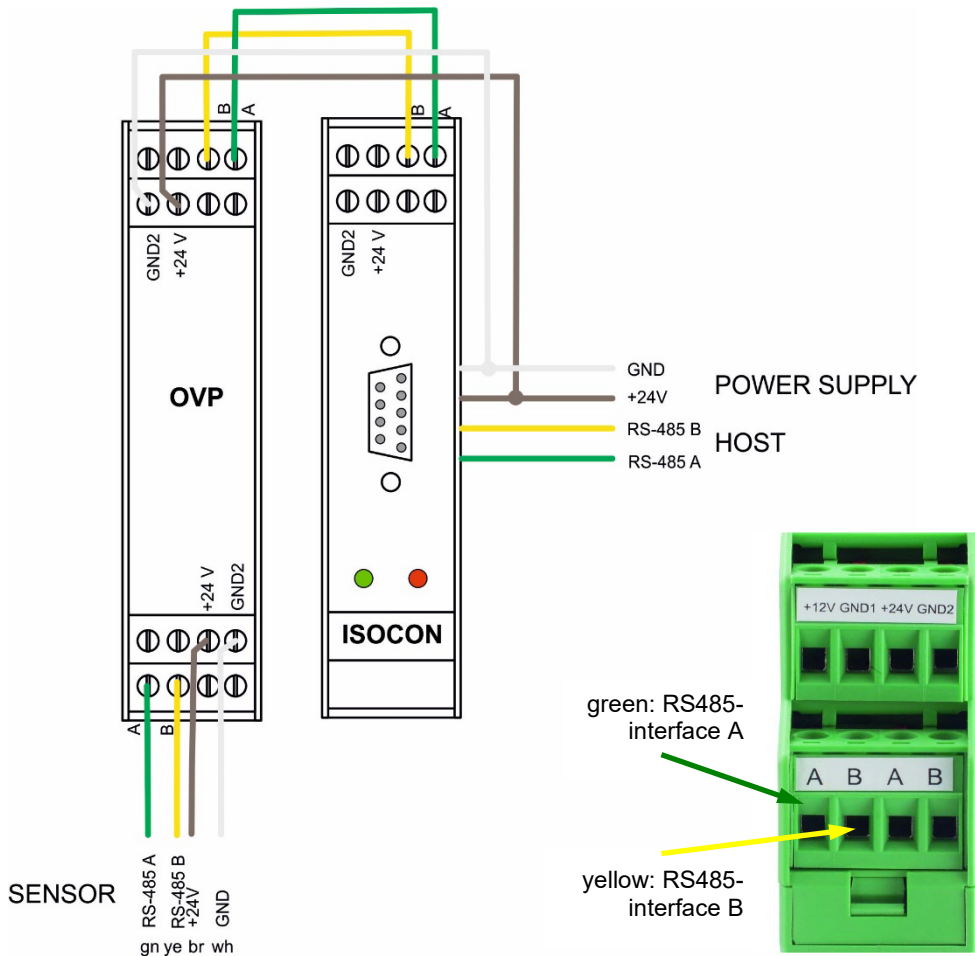

Fig. 9: RS485 and power supply connection at ISOCON and USP

If the sensors are connected to a Lufft LCOM-UMB the NIRS31-UMB should not use the UMB voltage output of the LCOM (GUB1/GMS) but connect directly to the power supply unit. To keep the LCOM function of resetting sensors on the UMB bus by cycling the supply voltage the NIRS31-UMB supply can be switched by a relay driven by GUB1.



**Note:** Please refer to the ISOCON-UMB operating manual when assembling the system.

**9.6 Use of Surge Protection (8379.USP)**

The installation of surge protection (order no.: 8379.USP) is strongly recommended. Please refer to the connection example in the surge protection operating manual.

## 9.7 SDI-12 Interface

Figure 10 shows how to connect the SDI-12 communication lines SDI12 (signal data, yellow wire from the NIRS31) and SDI12 (GND, white, common ground wire).



**Note:** The SDI-12 connection type has been changed with device version 33 and with the manual V8.5 !

Fig. 10: SDI-12 connection

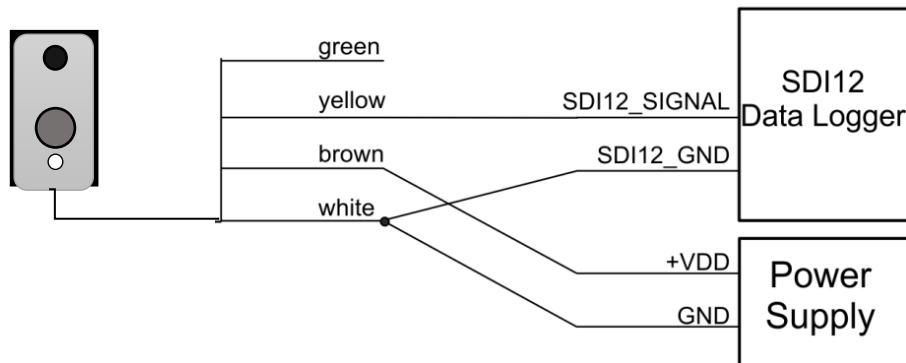



## 10 Commissioning

A Windows® PC with serial interface, UMB Config Tool software and interface cable (SUB-D 9 pole; jack - socket; 1:1) are required for configuration and test purposes.

### 10.1 Conditions for the Initial Commissioning

During the initial commissioning of the sensor and the associated adaptation, the following conditions must be met for the period of commissioning (10 minutes):

- Completion of installation / assembly / sensor alignment
- **Completely dry roadway**
- No traffic jam on the road
- No interruption to the power supply

### 10.2 Important Instructions for Commissioning



**Please pay attention to the following points:**

- Acquaint yourself with the functionality of the UMB Config Tool.
- Only switch on the power supply after the installation is complete.
- Readjustment is necessary in the event of any change to the position, alignment and measurement distance or installation location.
- **Commissioning / adjustment are not possible if the roadway is not dry; this must be performed manually at a later time at a dry roadway using the UMB Config Tool.**
- It may take longer to complete the adjustment if commissioning takes place during a period of heavy traffic.
- Readjustment is necessary if the power supply is interrupted during adjustment.
- Additional restarts after adjustment has been completed do not affect the measurements as the adjustment data are permanently stored.
- The equipment should be checked for correct operation on site by performing a measurement request with the aid of the UMB Config Tool (see page 29).
- If several NIRS31-UMB devices are operated on a UMB network, a unique device ID must be assigned to each device (see page 28).

## 11 Sensor Adjustment

An adjustment is required during commissioning in order to correctly adapt the sensor to the conditions at the installation location.

**Note: Please refer to the conditions and instructions on page 25.**



### 11.1 Readjustment using the UMB Config Tool

In sensor selection, select a NIRS31-UMB with associated ID (ID 1 in this example):

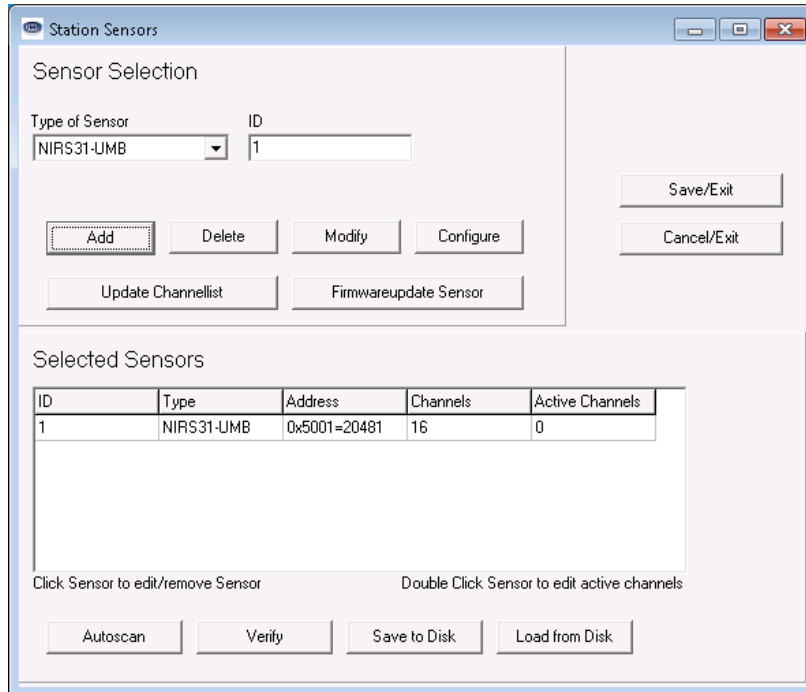

Check the sensor in the list with a mouse click and select the 'Configure' function.

In sensor configuration, now select the 'Load profile from sensor' function.

Select the 'NIRS-UMB' tab and in 'Device parameters' check 'renew Adaption':

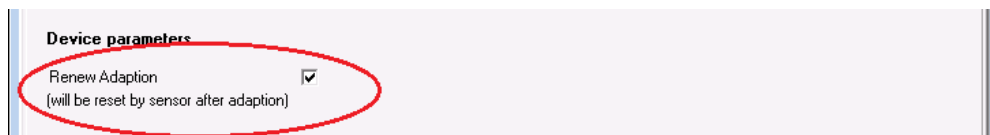

Fig. 11: New Adjustment

In the 'Main' tab, now select the 'store profile on sensor' function.

The sensor automatically commences the adjustment after a restart.

### 11.2 Adjustment during Operation

The adjustment is checked permanently during operation and adjusted automatically, where appropriate, for example to compensate for changes to the asphalt due to deterioration.

## 12 Configuration and Testing

Lufft provides Windows®PC software (UMB Config Tool) for configuration purposes. The sensor can also be tested and the firmware updated with the aid of this software.

### 12.1 Factory Settings

The sensor is delivered with the following settings:

Class ID: 5 (cannot be modified)  
 Device ID: 1 (gives address 5001h = 20481d)  
 Baud rate: 19200  
 RS485 protocol: UMB binary  
 Calculation interval: 10 measurements  
 Pyrometer offset: 0°C  
 Pyrometer emissivity: 0.95  
 Water film moisture threshold: 30 µm  
 Water film wetness threshold: 100 µm



**Note:** The device ID must be changed if several non-invasive road sensors are operated on a UMB network, as each device requires a unique ID. It makes sense to start from ID 1 and continue in ascending order.

### 12.2 Configuration with the UMB Config Tool

The operation of the UMB Config Tool is described in detail in the operating instructions for the Windows® PC software. For this reason only the menus and functions specific to this sensor are described here.

#### 12.2.1 Sensor Selection

In 'Sensor Selection', the road sensor is displayed as NIRS31-UMB (Class ID 5).

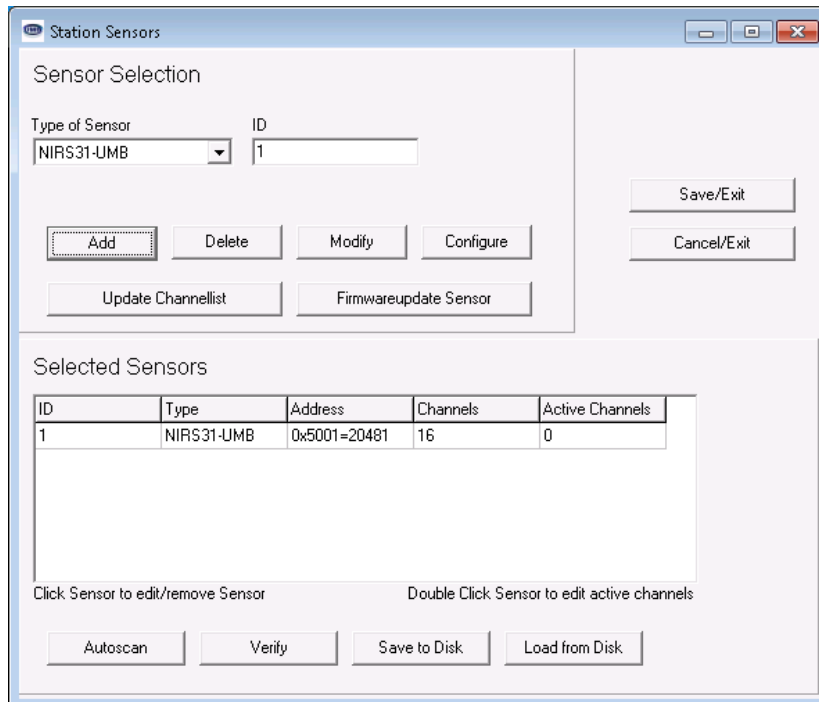

Fig. 12: Sensor Selection



**Note:** All other devices which are used in the polling process, e.g. modems, LCOM etc., must be disconnected from the UMB network during configuration.

### 12.2.2 Configuration

After a configuration has been loaded, all relevant settings and values can be adjusted.

### 12.2.3 General Settings

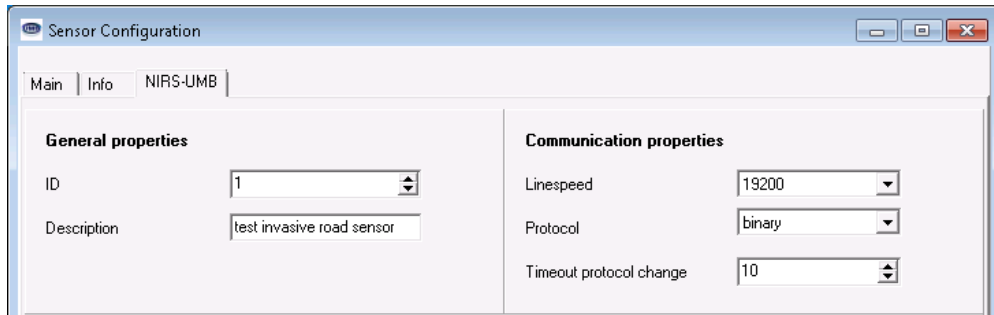

Fig. 13: General Settings

- ID:** Device ID (factory setting 1; assign device IDs to additional devices in ascending order).
- Description:** In order to differentiate the devices you can enter a description here, e.g. location.
- Linespeed:** Transmission speed of the RS485 interface (factory setting 19200; **DO NOT CHANGE for operation with ISOCON-UMB**).
- Protocol:** Sensor communications protocol (UMB-Binary, UMB-ASCII, SDI-12).
- Timeout:** In the event of a temporary changeover of the communications protocol, the system switches back to the configured protocol after this time (in minutes).



**Important note:** If the baud rate is changed, after saving the configuration on the sensor, the sensor communicates at the new baud rate. When operating the sensor in a UMB network with ISOCON-UMB, **this baud rate must not be changed**; otherwise the sensor is **no longer addressable** and can no longer be configured.

### 12.2.4 Device Settings

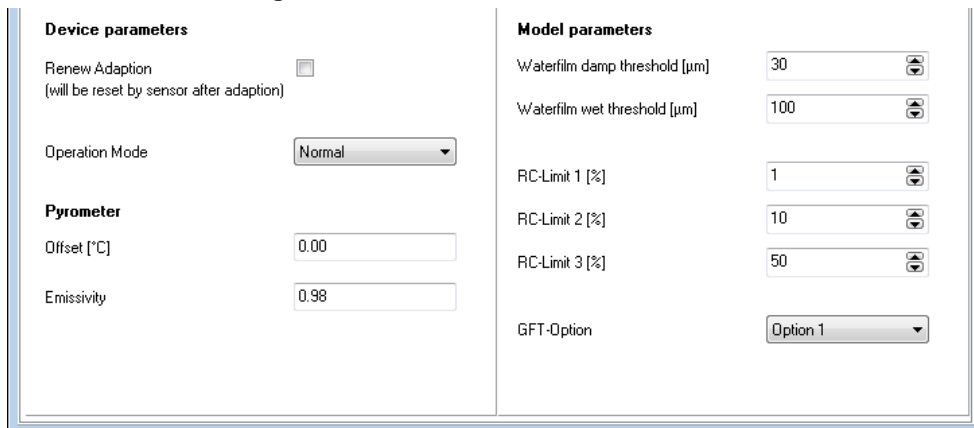

Fig. 14: Equipment Settings

- Renew Adaption:** The sensor performs a one-time new adjustment to the conditions prevailing at the installation.
- Operation Mode:** The general operation mode of the sensor. (see page 11)
- Offset:** Absolute offset of the road surface temperature measurement in °C.
- Emissivity:** Emissivity of the road surface for the temperature measurement; the default setting 0.95 is an average value for all road surface types.
- Waterfilm damp threshold:** The road condition "damp" is transmitted with effect from this water film height.  
**Note:** On polling the TLS channel the condition 32 is transmitted with effect from this threshold.
- Waterfilm wet threshold:** The road condition "wet" is transmitted with effect from this water film height.
- Other Parameters:** All other parameters should be changed only on the advice of the manufacturer.



### 12.3 Function Test with the UMB Config Tool

The function of the sensor can be tested with the UMB Config Tool by polling various channels.



**Note:** All other devices which are used in the polling process, e.g. modems, LCOM etc., must be disconnected from the UMB network during the function test.

#### 12.3.1 Channels for Measurement Polling

You can select the channel for measurement polling by the UMB Config Tool by clicking on the respective channel.

ChNr.	Measurement	Unit	Range	active
100	Act. road temperature	°C	-40.00 .. 70.00	active
101	Act. road temperature	°F	-40.00 .. 158.00	inactive
110	Act. freezing temp. NaCl	°C	-40.00 .. 0.00	inactive
111	Act. freezing temp. NaCl	°F	-40.00 .. 32.00	inactive
600	Act. waterfilm height	µm	0.00 .. 1000.00	active
605	Act. waterfilm height	mil	0.00 .. 39.37	inactive
900	Act. road condition	logic	0.00 .. 100.00	active
610	Act. snow height	mm	0.00 .. 100.00	inactive
800	Act. ice percentage	%	0.00 .. 100.00	inactive
810	Act. saline concent. NaCl	%	0.00 .. 0.00	inactive
1049	Act. road temperature	TLS FG3 DE 49	-300.00 .. 800.00	inactive
1070	Act. road condition	TLS FG3 DE 70	0.00 .. 255.00	inactive

Fig. 15: Measurement Polling Channels



**Note:** Channel selection relates to measurement polling for the UMB Config Tool only. In general, all channels are always available for polling and do not need to be enabled in the sensor.

#### 12.3.2 Example of Measurement Polling

NIRS31-UMB ID1 road temperature [°C] Act	NIRS31-UMB ID1 waterfilm height [µm] Act	NIRS31-UMB ID1 road condition [logic] Act
9.50	0.00	0.00
9.40	0.00	0.00
9.50	0.00	0.00
9.50	0.00	0.00

Fig. 16: Example of Measurement Polling



**Note:** The UMB Config Tool is provided for test and configuration purposes only. It is not suitable for the permanent acquisition of measurement data. We recommend the use of professional software solutions for this purpose, e.g. SmartView3.

### 13 Firmware Update

To keep the sensor in accordance with the latest state-of-the-art, it is possible to carry out a firmware update on site with no need to remove the sensor and return it to the manufacturer. The firmware update is carried out with the aid of the UMB Config Tool.

The description of the firmware update can be found in the instructions for the UMB Config Tool. Please download the latest firmware and UMB Config Tool from our website [www.lufft.com](http://www.lufft.com) and install it on a Windows® PC. You can find the instructions here:



## 14 Maintenance

The following are required for maintenance:

- Hexagon socket wrench, size 6
- Reflector unit (spare part)

Maintenance on the sensor must be performed in accordance with the indication 'Remaining Time to Next Service'; this is due approximately once every two years. The following work must be carried out:

- Replace the reflector unit
- Clean the transmitter and receiver plate
- Function test / renew Adaption



**Note:** Maintenance works must be performed by trained specialists only and in dry weather (no precipitation), as the housing has to be opened. Otherwise the equipment can be damaged due to the presence of moisture inside the unit.



**Important note:** When carrying out maintenance, the same conditions that are required for commissioning (see page 25) must be met and the instructions for commissioning must be observed, as a new adjustment of the sensor takes place automatically after maintenance.

### 14.1 Replacing the Reflector Unit

To replace the reflector unit it is necessary to open the device by loosening the two screws on the front.

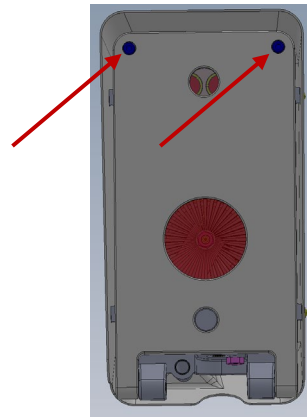

**Note:** Hold the front of the sensor while loosening the screws to ensure that the front of the sensor does not fall downwards.

Remove the reflector unit connection cable and the 3 retaining springs.

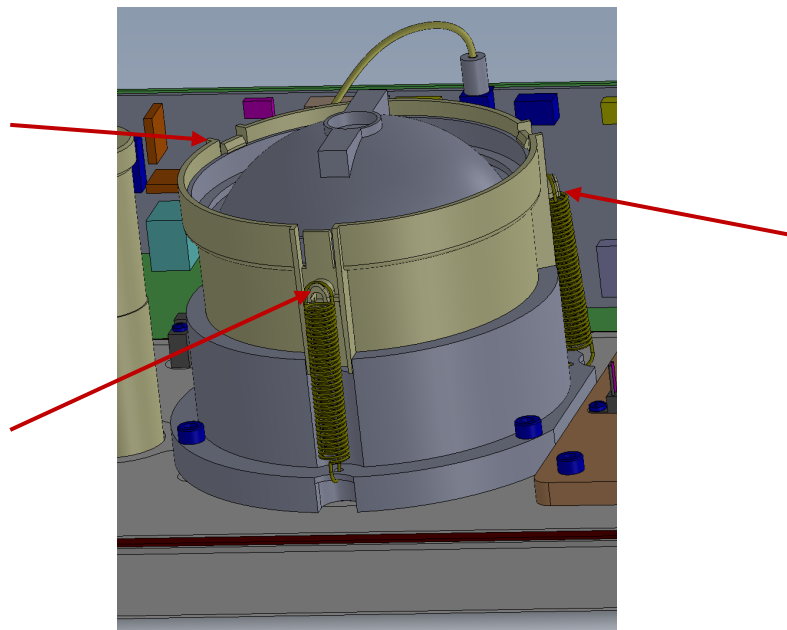

After that the reflector unit can be replaced.

Lock the new reflector unit into position with the retaining springs and plug the connection cable back into the main board.

After that, close the front and fix it again with the two screws.

Pay attention that no cable will be trapped while closing the front.

#### 14.2 Cleaning the Transmitter and Receiver Plates

If the transmitter and receiver plates are dirty, clean them with a damp, wrung out cloth. Then dry the plates with a dry, dust-free cloth.

Also remove any dust and dirt on the housing.

Do not use solvents such as benzene, thinner, alcohol, kitchen cleaners, etc. to clean the sensor as these can damage the housing and optical parts.

If you use a chemical cleaning cloth, please refer to the associated instructions.

#### 14.3 Resetting the Service Level

After carrying out maintenance and replacing the reflector unit, the sensor must be informed about this procedure using the UMB Config Tool.

In the menu under 'Options', select the entry 'NIRS31-UMB' → 'NIRS31-UMB Service':

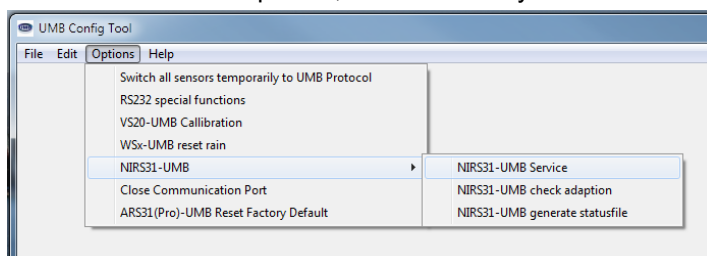

Confirm the performance of maintenance with 'OK'.

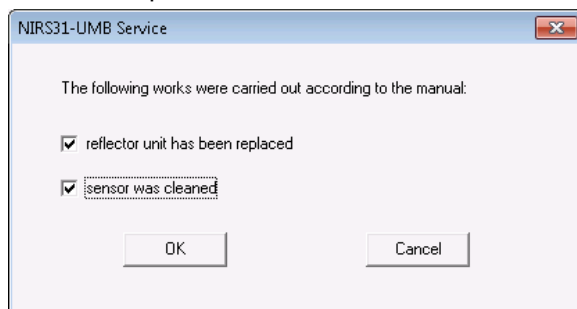

**Important note:** Only use this function if maintenance was actually carried out and the reflector unit was actually replaced.



**Important note:** When carrying out this function, the same conditions that are required for commissioning (see page 25) must be met and the instructions for commissioning must be observed, as a new adjustment of the sensor takes place automatically after maintenance.



#### 14.4 Function Test

To check the function of the sensor after maintenance, a function test must be performed as described in Section 12.3.

#### 14.5 Checking the Sensor Adjustment

Using the UMB Config Tool, the adjustment of the sensor can be checked. The following conditions must be met for the period of checking (10 minutes):

- Absolutely dry road
- No traffic jam on the road
- The last restart of the sensor must be at least 15 minutes ago

To verify the adjustment chose the menu "Options" → "NIRS31-UMB" → "NIRS31-UMB check adaption" in the UMB Config Tool.

Check the sensor ID and, if necessary, change it to the ID of the Sensor; then click the "Check Status" button:

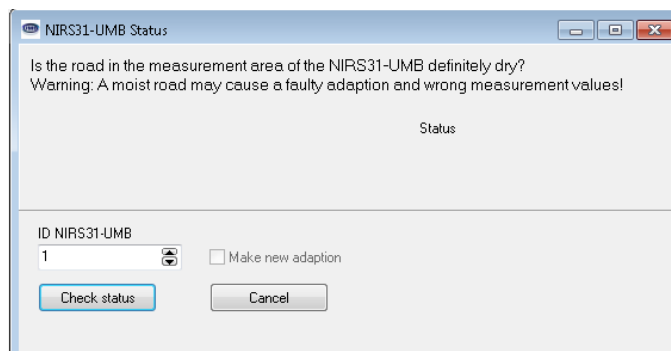

After the test, a message appears stating whether the adjustment is correct. If it's not, a new adaptation can be performed.

#### 14.6 Generate Status File

To generate a status file chose the menu "Options" → "NIRS31-UMB" → "NIRS31-UMB Generate Status File" in the UMB Config Tool.

Follow the instructions.

For further analysis of the sensor function, you can send this file, if it is necessary, to our hotline.

## 15 Technical Data

Power supply:	24 VDC +15 %/ -10 %
Nominal voltage supply:	24 VDC
Power input:	40 VA (15 VA in Energy Saving Mode)

Current consumption at nominal voltage:	approx. 1.65 A at 24 VDC
Inrush current:	approx. 32A (50µs) at 24 VDC



**Note: the current consumption increases depending of the cable length!**

E.g. with the 15 meter cable (8371.UK015):

Current consumption:	approx. 1.75 A
----------------------	----------------

Sensor dimensions:	Height 425 mm Width 225 mm Depth 285 mm
--------------------	---

Sensor weight:	approx. 9.9 kg
----------------	----------------

Mast bracket weight:	approx. 1.0 kg
----------------------	----------------

Fastening:	Mast bracket for Ø 60 - 76mm
------------	------------------------------

Protection class:	III (SELV)
-------------------	------------

Protection type:	IP65
------------------	------

### Storage conditions

Permissible storage temperature:	-40°C ... +70°C
----------------------------------	-----------------

Permissible relative humidity:	0 ... 95% R.H. non-condensing
--------------------------------	-------------------------------

### Operating conditions

Permissible ambient temperature:	-40°C ... +60°C
----------------------------------	-----------------

Permissible relative humidity:	0 ... 100% R.H.
--------------------------------	-----------------

Permissible altitude above sea level:	N/A
---------------------------------------	-----

### RS485 interface, 2 wire, half-duplex

Data bits:	8 (SDI-12 Mode: 7)
------------	--------------------

Stop bit:	1
-----------	---

Parity:	No (SDI-12 Mode: even)
---------	------------------------

Tri-state:	2 bits after stop bit edge
------------	----------------------------

Adjustable baud rates:	1200, 2400, 4800, 9600, 14400, 19200 <sup>1</sup> , 28800, 57600 (SDI-12 Mode: 1200 fixed)
------------------------	---

Housing:	Aluminium; plastic cover
----------	--------------------------

## 15.1 Measurement Range / Accuracy

### 15.1.1 Road Surface Temperature

Measurement process:	Pyrometer
Measuring range:	-40°C ... +70°C
Resolution:	0.1°C
Accuracy:	+/- 0.8°C
Sampling rate:	1 minute
Units:	°C; °F

### 15.1.2 Water Film Height

Measurement process:	Spectroscopic
Measuring range:	0 ... 2000 µm
Resolution:	0.01 µm
Accuracy:	+/- 0.1 mm +/- 20% of measurement
Sampling rate:	<1 minute
Units:	µm, mil

### 15.1.3 Ice Layer Thickness

Measurement process:	Spectroscopic
Measuring range:	0 ... 2000 µm
Resolution:	0.01 µm
Sampling rate:	<1 minute
Units:	µm, mil

### 15.1.4 Freezing Temperature

Measurement process:	Spectroscopic
Measuring range:	-40°C ... 0°C
Resolution:	0.1°C
Sampling rate:	<1 minute
Units:	°C; °F

### 15.1.5 Ice Percentage

Measurement process:	Spectroscopic
Measuring range:	0% ... 100%
Resolution:	0.1%
Sampling rate:	<1 minute
Units:	%

### 15.1.6 Saline Concentration

Measurement process:	Spectroscopic
Measuring range:	0% ... 100%
Resolution:	0.1%
Sampling rate:	<1 minute
Units:	%

### 15.1.7 Snow Height

Measurement process:	Spectroscopic
Measuring range:	0 ... 10mm
Resolution:	0.01mm
Sampling rate:	<1 minute
Units:	mm

### 15.1.8 Friction

Measurement process:	Spectroscopic
Measuring range:	0 ... 1
Resolution:	0.01
Sampling rate:	<1 minute

15.2 Drawings

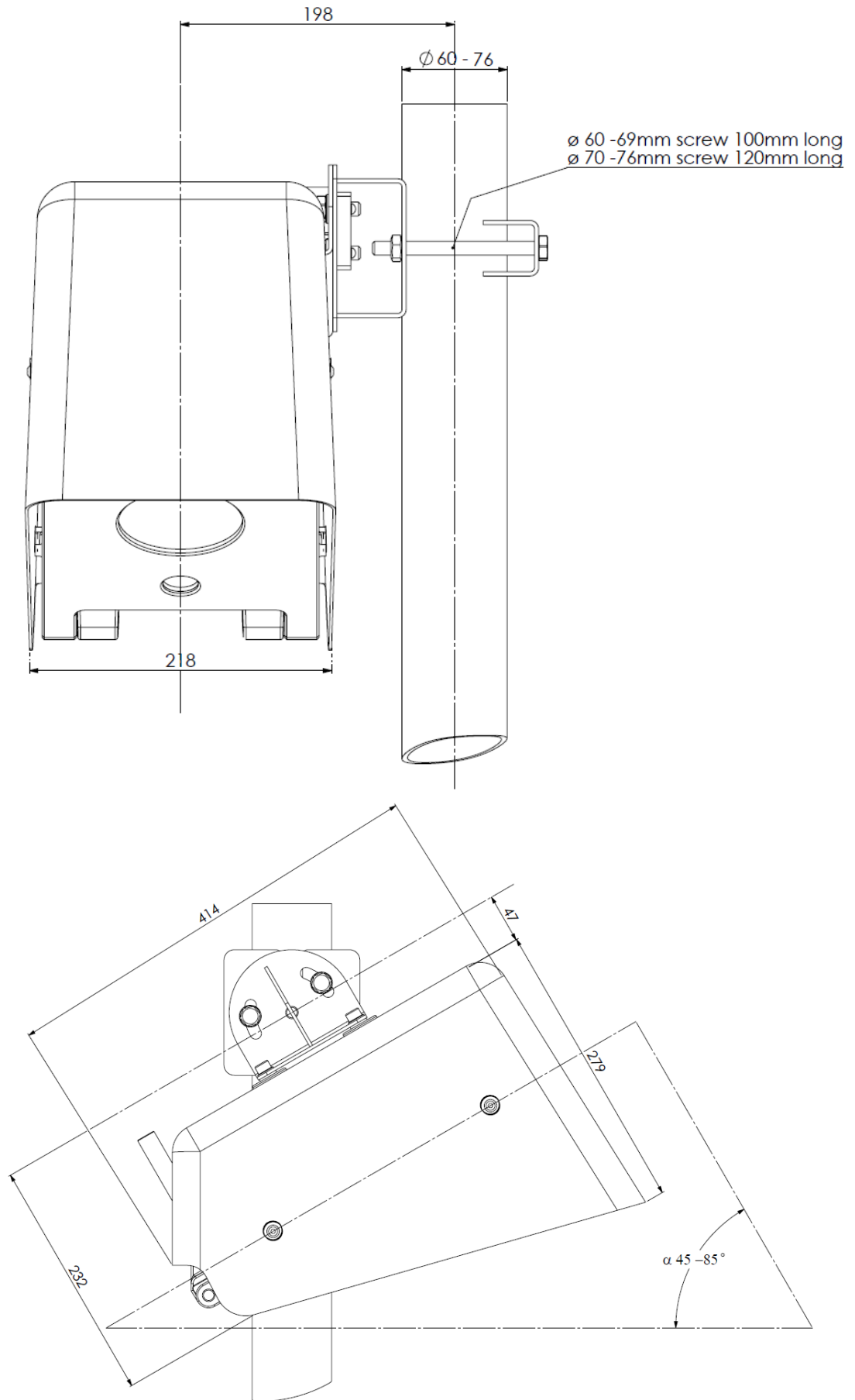

Fig. 17: NIRS31-UMB

## 16 Fault Description

Fault Description	Cause - Remedy
Device does not allow polling or does not respond	<ul style="list-style-type: none"> <li>- Check supply voltage</li> <li>- Check interface connection</li> <li>- Incorrect device ID →check ID; devices are delivered with ID 1.</li> </ul>
Device delivers implausible values	<ul style="list-style-type: none"> <li>- Check for compliance with the sensor installation instructions</li> <li>- Adaptation not suitable for the installation location →repeat the adaptation using the UMB Config Tool</li> </ul>
Device transmits error value 24h (36d)	A channel was requested that is not available on this device.
Device transmits error value 28h (40d)	Device is in initialization phase after start-up →wait until first measurement is complete.
Device transmits error value 50h (80d)	Device is being operated above the specified measuring range.
Device transmits error value 51h (81d)	Device is being operated below the specified measuring range.
Device transmits error value 55h (85d)	<p>The device is unable to execute a valid measurement due to the ambient conditions. This may be due to the following reasons:</p> <ul style="list-style-type: none"> <li>- in the measurement field stands a vehicle for a certain time e.g. traffic jam</li> </ul>
Device transmits an error value not listed here	There may be several reasons for this behaviour → contact the manufacturer's technical support service.

## 17 Disposal

### 17.1 Within the EC



The device must be disposed of in accordance with European Directives 2002/96/EC and 2003/108/EC (waste electrical and electronic equipment). Waste equipment must not be disposed of as household waste! For environmentally sound recycling and the disposal of your waste equipment please contact a certified electronic waste disposal company.

### 17.2 Outside the EC

Please comply with the applicable regulations for the proper disposal of waste electrical and electronic equipment in your respective country.

## 18 Repair / Corrective Maintenance

Please arrange for any faulty equipment to be checked and, if necessary, repaired by the manufacturer exclusively. Do not open the equipment and do not under any circumstances attempt to carry out your own repairs.

In matters of guarantee or repair please contact:

### **OTT HydroMet Fellbach GmbH**

Gutenbergstraße 20

70736 Fellbach

PO Box 4252

70719 Fellbach

Germany

Phone: +49 711 51822-0

Hotline: +49 711 51822-52

Fax: +49 711 51822-41

E-mail: [met-info@otthydromet.com](mailto:met-info@otthydromet.com)

Or your local distributor.

### 18.1 Technical Support

Our Hotline is available for technical questions via the following e-mail address:

[met-support@otthydromet.com](mailto:met-support@otthydromet.com)

You can also consult frequently asked questions at [www.lufft.com](http://www.lufft.com) (menu header: Support → FAQs).

## 19 Appendix

### 19.1 Channel List Summary

The channel assignment described here applies to online data requests in UMB protocol.

UMB Channel				Measurement Variable (float32)	Measuring Range		
act	min	max	avg		min	max	unit
<b>Road surface temperature</b>							
100				road temperature	-40.0	70.0	°C
101				road temperature	-40.0	158.0	°F
<b>Freezing temperature</b>							
110				freezing temp. NaCl	-40.0	0.0	°C
111				freezing temp. NaCl	-40.0	32.0	°F
<b>Water film height</b>							
600				water film height	0.0	2000.0	µm
605				water film height	0.0	393.7	mil
<b>Ice layer thickness</b>							
601				ice layer thickness	0.0	2000.0	µm
606				ice layer thickness	0.0	393.7	mil
<b>Snow height</b>							
610				snow height	0.0	10.0	mm
<b>Ice percentage</b>							
800				ice percentage	0.0	100.0	%
<b>Saline concentration</b>							
810				saline concent. NaCl	0.0	100.0	%
<b>Road condition</b>							
900				road condition (uint8)	0	Dry	
					1	Damp	
					2	Wet	
					3	Ice	
					4	Snow / ice	
					5	Chemically wet	
					6	Critically wet	
					8	Snow	
					99	Undefined	
<b>Friction</b>							
820				friction	0.0	1.0	none
910				road wather index (uint8)	0	normal road weather	
					1	bad road weather	
					2	very bad road weather	
<b>Service level</b>							
4000				service level	-500.0	100.0	%
<b>Remaining time to service</b>							
4001				rem. Time to service	-10000.0	10000.0	h
<b>Lamp Status</b>							
4002				lamp status	0	Lamp OK	
					1	Lamp faulty	
<b>Device Status</b>							
4003				measure status	See page 15		
4004				energy consumption ratio	0.0	100.0	%

## 19.2 Channel List Summary per TLS2002 FG3

The following channels are available specifically for data requests for further processing in TLS format. These channels are available in binary protocol only.

DE Type	UMB Channel	Meaning	Format	Range	Resolution	Coding
49	1049	Result message Road surface temperature FBT	16 bit	-30 ... +80°C	0.1°C	80.0 = 800d = 0320h 0.0 = 0d = 0000h -0.1 = -1d = FFFFh -30.0 = -300d = FED4h
52	1052	Result message Residual salt NaCl RS	8 bit	0 ... 100%	1%	0 = 0d = 00h 100 = 100d = 64h 255 = 255d = FFh
65	1065	Result message Freezing temperature NaCl GFT	16 bit	-30 ... 0°C	0.1°C	0.0 = 0d = 0000h -0.1 = -1d = FFFFh -30.0 = -300d = FED4h
70	1070	Result message Road surface state FBZ	8bit	0 ... 255		0 Road is completely dry and free of snow and ice. 32 Road is wet with liquid water / aqueous solution. 64 Road is covered with frozen water/ solid aqueous solution. 65 Road is covered with snow or slush. Mixture of liquid and frozen water or aqueous solution. 66 Road is covered with ice (solid, frozen water and frozen aqueous solution). 255 Sensor is unable to determine the state of the road surface due to the prevailing conditions.
72	1072	Result message Water film height WFD	16 bit	0.00...10.00 mm	0.01 mm	0 = 0d = 0000h 10.00 = 1000d = 03E8h 65535 = 65535d = FFFFh
75	1075	Result message Snow film height SFD	8 bit	0 ... 50 mm	1 mm	0 = 0d = 00h 50 = 50d = 32h 255 = 255d = FFh
76	1076	Result message Eis film height EFD	16 bit	0.00...2.00 mm	0.01 mm	0 = 0d = 0000h 2.00 = 200d = 00C8h 65535 = 65535d = FFFFh
77	1077	Result message Friction GR	8 Bit	0.00...1.00	0.01	0,00 = 0d = 00h 1,00 = 100d = 64h
79	1079	Result message Road surface state for winter services FZW	8 Bit	0 ... 255		0 Dry 16 Damp 32 Wet 48 Extremely Wet 64 Slippery
129	1129	Result message Ice percentage EP	8 Bit	0...100 %	1%	0 = 0d = 00h 100 = 100d = 64h 255 = 255d = FFh



### 19.3 Communication in Binary Protocol

Only one example of an online data request is described in this operating manual. Please refer to the current version of the UMB Protocol for all commands and the exact mode of operation of the protocol (available for download at [www.lufft.com](http://www.lufft.com)).



**Note:** Communication with the sensor takes place in accordance with the primary – secondary principle (the primary control and secondary data supplying unit), i.e. there may only be ONE primary requesting unit on a network.

#### 19.3.1 Framing

The data frame is constructed as follows:

1	2	3 - 4	5 - 6	7	8	9	10	11 ... (8 + len) optional	9 + len	10 + len 11 + len	12 + len
SOH	<ver>	<to>	<from>	<len>	STX	<cmd>	<verc>	<payload>	ETX	<cs>	EOT

- SOH            Control character for the start of a frame (01h); 1 byte
  - <ver>        Header version number, e.g.: V 1.0 →<ver> = 10h = 16d; 1 byte
  - <to>         Receiver address; 2 bytes
  - <from>       Sender address; 2 bytes
  - <len>        Number of data bytes between STX and ETX; 1 byte
  - STX          Control character for the start of payload transmission (02h); 1 byte
  - <cmd>        Command; 1 byte
  - <verc>       Version number of the command; 1 byte
  - <payload>    Data bytes; 0 – 210 bytes
  - ETX          Control character for the end of payload transmission (03h); 1 byte
  - <cs>         Check sum, 16 bit CRC; 2 bytes
  - EOT          Control character for the end of the frame (04h); 1 byte
- Control characters: SOH (01h), STX (02h), ETX (03h), EOT (04h).

#### 19.3.2 Addressing with Class and Device ID

Addressing takes place by way of a 16 bit address. This breaks down into a Class ID and a Device ID.

Address (2 bytes = 16 bit)				
Bits 15 – 12 (upper 4 bits)		Bits 11 – 8 (middle 4 bits)	Bits 7 – 0 (lower 8 bits)	
Class ID (0 to 15)		Reserve	Device ID (0 – 255)	
0	Broadcast		0	Broadcast
5	Non-Invasive Road Sensor		1 - 255	Available
15	Primary or control devices			

ID = 0 is provided as broadcast for classes and devices. Thus it is possible to transmit a broadcast on a specific class. However this only makes sense if there is only one device of this class on the bus; or in the case of a command, e.g. reset.

**19.3.3 Example for Creating Addresses**

If, for example, you want to address a NIRS31-UMB device with the device ID 001, this takes place as follows:

The class ID for the NIRS31-UMB is 5d = 5h

The device ID is e.g. 001d = 01h

Putting the class and device IDs together gives the address 5001h (20481d).

**19.3.4 Example of a Binary Protocol Request**

If, for example, a NIRS31-UMB device with the device ID 001 is to be polled from a PC for the current road surface temperature, this takes place as follows:

**Sensor:**

The class ID for the NIRS31-UMB is 5 = 5h

The device ID is 001 = 01h

Putting the class and device IDs together gives a target address of 5001h.

**PC:**

The class ID for the PC (primary unit) is 15 = Fh

The PC ID is e.g. 001d = 01h

Putting the class and device IDs together gives a sender address of F001h.

The length <len> for the online data request command is 4d = 04h

The command for the online data request is 23h

The version number of the command is 1.0 = 10h

The channel number is in <payload>; as can be seen from the channel list (page 39); the current road surface temperature in °C in the channel is 100d = 0064h.

The calculated CRC is 75D4h.

**The request to the device:**

SOH	<ver>	<to>		<from>		<len>	STX	<cmd>	<verc>	<channel>		ETX	<cs>		EOT
1	2	3	4	5	6	7	8	9	10	11	12	13	14	15	16
01h	10h	01h	50h	01h	F0h	04h	02h	23h	10h	64h	00h	03h	D4h	75h	04h

**The response from the device:**

SOH	<ver>	<to>		<from>		<len>	STX	<cmd>	<verc>	<status>	<channel>		<typ>
1	2	3	4	5	6	7	8	9	10	11	12	13	14
01h	10h	01h	F0h	01h	50h	0Ah	02h	23h	10h	00h	64h	00h	16h

<value>				ETX	<cs>			EOT
15	16	17	18	19	20	21	22	
8Fh	00h	45h	41h	03h	38h	B1h	04h	

**Interpretation of the response:**

<status> = 00h device o.k. (≠ 00h signifies error code; see page 43)

<typ> = Data type of the following value; 16h = float (4 bytes, IEEE format)

<value> = 4145008Fh corresponds to a float value of 1.23126E+0001 = 12.3

The road surface temperature is therefore 12.3°C.

Correct data transmission can be checked with the aid of the check sum (B138h).



**Note:** Little Endian (Intel, low byte first) applies when transmitting word and float variables of addresses or the CRC, for example. This means first the low byte and then the high byte.

### 19.3.5 Status and Error Codes in Binary Protocol

If a measurement request delivers the <status> 00h, the sensor is working correctly. You can find a complete list of additional codes in the description of the UMB protocol.

Extract from list:

<status>	Description
00h (0d)	Command successful; no error; all o.k.
10h (16d)	Unknown command; not supported by this device
11h (17d)	Invalid parameter
24h (36d)	Invalid channel
28h (40d)	Device not ready; e.g. initialization / calibration running
50h (80d)	Measurement variable (+offset) is outside the set display range
51h (81d)	
52h (82d)	Measurement value (physical) is outside the measuring range (e.g. ADC over range)
53h (83d)	
54h (84d)	Error in measurement data or no valid data available
55h (85d)	Device /sensor unable to carry out valid measurements due to ambient conditions

### 19.3.6 CRC Calculation

CRC is calculated according to the following rules:

Norm: CRC-CCITT

Polynomial: 1021h = x<sup>16</sup> + x<sup>12</sup> + x<sup>5</sup> + 1 (LSB first mode)

Start value: FFFFh

You can find further information in the description of a CRC calculation in the UMB Protocol.

### 19.3.7 Recording of a Communication with the UMB Config Tool

The UMB Config Tool uses the command 'Online data request multiple channels' (2Fh) for the data request.

Example of request to 3 channels (100, 600 and 900):

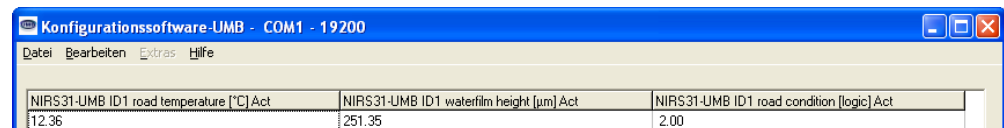

Communication (in hex):

Request by UMB Config Tool:

01 10 01 50 16 F0 09 02 2F 10 03 64 00 58 02 84 03 03 D4 FA 04

Response from NIRS31-UMB Sensor:

01 10 16 F0 01 50 1C 02 2F 10 00 03 08 00 64 00 16 8F C2 45 41 08 00 58 02  
16 9A 59 7B 43 05 00 84 03 10 02 03 28 A4 04

### 19.4 Communication in ASCII Protocol

Text-based communication with devices is possible using ASCII protocol.

To do this, in the device configuration, interface settings, the protocol mode must be set to ASCII (see page28).

ASCII protocol is network-compatible and serves exclusively for online data requests. The device will not respond to incomprehensible ASCII commands.



**Note:** The use of binary protocol is recommended for lengthy transmission routes (e.g. network, GPRS/UMTS), as ASCII protocol is unable to detect transmission errors (not CRC-secured).



**Note:** TLS channels are not available in ASCII protocol.

#### 19.4.1 Structure

An ASCII command is introduced by the '&' character and completed by the CR (0Dh) sign. There is a space character (20h) between the individual blocks in each case; this is represented by an underscore character '\_'. Characters that represent an ASCII value are in ordinary inverted commas.

#### 19.4.2 Summary of ASCII Commands

Command	Function	BC	AZ
M	Online data request		l
X	Switches to binary protocol		k
R	Triggers software reset	●	k
D	Software reset with delay	●	k
I	Device information		k

These operating instructions describe the online data request only. You can find the description of the other commands in the UMB protocol.

#### 19.4.3 Online Data Request (M)

**Description:** By way of this command, a measurement value is requested from a specific channel.

**Request:** '&'\_<ID><sup>5</sup>'\_M'\_<channel><sup>5</sup> CR

**Response:** '\$'\_<ID><sup>5</sup>'\_M'\_<channel><sup>5</sup>'\_<value><sup>5</sup> CR

<ID><sup>5</sup> Device address (5 decimal places with leading zeros)

<channel><sup>5</sup> Indicates the channel number (5 decimal places with leading zeros)

<value><sup>5</sup> Measurement value (5 decimal places with leading zeros); a measurement value standardized to 0 – 65520d. Various error codes are defined from 65521d – 65535d.

**Example:**

Request: &\_20481\_M\_00100

By way of this request, channel 100 of the device with address 20481 (NIRS31-UMB with device ID 001) is requested.

Response: \$\_20481\_M\_00100\_34785

This channel outputs a temperature from –40 to +70°C; this results in the following calculation:

0d corresponds to –40°C

65520d corresponds to +70°C

34785d corresponds to  $[+70^{\circ}\text{C} - (-40^{\circ}\text{C})] / 65520 * 34785 + (-40^{\circ}\text{C}) = 18.4^{\circ}\text{C}$

**Note:** TLS channels are not available in ASCII protocol.



#### 19.4.4 Standardization of Measurement Values in ASCII Protocol

The standardization of measurement values from 0d – 65520d corresponds to the measuring range of the respective measurement variable.

Measurement Variable	Measuring Range		
	min	max	unit
<b>Temperature</b>			
Road surface temperature	-40.0	70.0	°C
	-40.0	158.0	°F
Freezing temperature	-40.0	0.0	°C
	-40.0	32.0	°F
<b>Water film height</b>			
Water film height	0.0	2000.0	µm
<b>Snow depth</b>			
Snow depth	0.0	10.0	mm
<b>Percentage</b>			
Ice percentage	0.0	100.0	%
Saline concentration	0.0	100.0	%
<b>Friction</b>			
Friction	0.0	1.0	none

#### 19.4.5 Status and Error Codes in ASCII Protocol

Various error codes are defined from 65521d – 65535d in addition to the standardization of measurement values.

##### Codes:

<code>	Description
65521d	Invalid channel
65523d	Measurement value outside measuring range (too high)
65524d	Measurement value outside measuring range (too low)
65525d	Measurement data error or no valid data available
65526d	Device / sensor unable to execute valid measurement due to ambient conditions
65534d	Invalid calibration
65535d	Unknown error

## 19.5 Communication in SDI-12 Mode

The communication in SDI-12 mode of the NIRS31-UMB is conforming to the standard defined in 'SDI-12 A Serial-Digital Interface Standard for Microprocessor-Based Sensors Version 1.3 January 12, 2009'. The sensor may be operated in bus mode together with other SDI-12 sensors, connected to one SDI primary (logger).

### 19.5.1 Preconditions for SDI-12 Operation

As the interface settings defined in the SDI-12 standard are significantly different from the UMB default settings, some preconditions have to be met for operation:

- Setting for SDI-12 mode in the configuration with UMB Config Tool (at least V1.2)

Using the UMB Config Tool the protocol mode of the station has to be set to "SDI-12". This will automatically set the baud rate to 1200.

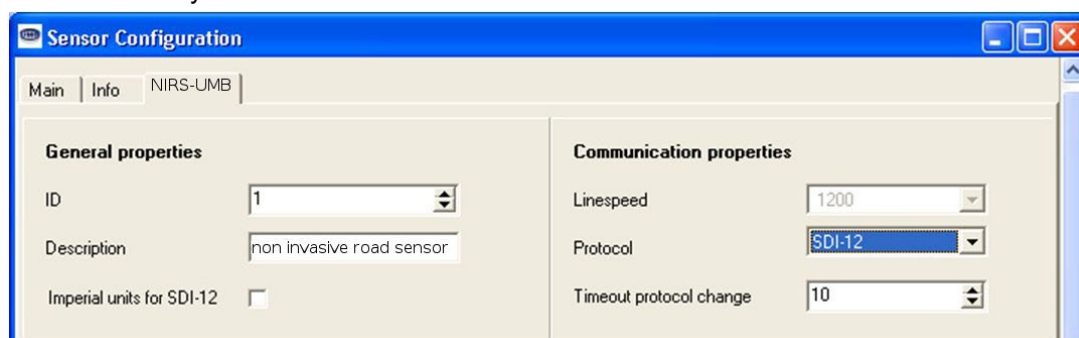

Measurement data can be transmitted alternatively in metric or US units. The selection is done by the UMB Config Tool.

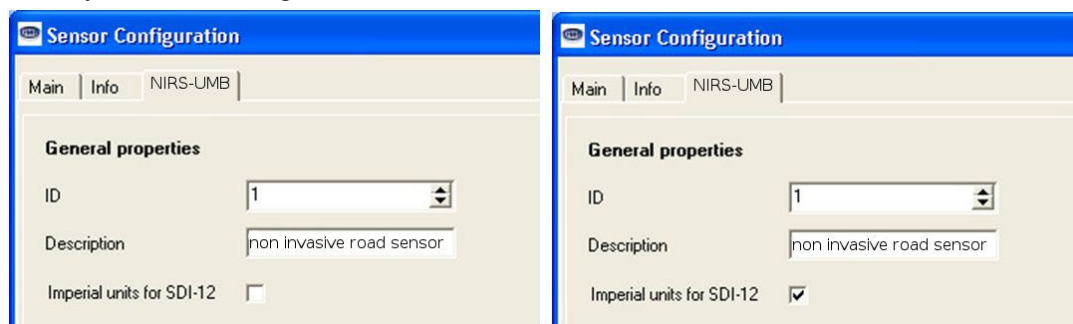

Metric units

US units

When operating the device in SDI-12 mode it is basically no more possible to access the device with the UMB Config Tool, due to the different interface parameter settings. To enable configuration access nevertheless the interface is operated in standard UMB mode (19200 8N1) for the first 5 seconds after reset / power on. If a valid UMB telegram is received within this time, the device will stay in UMB mode for the configured time out (several minutes) so that the configuration can be modified.

- Connect the PC to the NIRS31-UMB through an RS-485 converter (e.g. ISOCON)
- Start the UMB Config Tool and create a NIRS31-UMB with the address of the actual device and activate at least one sensor. Start the measurement (will report connection error at first)
- Reset the device (Power off / on)
- When measurement values are received the measurement can be terminated, the interface is now open for configuration.

### 19.5.2 Command Set

For details of the SDI-12 protocol please refer to the above mentioned standard document.

Following commands are available for the NIRS31-UMB:

**Note:** The examples in the following sections use italics to print the requests from the logger (*0V!*)



Command	Function
?!	Address search (Wildcard request, one device only on bus!)
a!	Request device active?
aI!	Request device identification
aAb!	Address change to b ( 0 ... 9, A ...Z, a ... z)
aM!	Measurement, basic data set
aMC!	Measurement, basic data set, transmit values with CRC
aC!	Concurrent measurement, basic data set
aCC!	Concurrent measurement, transmit values with CRC
aD0!	Data request buffer 0
aD1!	Data request buffer 1
aD2!	Data request buffer 2
aV!	Command verification: Evaluate sensor, data request with aD0!, aD1!
aXU<m/u>!	Change the unit system for SDI data
aXM+nnn!	Set device parameters: RC limit "Damp"
aXW+nnn!	Set device parameters: RC limit "Wet"
aX0+nn.n!	Set device parameters: Temperature offset pyrometer
aXE+n.nn!	Set device parameters: Road surface emissivity
aXRr!	Device reset
aXRa!	Device reset with renewal of adjustment
aXR <i>s!</i>	Device reset with reset of service level and renewal of adjustment

The composition of the basic data set depends on the variant (with / without pyrometer) of the actual device (see below).

Due to the applied measurement processes the NIRS31-UMB will, different from other sensors described in the SDI-12 document, always measure continuously. During certain phases of the measurement process the availability of the device for communication is limited. This causes some special properties:

- The device does not need a “Wakeup” and does not have a sleep mode. So the reactions to “Break” signals and any related timings are inapplicable. “Break” will be ignored by NIRS31-UMB.
- M- and C- commands only differ in the number of values made available in the buffers (in both cases up to the maximum permitted by the standards of 9 resp. 20).
- R-Commands are not available.



### 19.5.3 Address Configuration

UMB Device-ID and SDI-12 Address are related, but the different address ranges and the fact, that UMB ID's are integer numbers, while SDI-12 addresses are ASCII characters, have to be considered.

UMB Device ID1 (default) corresponds to SDI-12 Address '0' (SDI-12 default).

Valid Address Ranges:

UMB (dec)			SDI-12 (ASCII)		
1	to	10	'0'	to	'9'
18	to	43	'A'	to	'Z'
50	to	75	'a'	to	'z'

### 19.5.4 Data Messages

In the interest of simplified evaluation the assignment of measurement values to data buffers '0' ... '9' has been defined unified for all measurement commands. For this reason the responses to C-requests have been restricted to 35 characters, not using the 75 characters permitted for these requests

Currently buffers '0' to '3' are in use.

The buffer assignment depends on the device variant (with / without pyrometer). Buffers '1' to '3' are available only from devices with pyrometer.

If the measurement value is not available for some reason, e.g. sensor failure, this is indicated by a value of +999.0. or -999.9 The logger can then evaluate the reason of failure by a aV! verification request.

The following tables show the measurement values in the sequence they are arranged in the telegram (see example).

Depending on the configuration of the device the values will be transmitted in metric or US units.



**Note:** The configured system of units is not indicated in the data messages. The logger may request this setting with the I-command and adjust the evaluation of the data messages accordingly

Example: M Request

*0M!*

00009<CR><LF>

9 measurement values are available

*0D0!*

0+251.4+30.0+2<CR><LF>

Water film 251.4µm, ice percentage 30.0, road condition 2

*0D1!*

0+12.4-5.1<CR><LF>

Road surface temperature 12.4°C, freezing temperature -5.1°C

*0D2!*

0+3.4+25.3<CR><LF>

snow height 3.4mm, saline concentration 25.3%

*0D3!*

0+0.4+1<CR><LF>

friction 0,4, road weather index 1  
(values for illustration purposes only)

## Example: C Request

*0C!*

*000009<CR><LF>*

9 measurement values are available

*0D0!*

*0+251.4+30.0+2<CR><LF>*

Water film 251.4µm, ice percentage 30.0, road condition 2

*0D1!*

*0+12.4-5.1<CR><LF>*

Road surface temperature 12.4°C, freezing temperature -5.1°C

*0D2!*

*0+3.4+25.3<CR><LF>*

snow height 3.4mm, saline concentration 25.3%

*0D3!*

*0+0.4+1<CR><LF>*

friction 0,4, road weather index 1

(values for illustration purposes only)

19.5.4.1 Buffer assignment Basic Data Set

Device configured for measurement values in metric units:

Measurement value	UMB Channel	Min	Max	Unit
Buffer '0'				
Water film height	600	0.0	2000.0	µm
Ice percentage	800	0.0	100.0	%
Road condition	900	0	Dry	
		1	Damp	
		2	Wet	
		3	Ice	
		4	Snow / ice	
		5	Chemically wet	
		6	Critically wet	
		8	Snow	
		99	Undefined	
Buffer '1'				
Road surface temperature	100	-40.0	70.0	°C
Freezing temperature (NaCl)	110	-40.0	70.0	°C
Buffer '2'				
Snow height	610	0.0	10.0	mm
Saline concentration NaCl	810	0.0	100.0	%
Buffer '3'				
Friction	820	0.0	1.0	
Road Weather Index	910	0, 1, 2		Code

Device configured for measurement values in US units:

Measurement value	UMB Channel	Min	Max	Unit
Buffer '0'				
Water film height	600	0.0	2000.0	µm
Ice percentage	800	0.0	100.0	%
Road condition	900	0	Dry	
		1	Damp	
		2	Wet	
		3	Ice	
		4	Snow / ice	
		5	Chemically wet	
		6	Critically wet	
		8	Snow	
		99	Undefined	
Buffer '1'				
Road surface temperature	101	-40.0	150.0	°F
Freezing temperature (NaCl)	111	-40.0	32.0	°F
Buffer '2'				
Snow height	610	0.0	10.0	mm
Saline concentration NaCl	810	0.0	100.0	%
Buffer '3'				
Friction	820	0.0	1.0	
Road Weather Index	910	0, 1, 2		Code

### 19.5.5 Message Device Identification

The device responds to the identification request with following message (example for SDI-12 device address '0'):

*0I!*

013Lufft.NIRSxynnn

x: device type (P: with pyrometer, N: without pyrometer)

y: Metric / US units ( m = metric, u = US )

nnn: Software version

i.e. for a NIRS31-UMB with pyrometer, configured for US units:

*0I!*

013Lufft.deNIRSPu022

### 19.5.6 Message Verification

The command verification aV! is used to evaluate status information of the device. The device responds with

a0004<CR<LF>

to the request, i.e. 4 values are available in the buffers.

The first "measurement value", transmitted in buffer '0' contains the status information of the measurement channels.

The status data of the channels are assembled to form "fake measurement values", where each digit represents one status. See below for the coding of states.

Buffer '0'	
Status buffer '0': +nnnn	Pyrometer status: 0 = OK, other codes see below Lamp status: 0 = OK, 1 = failure Chopper speed status: 0 = OK, 1 = failure Chopper failure status: 0 = OK, 1 = failure, 2 = not yet started, 3 = starting
Filter failure status	0 = OK, otherwise failure
Buffer '1'	
Remaining time to service	-10000h ... +10000h
Service-Level	-500.0% ... 100.0%

Example (SDI-12 Address '0', chopper wheel starting, 4000h to service):

*0V!*

00004<CR><LF>

*0D0!*

0+0013+0<CR><LF>

*0D1!*

0+50.0+4000<CR><LF>

Sensor status codes:

Sensor status	Code
OK	0
UNGLTG_KANAL	1
E2_CAL_ERROR E2_CRC_KAL_ERR FLASH_CRC_ERR FLASH_WRITE_ERR FLASH_FLOAT_ERR	2
MEAS_ERROR	3
MEAS_UNABLE	4
INIT_ERROR	5
VALUE_OVERFLOW CHANNEL_OVERRANGE	6
VALUE_UNDERFLOW CHANNEL_UNDERRANGE	7
BUSY	8
other sensor status	9

#### 19.5.7 Message Change of Unit System

The command is used to change the unit system used for the SDI-12 data between metric and US units. It is implemented as manufacturer specific X command.

Command: aXU<u/m>!

Response: aU<u/m><CR><LF>

u: US units, m: metric units

Example: change to metric units, SDI-12 address '0'

0XUm!

0Um<CR><LF>

#### 19.5.8 Message: Setting of the Threshold for Road Condition "Damp"

If the water film height is above the threshold the road condition is identified as "damp".

Command: aXM+n!n!

n!n!: "damp" threshold in  $\mu\text{m}$  water film

Response: aXM+n!n!<CR><LF>

The response to the attempt of setting of an invalid value (1<threshold<100) is

aXMf<CR><LF>

Example: The "damp" threshold shall be set to 30 $\mu\text{m}$

0XM+30!

0XM+30<CR><LF>

**19.5.9 Message: Setting of the Threshold for Road Condition “Wet”**

If the water film height is above the threshold the road condition is identified as “wet”.

Command: aXW+nnnn!

nnnn: “wet” threshold in  $\mu\text{m}$  water film

Response: aXW+nnnn<CR><LF>

The response to the attempt of setting of an invalid value (30<threshold<500) is

aXWf<CR><LF>

Example: The “wet” limit shall be set to 200 $\mu\text{m}$

*0XW+200!*

*0XW+200<CR><LF>*

**19.5.10 Message: Setting of the Road Surface Temperature Offset**

The offset is used to calibrate the pyrometric temperature measurement.

Command: aX0<+/->nn.n!

nn.n: offset in  $^{\circ}\text{C}$

Response: aX0<+/->nn.n<CR><LF>

The response to the attempt of setting of an invalid value is

aX0f<CR><LF>

Example: The offset shall be set to -3.5 $^{\circ}\text{C}$

*0X0-3.5!*

*0X0-3.5<CR><LF>*

**19.5.11 Message: Setting of the Road Surface Emissivity**

The emissivity setting is used to calibrate the pyrometric temperature measurement.

Command: aXE+>n.nn!

nn.n: offset in  $^{\circ}\text{C}$

Response: aXE+n.nn<CR><LF>

The response to the attempt of setting of an invalid value is

aXEf<CR><LF>

Example: The emissivity shall be set to 0.97

*0XE+0.97!*

*0XE+0.97<CR><LF>*

**19.5.12 Message: Station Reset**

The command initiates a station reset.

Command: aXRr!

Response: aXRok<CR><LF>

The response is followed by the station reset, i.e. the station will be offline for a few seconds.

Example:

*0XRr!*

*0XRok<CR><LF>*

### 19.5.13 Message: Station Reset with Reset of Service Level and Lamp Operating Hours, Renew Adjustment

This command shall only be executed after replacement of the lamp unit. It clears service level and lamp operating hours, then initiates a station reset. After the reset a new automatic adjustment will be executed.



**Important note:** For the automatic adjustment, the same conditions that are required for commissioning (see page 25) must be met and the instructions for commissioning must be observed, otherwise the new adjustment of the sensor cannot be completed successfully.

Command: aXRa!

Response: aXRok<CR><LF>

The response is followed by the station reset, i.e. the station will be offline for a few seconds.

Example:

*aXRa!*

aXRok<CR><LF>

### 19.5.14 Message: Station Reset with New Adjustment

This command initiates a station reset. After the reset a new automatic adjustment will be executed.



**Important note:** For the automatic adjustment, the same conditions that are required for commissioning (see page 25) must be met and the instructions for commissioning must be observed, otherwise the new adjustment of the sensor cannot be completed successfully.

Command: aXRa!

Response: aXRok<CR><LF>

The response is followed by the station reset, i.e. the station will be offline for a few seconds.

Example:

*aXRa!*

aXRok<CR><LF>

