

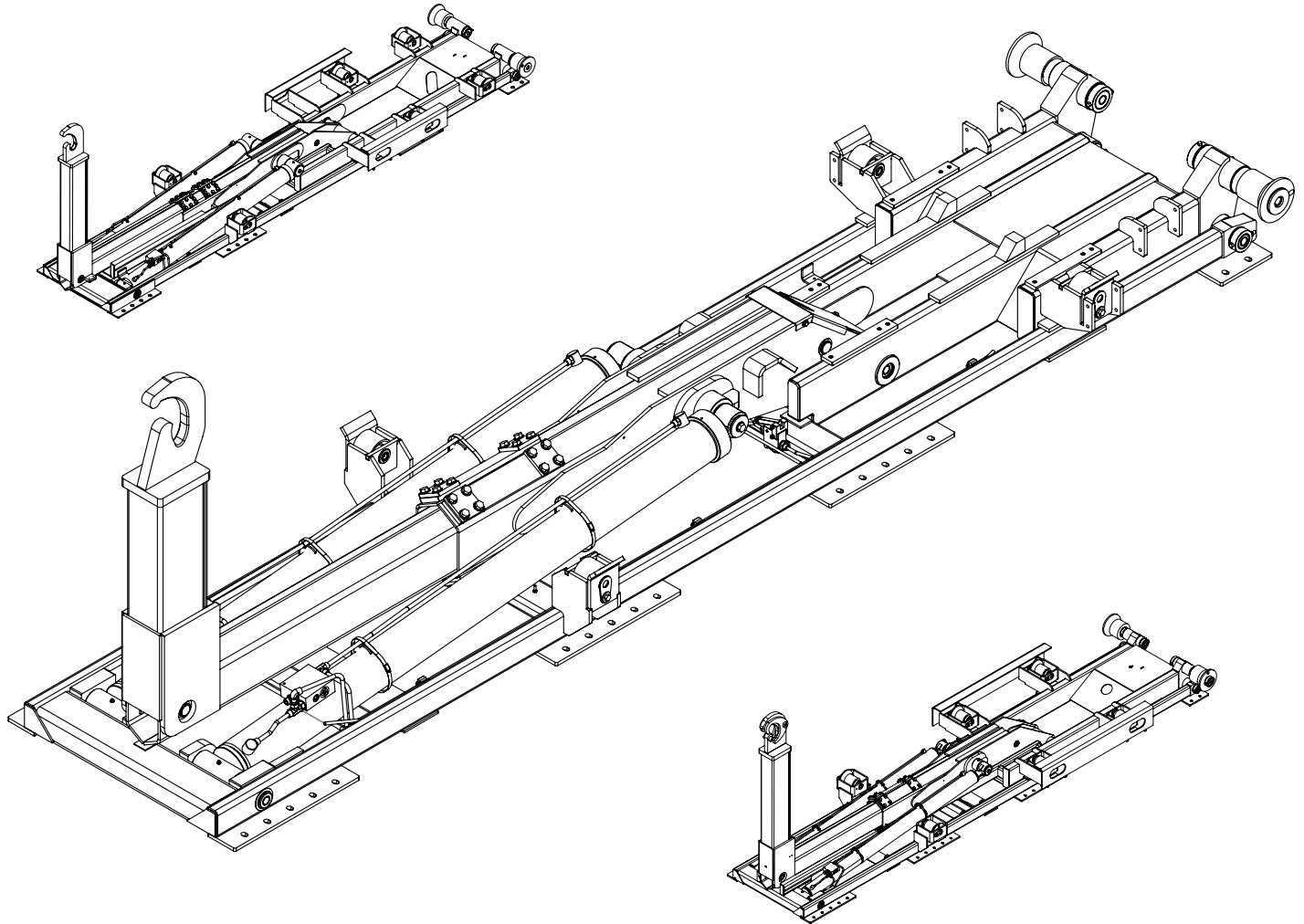

Slider Hooklift Owner's Manual

Safety • Operation • Maintenance • Troubleshooting



Stellar Industries, Inc.

190 State Street

PO Box 169

Garner, IA 50438

800-321-3741

Fax: 641-923-2811

www.stellarindustries.com

Subject to Change without Notification.
© 2022 Stellar Industries, Inc.

Rev 1
PN 89392

Slider Hooklift Manual Revisions

Date of Revision	Section Revised	Description of Revision

▲WARNING Operating, maintaining, and servicing a Stellar product may expose you to chemicals including, but not limited to, engine exhaust, carbon monoxide, phthalates, and lead. These chemicals are known to the State of California to cause cancer and birth defects (or other reproductive harm). To keep your exposure to a minimum, be sure to avoid breathing exhaust and service your Stellar product in a well-ventilated area while wearing gloves or washing your hands frequently. For more information, go to www.P65Warnings.ca.gov/passenger-vehicle.

Table of Contents

Introduction	iv
Hooklift Nomenclature	v
Chapter 1 - Operation	1
General Operation	1
Operator Requirements.....	1
Pre-Operation Inspection.....	2
Job Site Setup.....	2
Hooklift Controls.....	3
Hydraulic Hook Height Adjustment - Raise.....	4
Hydraulic Hook Height Adjustment - Lower	4
Manual Hook Height Adjustment - Raise.....	5
Manual Hook Height Adjustment - Lower	5
Loading Operation	6
Unloading Operation.....	9
Unloading Operation Continued.....	10
Dumping Operation.....	11
Safety Decals of Note.....	12
Chapter 2 - Maintenance.....	15
Basic Hooklift Inspection Schedule	15
General Maintenance Guidelines	16
Hydraulic Oil/Filter Maintenance	16
PTO and Pump Maintenance.....	17
Grease Zerk Locations	17
Choice Lubricants for DX Bearings.....	18
Chapter 3 - Troubleshooting.....	19
Serial Tag Location.....	19
General Troubleshooting.....	20
Dump Latch System Procedure.....	21

**For Technical Questions, Information, Parts, or Warranty, Call Toll-Free at
800-321-3741**

Hours: Monday - Friday, 8:00 a.m. - 5:00 p.m. CST

Or email at the following addresses:

Technical Questions, and Information

service@stellarindustries.com

Order Parts

parts@stellarindustries.com

Warranty Information

warranty@stellarindustries.com

Introduction

Stellar® Hooklifts are designed to provide safe and dependable service for a variety of operations. With proper use and maintenance, these hooklifts will operate at peak performance for many years.

To promote this longevity, carefully study the information contained in this manual before putting the equipment into service. Though it is not intended to be a training manual for beginners, this manual should provide solid guidelines for the safe and proper usage of the hooklift.

Once you feel comfortable with the material contained in this manual, strive to exercise your knowledge as you safely operate and maintain the hooklift. This process is vital to the proper use of the unit.

A few notes on this manual:

A copy of this manual is provided with every hooklift and can be found in the hard plastic manual case that is installed on the chassis. A copy of this manual shall remain with the hooklift at all times.

Throughout the manual, three signal words will be used to bring attention to important items:

NOTICE

A NOTICE signal word indicates a practice not related to physical injury.

⚠ WARNING

A WARNING signal word indicates a hazardous situation which, if not avoided, could result in death or serious injury.

⚠ DANGER

A DANGER signal word indicates a hazardous situation which, if not avoided, will result in death or serious injury.

Information contained within this manual does not cover all maintenance, operating, or repair instructions pertinent to all possible situations. Please be aware that some sections of this manual contain information pertaining to Stellar® manufactured hooklifts in general and may or may not apply to your specific model.

This manual is not binding. Stellar Industries, Inc. reserves the right to change, at any time, any or all of the items, components, and parts deemed necessary for product improvement or commercial/production purposes. This right is kept with no requirement or obligation for immediate mandatory updating of this manual.

In closing:

If more information is required or technical assistance is needed, or if you feel that any part of this manual is unclear or incorrect, please contact the Stellar Customer Service Department by phone at 800-321-3741 or email at service@stellarindustries.com.

Hooklift Nomenclature

The Stellar® Slider is a hydraulic, body-loading device when mounted on a truck chassis. It can handle a multitude of bodies ranging from flatbeds to recycling containers and dump bodies.

The Slider consists of four basic parts: the base, dump, secondary, and jib sections. Please take the time to familiarize yourself with the various components. Knowing the proper terminology is necessary to get the full benefit of this manual.

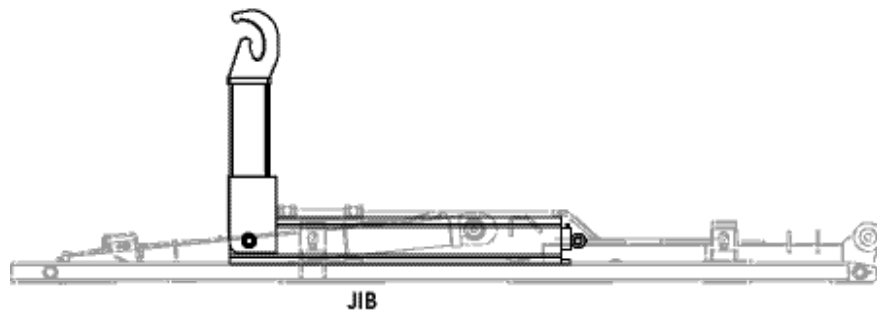
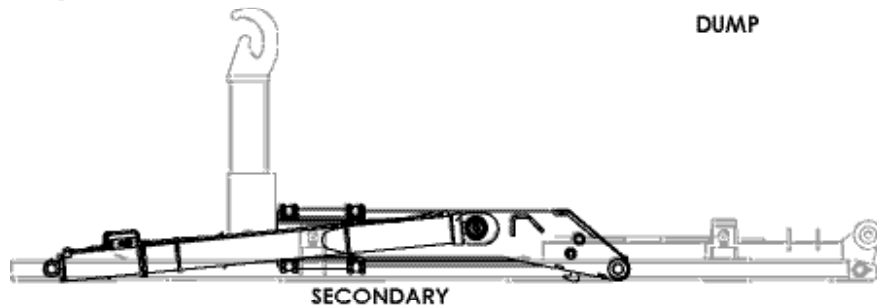
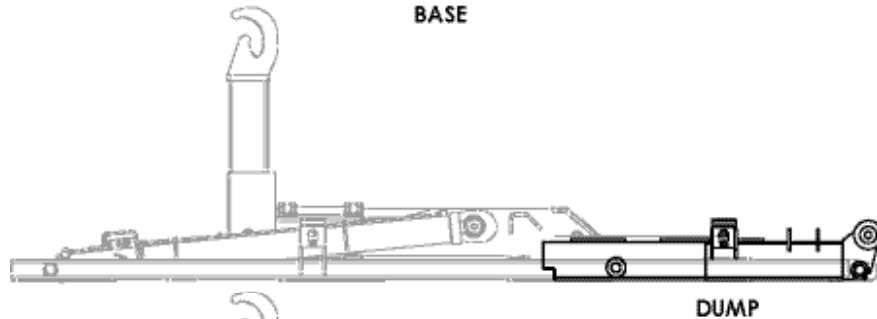
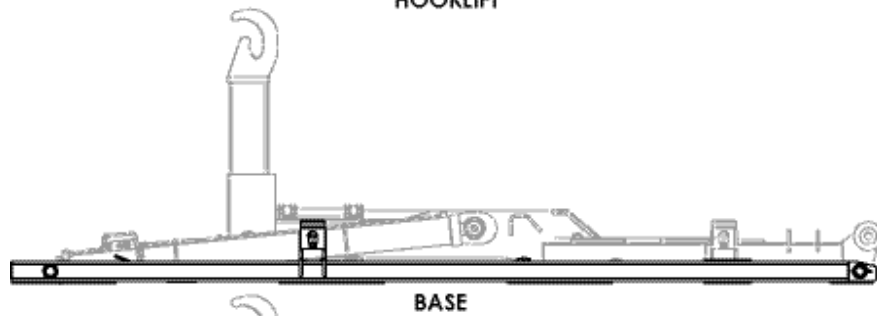
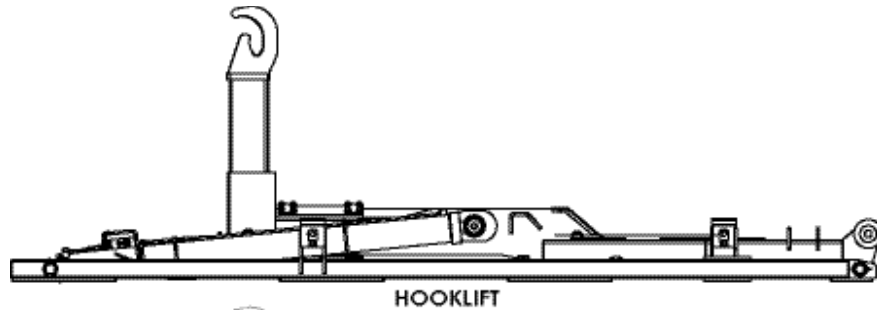

P65 Warning & Cold Weather Notice

NOTICE

Although clear data on cold weather performance from every steel manufacturer is not available for all types and thicknesses of steel, Stellar Industries is confident that the weldments on our products will operate to 100% of their intended purpose to temperatures down to -40° F / C.

It is recommended if Stellar manufactured equipment needs to be used in temperatures below -40° F / C, the operator should pull the unit into a climate-controlled area and allow the weldments to warm up to and then maintain a temperature above this level.

WARNING

Operating, maintaining, and servicing a Stellar product may expose you to chemicals including, but not limited to, engine exhaust, carbon monoxide, phthalates, and lead. These chemicals are known to the State of California to cause cancer and birth defects (or other reproductive harm). To keep your exposure to a minimum, be sure to avoid breathing exhaust and service your Stellar product in a well-ventilated area while wearing gloves or washing your hands frequently. For more information, go to www.P65Warnings.ca.gov/passenger-vehicle.

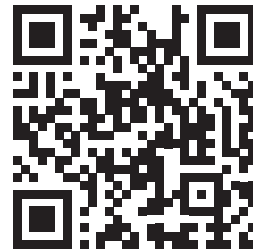

www.p65/warning.ca.gov

Chapter 1 - Operation

Safety should be the number one thought on every operator's mind. Three factors should exist for safe operation: a qualified operator, well-maintained equipment, and the proper use of this equipment.

This chapter contains information regarding the safety and operation of Stellar® manufactured Hooklifts and should be read and understood completely by everyone working with or near the hooklift before putting the unit into operation.

⚠ WARNING Failure to follow operating, maintenance, or safety instructions can result in death or serious injury.

General Operation

It is the responsibility of the owner to instruct the operator in the safe operation of the equipment and to provide the operator with properly maintained equipment.

⚠ WARNING Stellar® Hooklift operators must conform to the qualifications specified in this manual. Trainees or untrained persons shall be under the direct supervision of qualified persons.

Operators shall consult with the owner of the equipment regarding current safety regulations and required personal protective equipment.

Operators should never operate the hooklift while under the adverse influence of alcohol, drugs, or medication.

Please take note that Stellar Industries, Inc. is not liable for accidents incurred by the hooklift because of non-fulfillment from the operator's side of current rules, laws, and regulations.

Operator Requirements

Operation is limited to the following people:

- A. Qualified individual.
- B. Trainees under direct supervision of the qualified individual.
- C. Test or maintenance individual.
- D. Hooklift Inspector.

Qualified individuals must:

- A. Demonstrate the ability to understand all decals, the owner's manual, and any other information required for safe operation of the hooklift.
- B. Be able to demonstrate the ability to safely control the hooklift.
- C. Know all safety regulations.
- D. Be responsible for maintenance requirements.
- E. Understand and be fully capable of implementing all emergency procedures.
- F. Understand all operating procedures as outlined by this manual.

Pre-Operation Inspection

Before operating the equipment, make sure all regular maintenance has been performed. Each day, inspect the hooklift for all of the following:

- Hydraulic reservoir oil level.
- Hydraulic hoses and tubing for evidence of damage such as blistering, crushing, or abrasion.
- All safety covers for proper installation.
- Equipment for missing, illegible, or defaced operating decals and safety signs.
- Structural weldments for bends, cracks, or breaks
- All pins and keepers for proper installation
- Presence of this owner's manual
- All pins, bushings, shafts, and gears for wear, cracks, or distortion to include all pivot points, and bushings
- Replace/repair as necessary prior to operation.

Job Site Setup

Thoroughly plan the lift by understanding the work site area and your loads before positioning the vehicle. Consider the following:

- Know the weight of your load to avoid overloading the equipment. Deduct the weight of the body from the maximum load rating to determine how much weight can be lifted.
- Only use the hooklift to lift Stellar approved skids, bodies, or containers.
- **⚠ WARNING** Do not overload the hooklift. Never exceed manufacturer's load ratings. These ratings are based on the machine's hydraulic, mechanical, and structural design rather than stability. Know the hooklift components and their capabilities and limitations. Overloading the hooklift may result in serious damage of self, others, equipment or the surroundings.
- **⚠ WARNING** Do not allow unauthorized personnel or equipment to enter within 10 feet of hooklift operating area. The vehicle should be positioned in an area free from bystanders and overhead obstructions. Use a signal person if necessary.
- **⚠ DANGER** Always maintain safe clearance from high voltage power lines. Death or serious injury will result from inadequate clearance if hooklift, load, or vehicle becomes electrically charged.
- Make certain that the vehicle is parked on stable, flat ground as close to the job as possible. The surface under the service truck must be able to support the weight of the machine and its load. Take care when operating in areas supported by vehicle tires, because of the cushioning effect of springs and tires.
- **⚠ WARNING** Do not operate the hooklift during electrical storms.
- In dusty work areas, every effort must be taken to keep dust and sand out of the moving parts of the machinery.
- In high humidity work areas, keep parts as dry as possible and well lubricated.

Hooklift Controls

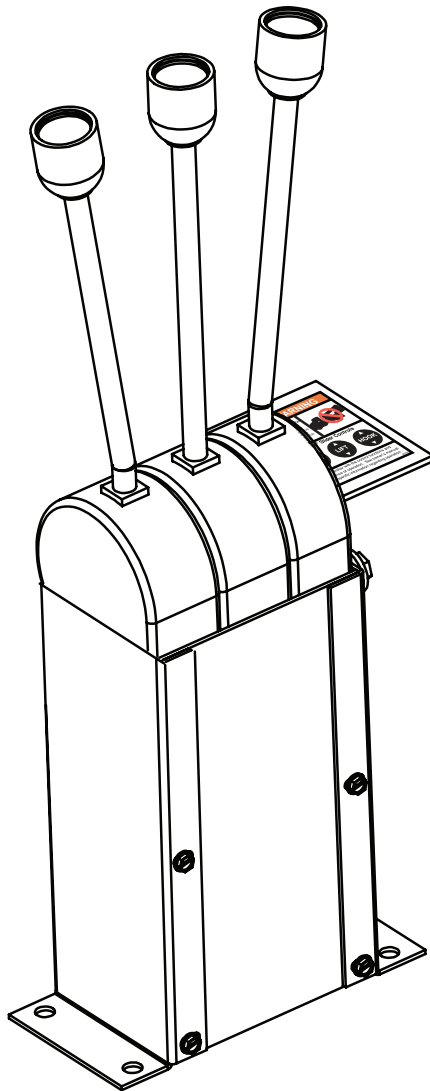

! WARNING

Misuse Hazard
Do not attempt to load container unless hook and bail heights match. Failure to match hook and bail heights can result in death or serious injury.



55755 - Rev A

Stellar® Slider Controls

SLIDE **LIFT** **HOOK**

Be familiar with the control functions and sequence of operation. See owner's manual for specific information regarding operation.

Be familiar with the sequence and operation of the hooklift controls.

Each individual hooklift function should have control function decals. Replace them immediately if they are missing or illegible.

Keep hands, feet and control levers free from mud, grease and oil.

Be familiar with the control levers and how they operate before attempting to operate the hooklift.

Move the control lever slow and smooth for steady oil flow. Avoid jerky or sudden movement of the controls.

Be constantly aware of the hooklift position when operating the controls.

In extreme cold, operate the controls slowly to allow for viscosity changes.

Hydraulic Hook Height Adjustment - Raise

With the hooklift in the stowed position without a body, put the truck in neutral and engage the PTO.

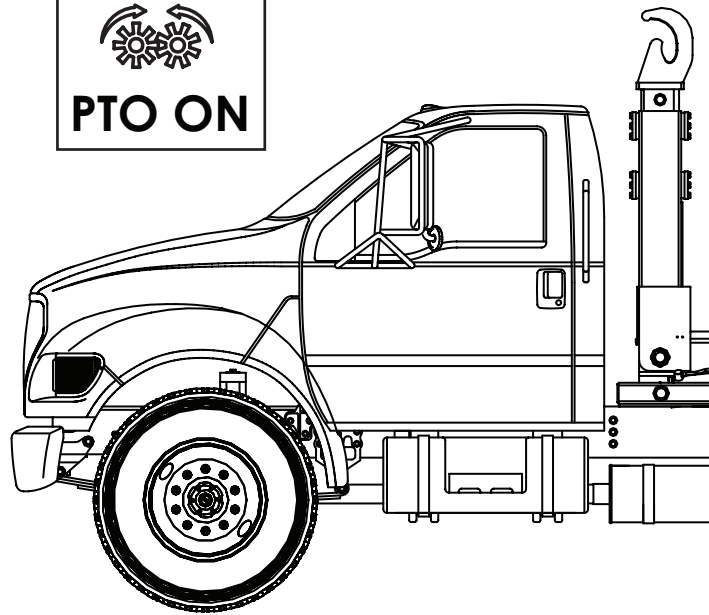

Pull the control lever labeled 'hook' to raise the hook height. When raised completely, release the lever and disengage the PTO.

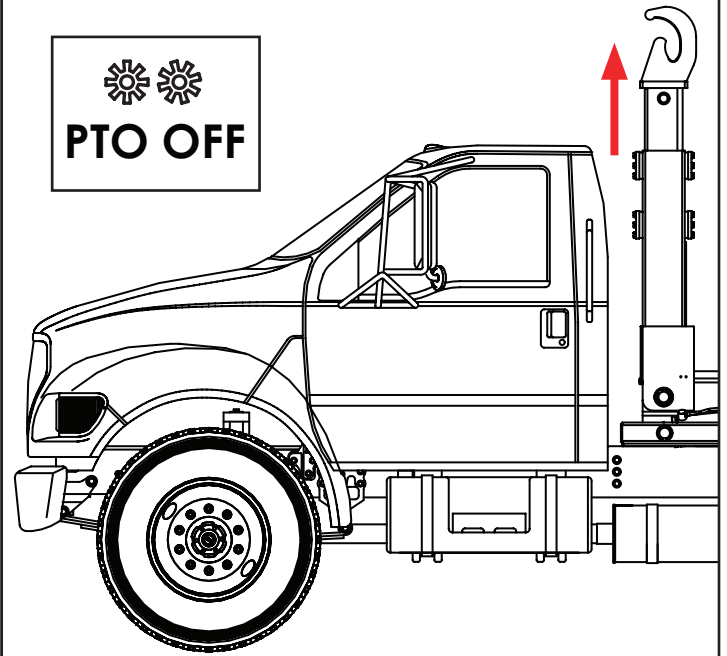

Hydraulic Hook Height Adjustment - Lower

With the hooklift in the stowed position without a body, put the truck in neutral and engage the PTO.

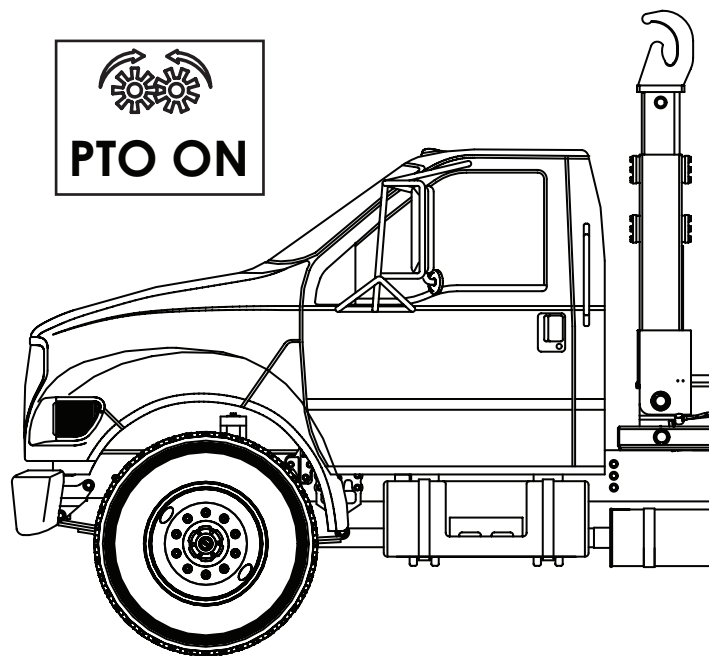

Push the control lever labeled 'hook' to lower the hook height. When lowered completely, release the lever and disengage the PTO.

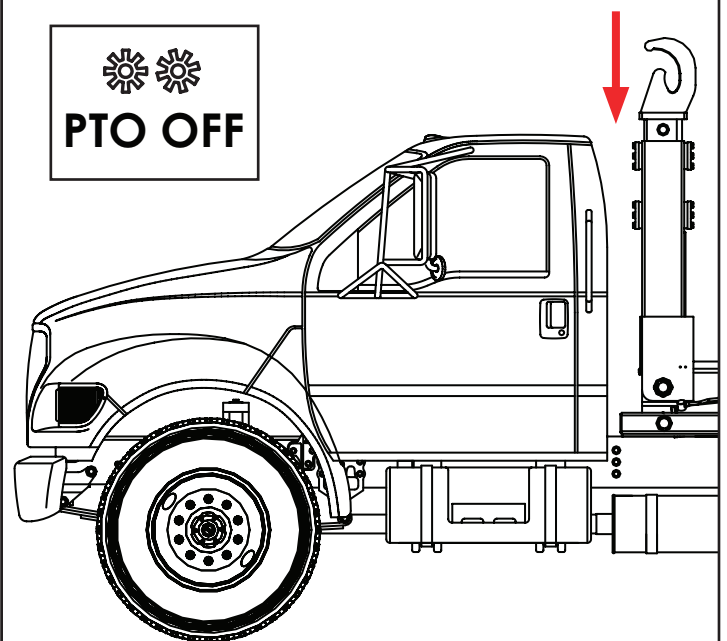

Manual Hook Height Adjustment - Raise

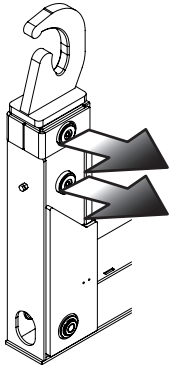

Step 1

Attach overhead hoist or lifting device to the hook.

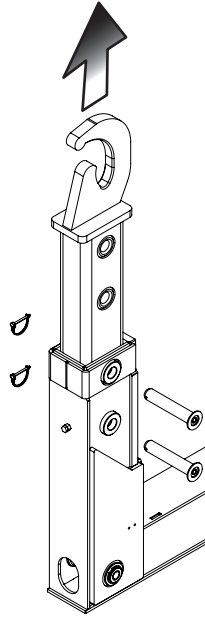

Step 2

Remove small keeper pins and large pins. Raise hook.

NOTE: Inspect pins for wear or damage. Replace if necessary.

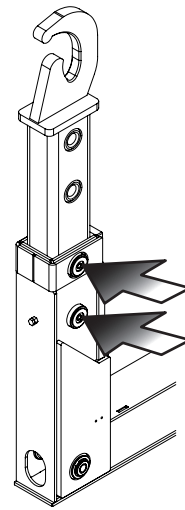

Step 3

Reinstall large pins and small keeper pins. Remove overhead hoist or lifting device.

Manual Hook Height Adjustment - Lower

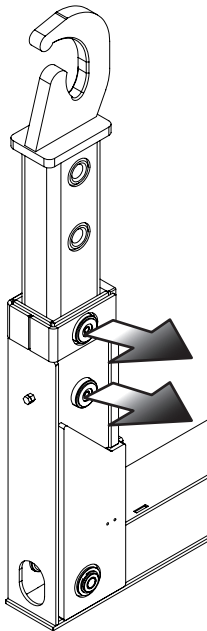

Step 1

Attach overhead hoist or lifting device to the hook.

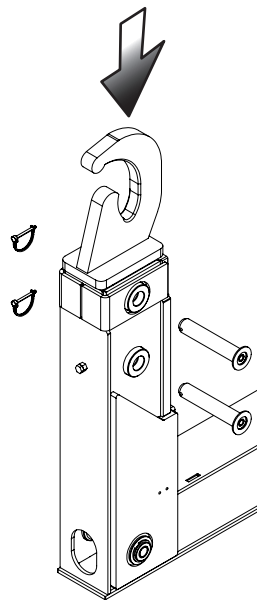

Step 2

Remove small keeper pins and large pins. Lower hook.

NOTE: Inspect pins for wear or damage. Replace if necessary.

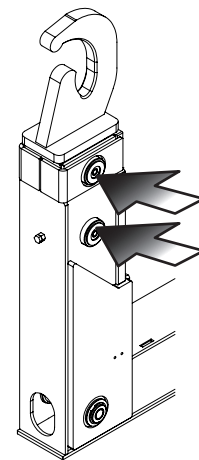

Step 3

Reinstall large pins and small keeper pins. Remove overhead hoist or lifting device.

Loading Operation

Note: Hook and bail heights must match.

Maneuver the truck into a position to load the body. Put the truck in neutral and engage the PTO.

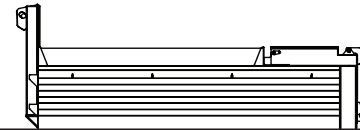
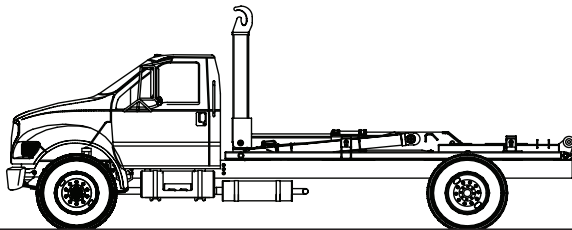

Pull the control lever labeled 'Jib' to slide the jib as far back as it will go, effectively releasing the dump latches. For info on the Slider20-S and Slider 26 models, see note below.

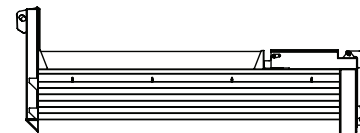
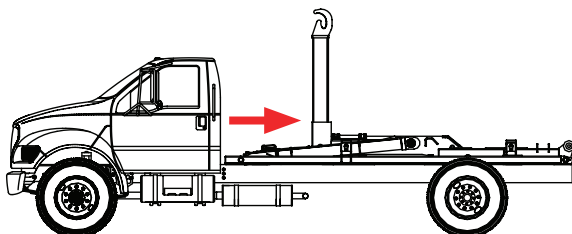

NOTE: To prevent activation of the replaceable dump tab bolt, it is important to allow the jib retract function to sequence for 1-2 seconds after the jib has fully retracted before activating the main lift function. This action ensures the automatic sequence system for the latch has fully disengaged. Image below shows dump latch disengaged:

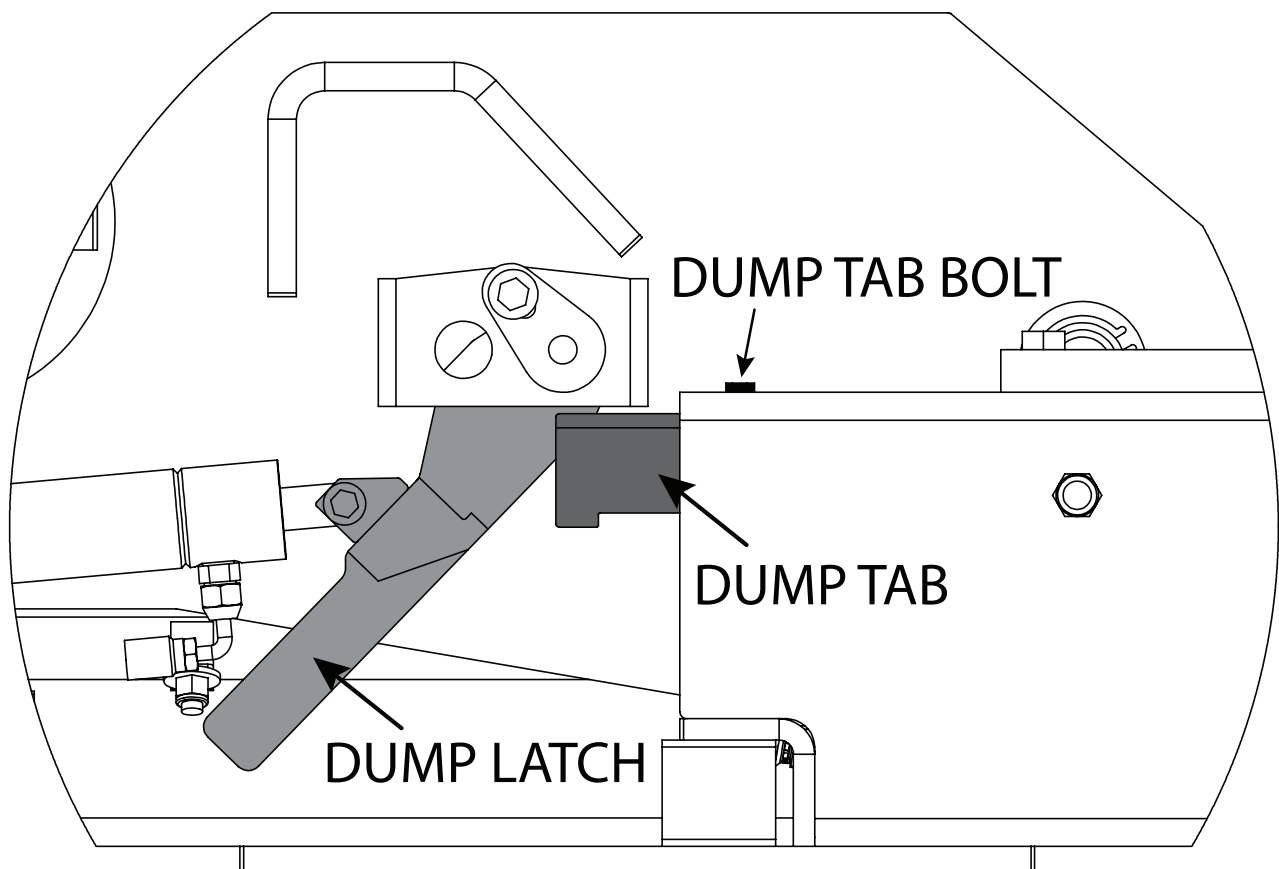

Loading Operation Continued...

Pull the control lever labeled 'Lift' until the hook is in a position to attach to the body.

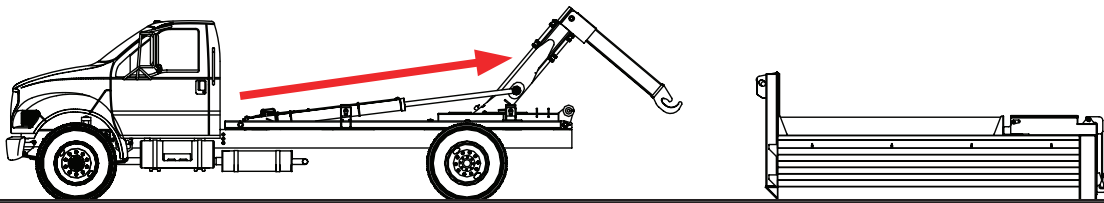
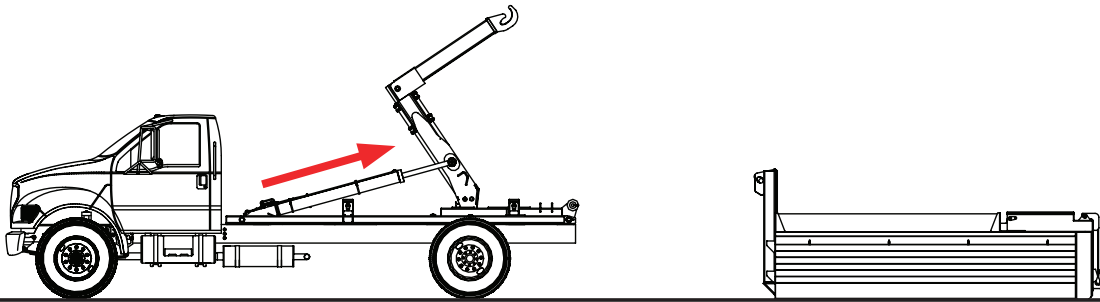

Slowly back up and attach to the body by using the 'Lift' control lever as necessary.

⚠ WARNING

Make certain that the hook is engaged around the hook bar before loading.

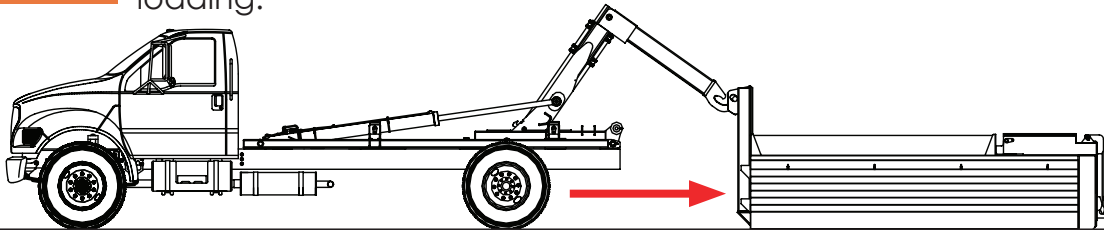

Loading Operation Continued...

Note: Hook and bail heights must match.

Once fully attached, push the 'Lift' control lever to load the body.

NOTICE

Never use the drivetrain of the chassis to assist the hydraulics in loading

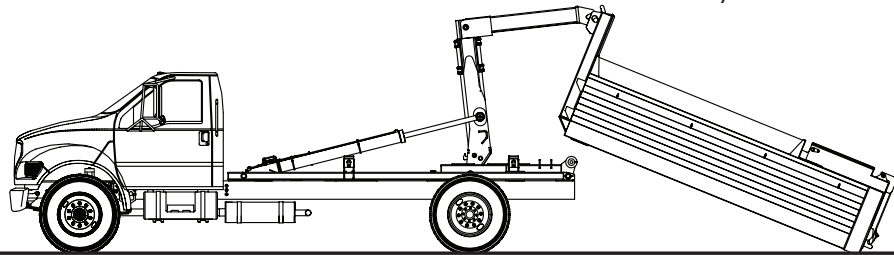

NOTICE

Make sure the body is lining up with the rear rollers while loading. If the container will experience a significant restriction to movement during loading, the foot brake must not be used. Allow the truck to roll under the load.

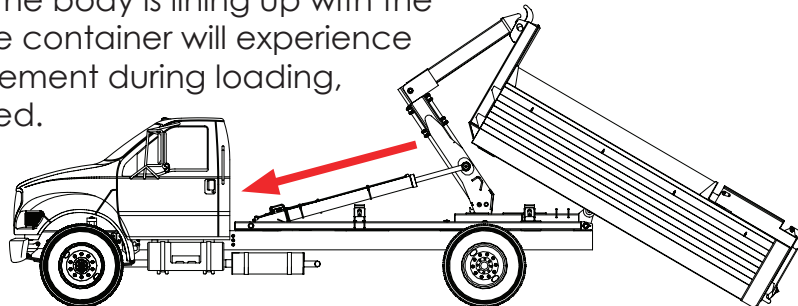

WARNING

Do not leave hooklift unattended with suspended load.

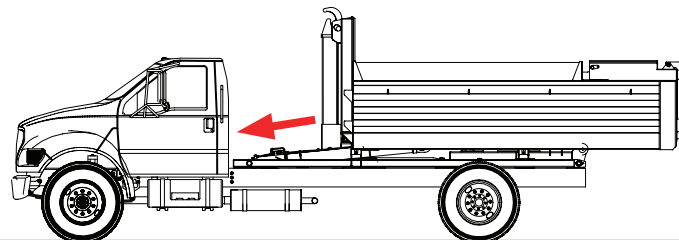
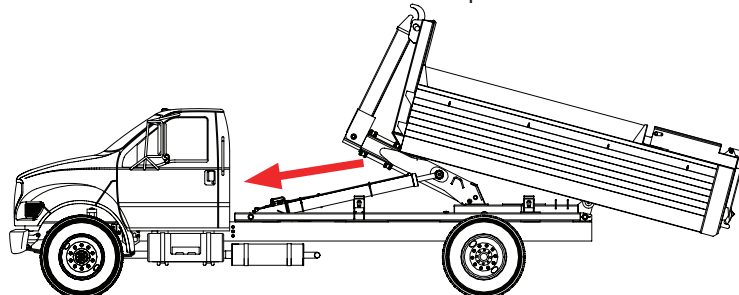

Finally, push the control lever labeled 'Jib' to slide the jib forward until the body latches fully engage. Disengage the PTO.

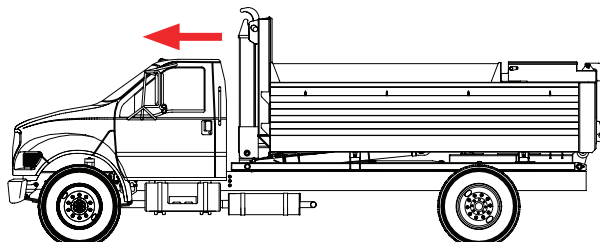

Unloading Operation

Put the truck in neutral and engage the PTO.

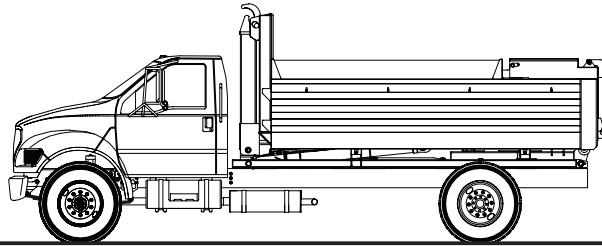

Pull the control lever labeled 'Jib' to slide the jib as far back as it will go, effectively releasing the dump latches. **NOTE:** For info on the Slider 20-S and Slider 26 models, see note on page 5.

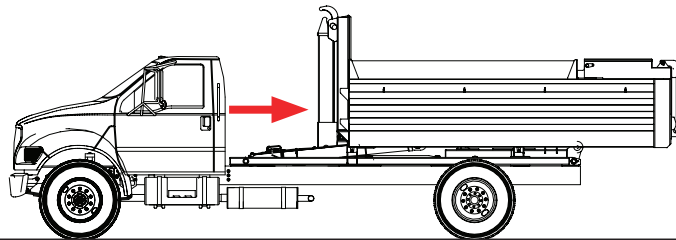

Pull the control lever labeled 'Lift' until the body is on the ground.

WARNING Do not use the hooklift to move personnel.

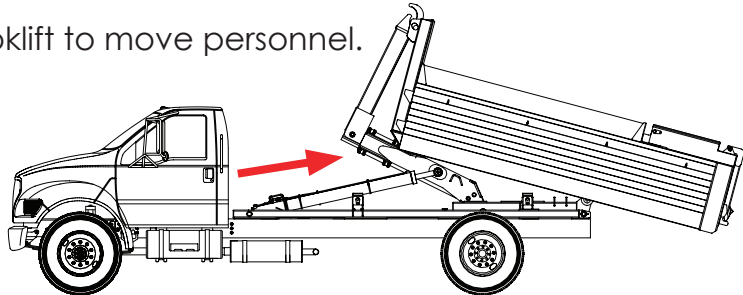

WARNING Do not leave hooklift unattended with suspended load.

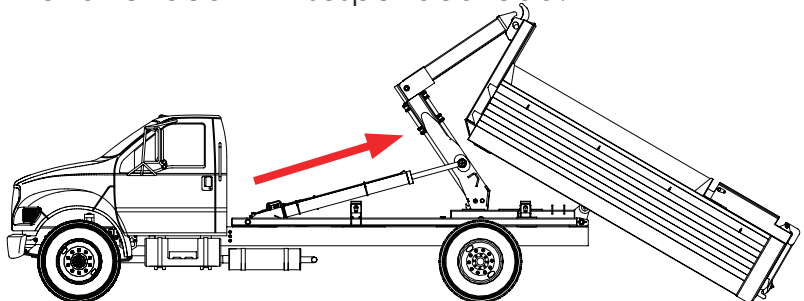

NOTICE If the container will experience a significant restriction to movement during unloading, the foot brake must not be used. Allow the truck to roll out from under the load.

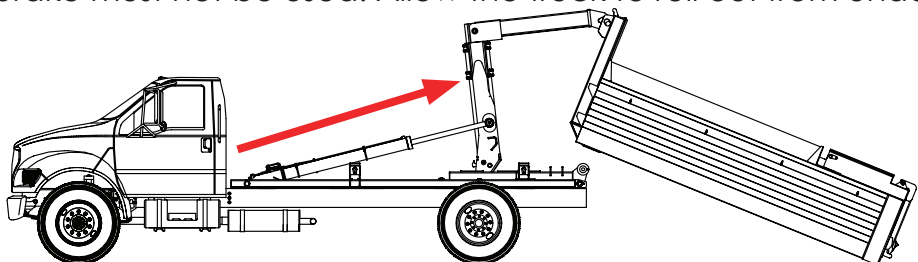

Unloading Operation Continued...

NOTICE

Do not push on fixed objects or bodies without rollers with the hooklift.

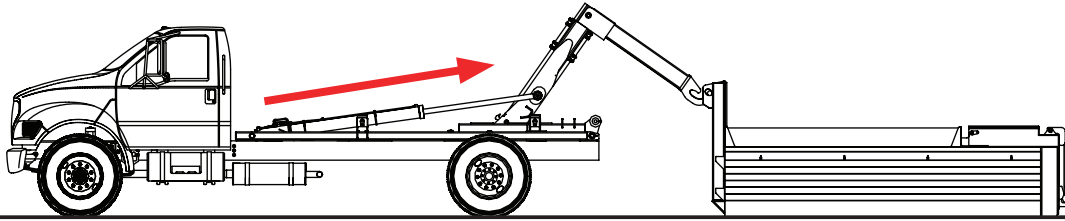

Detach the hooklift from the container by maneuvering the hook using the 'Lift' control lever and pulling the truck forward.

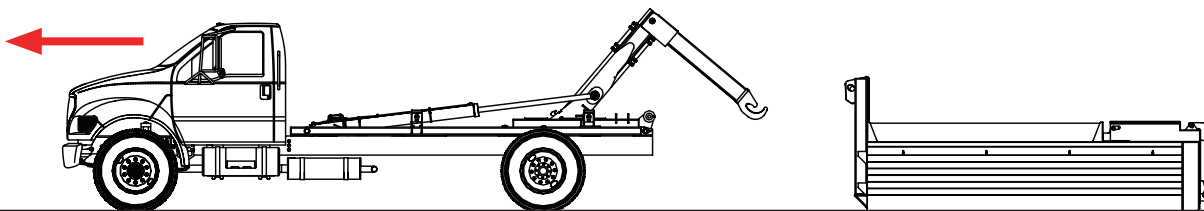

Once fully detached, push the 'Lift' control lever until the lift returns to the loading/unloading position.

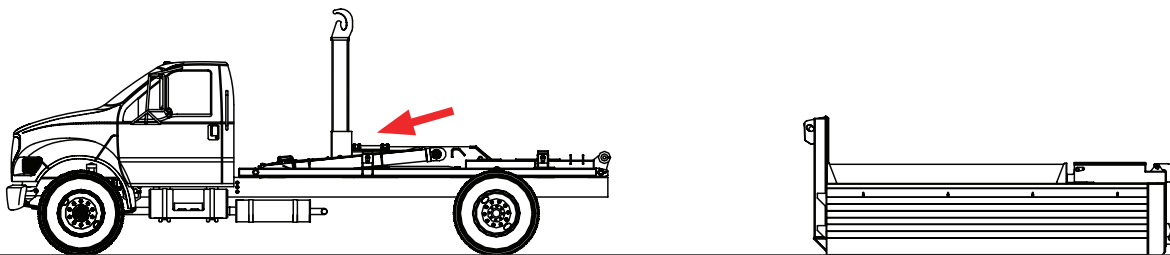
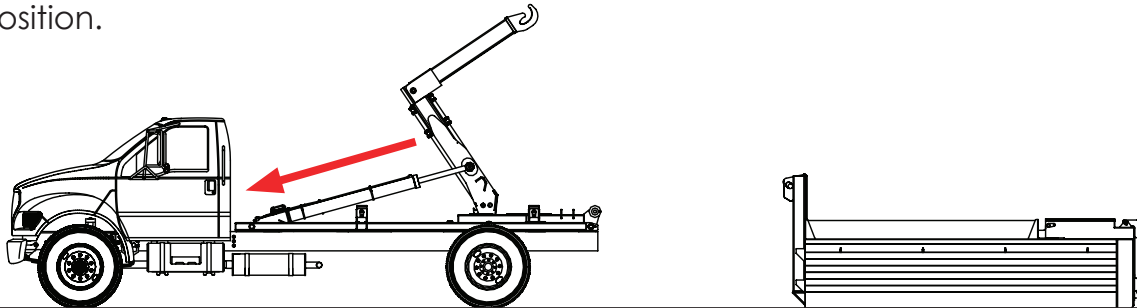

Finally, push the control lever labeled 'Jib' to slide the jib forward into the stowed position. Disengage the PTO.

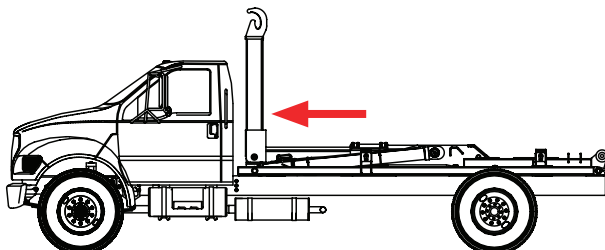

Dumping Operation

Put the truck in neutral and engage the PTO.

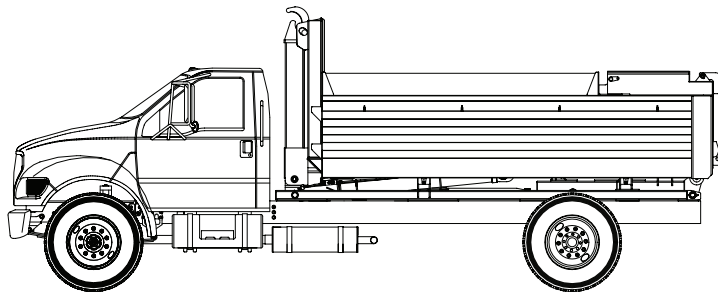

Pull the control lever labeled 'Lift' as desired to dump the load. Be aware and avoid any overhead obstructions during the entire dump procedure.

⚠ WARNING Do not leave hooklift unattended with suspended load.

⚠ WARNING Do not take full rated capacity to full dump angle without some unloading of weight. Full rated dump capacity assumes load will decrease as dump angle increases.

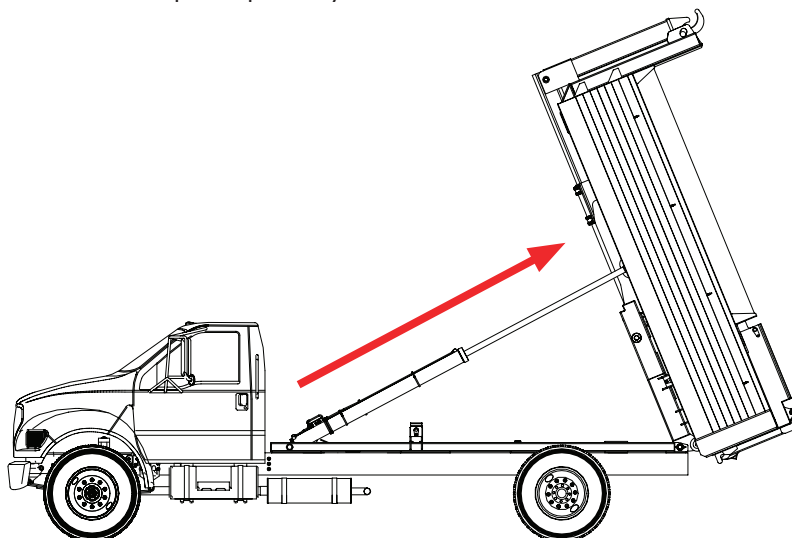

When dumping is complete, push the 'Lift' control lever to return the body to the stowed position. Disengage the PTO.

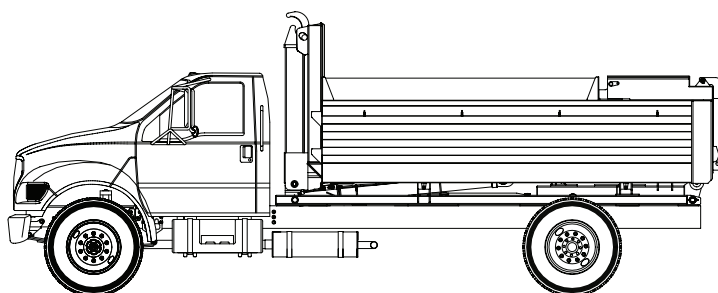

Safety Decals of Note

Safety decals serve to inform the viewer of the hazard type, how to avoid the hazard, and the consequences of not avoiding the hazard.

Decals are considered safety equipment. They must be maintained, as would other safety devices. All safety instruction plates, notices, load charts and any other decal applied to the hooklift or vehicle must be kept legible and in good condition. Replace any decals that are missing, damaged, or illegible.

Detailed below are a number of key safety decals related to this equipment. Use the decal placement drawing in this manual to note the actual location of the safety decals on the equipment.

Hooklift Control Tower



Decal Part Number: 55755

Decal Location: Hooklift Control Tower

Hazard Type: Misuse Hazard

Consequences: Can result in death or serious injury.

Avoidance: Do not attempt to load container unless hook and bail heights match.

Front of Jib



Decal Part Number: 45955

Decal Location: Front of jib

Hazard Type: Misuse Hazard

Consequences: Can result in death or serious injury.

Avoidance: Do not attempt to load container unless hook and bail heights match.

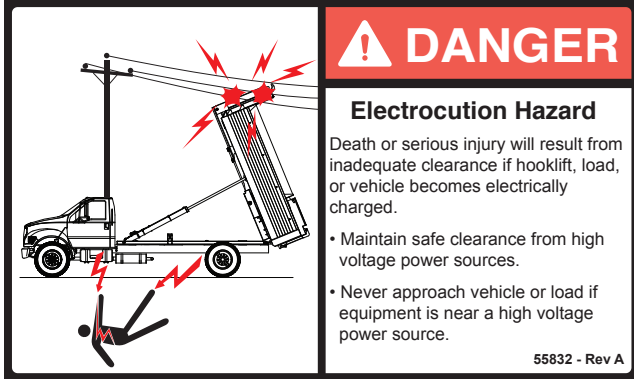

Decal Part Number: 55832

Decal Location: Side of jib

Hazard Type: Electrocutation Hazard

Consequences: Will result in death or serious injury.

Avoidance: Maintain safe clearance from high voltage power sources. Never approach vehicle or load if equipment is near a high voltage power source.

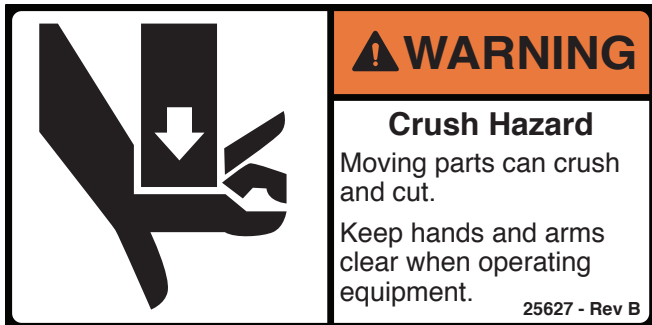

Decal Part Number: 25627

Decal Location: Side of jib

Hazard Type: Crush Hazard

Consequences: Can result in death or serious injury.

Avoidance: Keep hands and arms clear when operating equipment

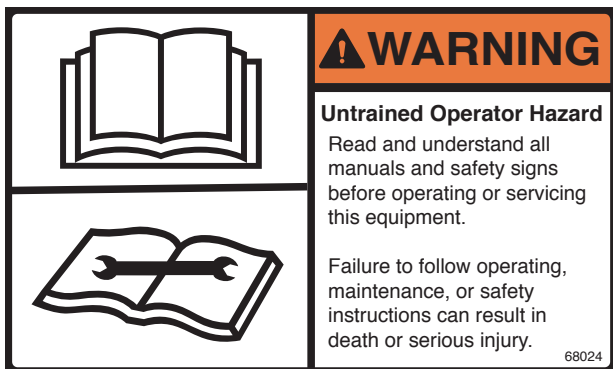

Decal Part Number: 68024

Decal Location: Side of jib

Hazard Type: Untrained Operator Hazard

Consequences: Can result in death or serious injury.

Avoidance: Read and understand all manuals and safety signs before operating or servicing equipment.

This page intentionally left blank.

Chapter 2 - Maintenance

Maintenance is an important part of extending the life of any Stellar® Hooklift. Performing key maintenance items on a scheduled program will prevent unnecessary downtime.

Basic Hooklift Inspection Schedule

At the proper interval, inspect the following items:	Daily	Monthly	Yearly
Hydraulic reservoir oil level	X		
Hydraulic hoses and tubing for evidence of damage such as blistering, crushing, or abrasion	X		
All safety covers for proper installation	X		
Equipment for missing, illegible, or defaced operating decals and safety signs	X		
Structural weldments for bends, cracks, or breaks	X		
All pins and keepers for proper installation	X		
Presence of this owner's manual	X		
All pins, bushings, shafts, and gears for wear, cracks, or distortion to include all pivot points, and bushings	X		
Parking brake operation	X		
Cylinder movement due to leakage		X	
Controls for malfunction or adjustment		X	
Hydraulic systems for proper operating pressure		X	
Cylinders for damaged rods, dented barrels, drift from oil leaking internally, leaks at rod seals or holding valve.		X	
PTO and pump for leaks		X	
Jib assembly for excessive side-to-side play or chattering.		X	
Frame bolt tightness - turn barrel nuts and mounting bolts during the first month of operation on new machines and then quarterly thereafter		X	
Inspect all electrical wires and connections for worn, cut, or deteriorated insulation and bare wire		X	
Lubrication of all moving parts		X	
Inspect manual hook height set pins for wear or damage. Replace if necessary.			X

General Maintenance Guidelines

Before performing any maintenance to the hooklift, consider the following:

- **⚠ WARNING** Only qualified service personnel are to perform maintenance on the hooklift. Never modify or alter any of the equipment, whether mechanical, electrical, or hydraulic, without explicit approval from Stellar Industries.
- Position the hooklift where it will be out of the way of other operations or vehicles in the area.
- Make certain that the hooklift is in the fully stowed position to prevent uncontrolled movement.
- Place all controls in the off position and secure operating features from inadvertent motion.
- When checking hydraulic oil level, make certain that **all system cylinders** are fully retracted.
- Grease zerk locations can be found in the *Installation, Assembly Drawings, Parts Manual*.
- Before any service or repair is performed, disengage the PTO and shut off the engine.
- Before performing any maintenance on electrical components, disconnect the power source.
- Before performing any maintenance on hydraulic components, relieve hydraulic oil pressure from all hydraulic circuits. Move control levers repeatedly through their operating positions to relieve all pressures.
- **⚠ WARNING** Do not disconnect hydraulic hoses while there is still pressure in those components.
- **⚠ WARNING** Do not touch or grab any hoses that could be under pressure.
- Replace parts with Stellar® approved parts only.
- Keep the hooklift clean and free from grease build-up, oil and dirt to prevent slippery conditions.
- Label or tag parts when disassembling.
- Immediately repair or have repaired any components found to be inadequate.

Hydraulic Oil/Filter Maintenance

Stellar Industries recommends the first filter change to occur after the first 250 hours of service. The second, and every subsequent change, should occur after every 1,000 hours of service. By following these guidelines, the hydraulic oil should last up to 6,500 hours.

Note: These recommendations are based on normal working parameters. If operating in less than favorable conditions excessive dust, moisture, etc.), be sure to check the filter gauge often for filter change notice.

PTO and Pump Maintenance

Every six (6) months, remove the hydraulic pump from the PTO and lubricate the splines using Chelsea Lubricant #379831 or Stellar PN 42042 (packet) or PN 20885 (lube). Failure to lubricate shaft splines will cause damage to the PTO and Hydraulic pump.

Grease Zerk Locations

The pivot points on the Stellar® Hooklift will need to be greased monthly to prevent the bushings from wearing out. Grease more frequently if the hoist is used 7 days a week. Use an Extreme Pressure Grease (EP2). It should be a Lithium Complex type NLGI 2 grease.

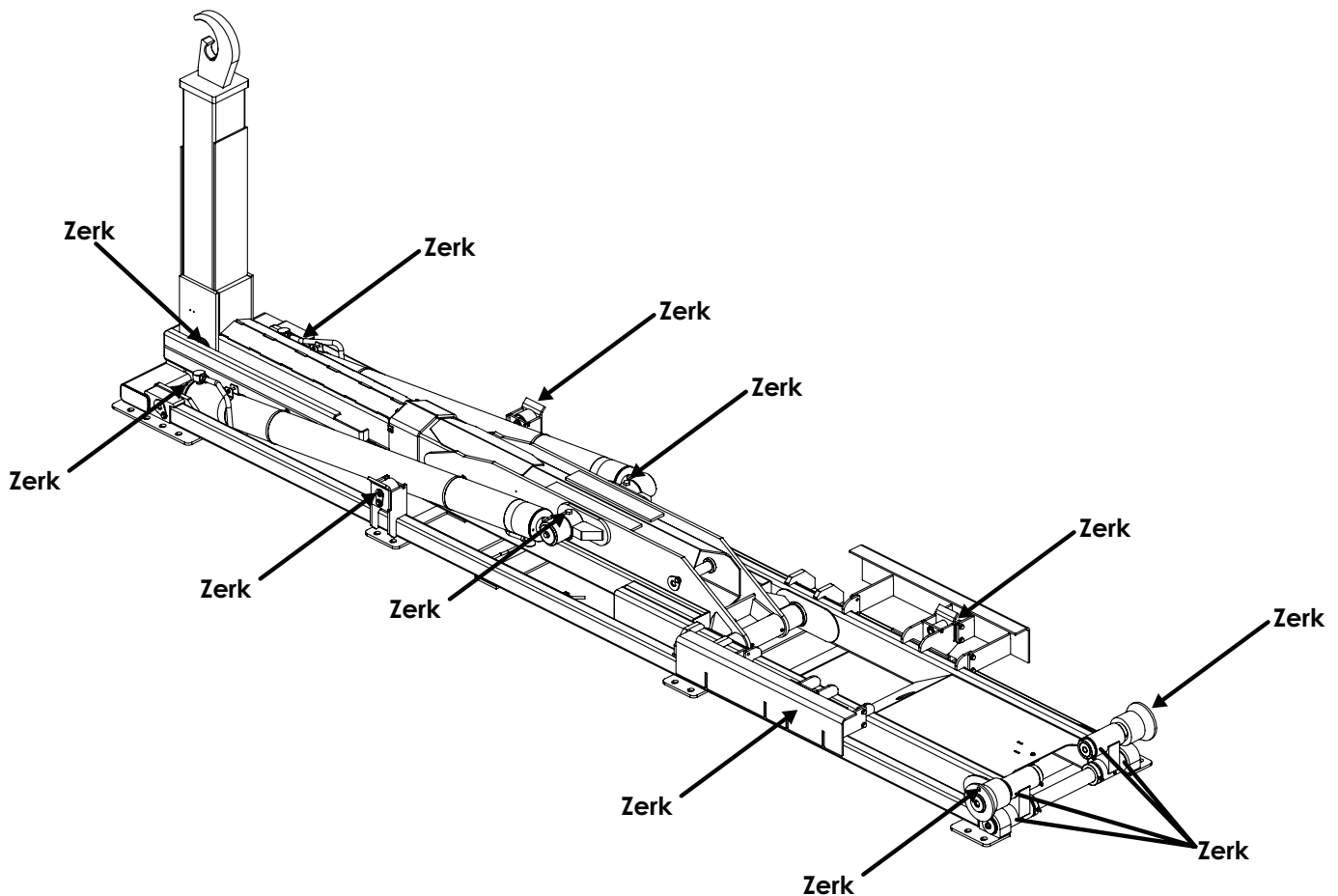

Choice Lubricants for DX Bearings

Greases Recommended

Type of Grease	Description
Premium Quality	Stabilized, Anti-Oxidant Lithium Base, Lithium Base with 3% Molybdenum Disulfide, High Drop Point
Multi-Purpose	Calcium Based, for General Automotive and Industrial Use, Calcium Grease, Water Stabilized, High Drop Point
Anti-Friction Bearing	Calcium Based with EP Additives, Lithium Based, Sodium Based
Extreme Pressure (EP)	Lithium Based with EP Additives, Calcium Based with EP Additives
High Temperature	Modified Sodium Based, High Drop Point
Transmission	Semi-Fluid, Calcium Based
Molybdenum Filled	Lithium Based with 2% Molybdenum Disulfide
Graphite Filled	Sodium Based with 2% Graphite
Block Grease	Sodium Based Solid Grease
White Grease	Aluminum Complex Based with Anti-Oxidant & Rust, Inhibitors & Zinc Oxide Additives
Silicone	Lithium Based with Silicone Oil Lubricant
Aerosol Lubricant	Silicone-based Lubricant

Greases Not Recommended

Type of Grease	Description
Cup Grease	Light Service Calcium or Sodium Based Grease
Graphite Filled	Greases with More than 10% Graphite
Molybdenum Filled	Greases with More than 10% Molybdenum Disulfide
Fluorocarbon	Low Molecular Weight Chlorofluoroethylene Polymer with Inert Thickeners
White Grease	Calcium Based, Zinc Oxide Filled

Chapter 3 - Troubleshooting

This chapter will list a number of potential problems that may occur while operating the Hooklift. Most problems are easily solved using the solutions portion of this chapter. If problems persist, please contact **Customer Service at Stellar Industries: 1-800-321-3741**.

Serial Tag Location

The serial tag should be located on the right side (passenger side) of the base assembly:

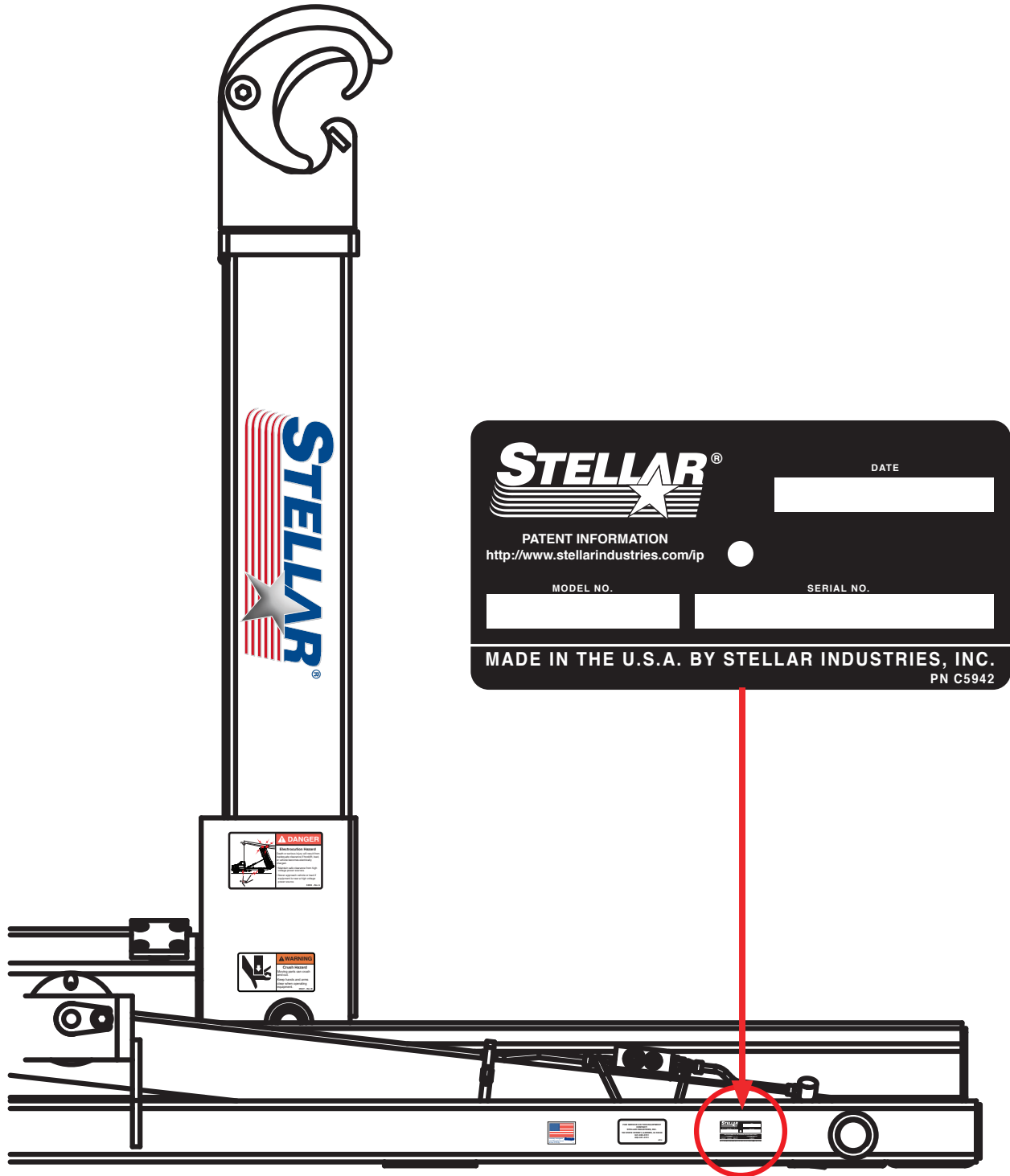

General Troubleshooting

Problem: Hooklift will not operate or operates slow.

Solutions:

- Make sure the PTO is engaged.
- Make sure the control lever/cable assembly or air actuator are shifting the spool valves on the valve section
- Make sure that the hydraulic pump is operating at its rated flow or GPMs under load. Check the flow by using a flow meter to determine the GPMs. To find the proper flow the equipment is to operate at, see your specific hooklift model's *Installation, Assembly Drawings, Parts Manual*.
- Make sure the relief pressure is properly set per the specifications page of the hooklift owners manual.
- Make sure the spool valves on the valve bank are adjusted and operating smoothly.

Problem: Hydraulic system gets extremely hot.

Solutions:

- Make sure the hydraulic filter has been changed per the maintenance page of the Hooklift Owner's Manual.
- Make sure the filter strainer of the hydraulic reservoir is not plugged.
- Make sure that the hydraulic pump is operating at its rated flow or GPMs.
- Make sure the relief pressure is set properly. See the Table in the installation chapter of your specific hooklift model's *Installation, Assembly Drawings, Parts Manual*.

Problem: Hooklift will not lift or pickup a loaded container.

Solutions:

- Make sure the container contents are evenly distributed.
- Make sure the container and its load does not exceed the rated capacity.
- Make sure the relief pressure is properly set per the Table on in the installation chapter of your specific hooklift model's *Installation, Assembly Drawings, Parts Manual*.
- Make sure the hydraulic pump is operating at its rated flow or GPMs. See the specifications page in your specific hooklift model's *Installation, Assembly Drawings, Parts Manual*.
- Make sure that the container is not fixed to the ground or frozen down.

Problem: Cylinders drift upward or downward while hydraulics are disengaged.

Solutions:

- Make sure valve spools are shifting to the neutral position.
- Possible contamination keeping the holding valve open.
- Possible internal piston seals rolled or damaged.

Problem: Hooklift binds at pivot points.

Solutions:

- Make sure the pivot points are lubricated.
- Make sure pivot pins are not seized to the bushing.
- Make sure the weldments or pins are not misaligned or bent.

Contact Stellar® Customer Service: 1-800-321-3741

Dump Latch System Procedure

In the event that the hooklift is operated out of sequence, the bolts holding the dump tabs will break:

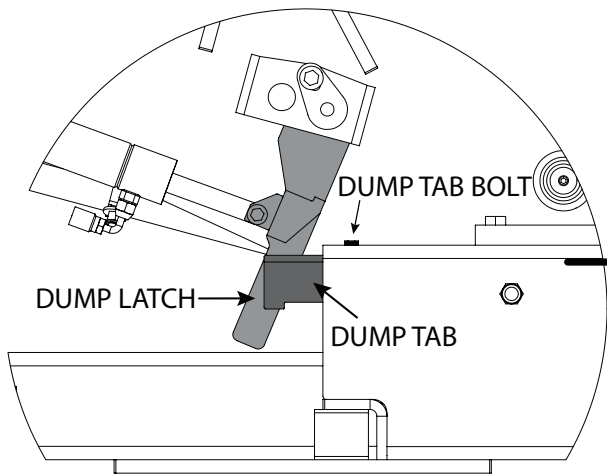

Image shows dump latch out of sequence.

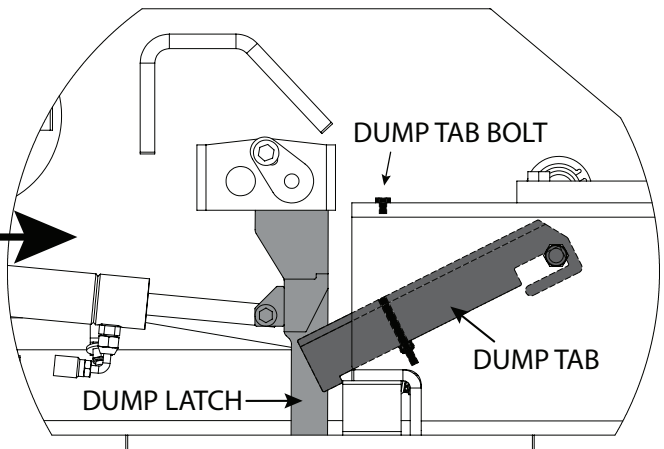
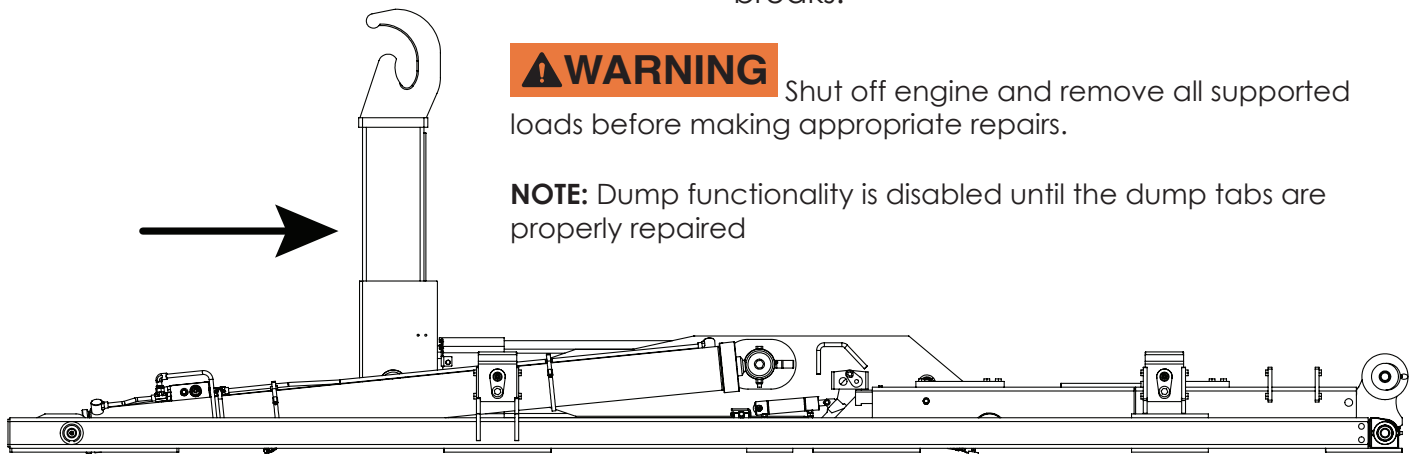
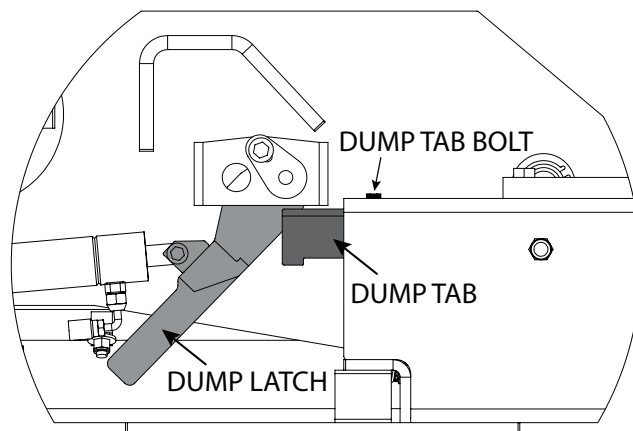

Image shows dump tab bolt broken. As the dump latch pushes down on the dump tab, the bolt holding the tab in place breaks.



To repair the dump latch system, leave the lift cylinders fully retracted in the stowed position as well as fully retracting the Jib and Lock cylinder so that the dump latch is out of the way.



Finally, install new dump tab bolts on both sides of the hooklift as shown above.

NOTE: Dump tab bolts are 0.25-20X2.75 HHGR5 (both sides).



Subject to Change without Notification.
© 2022 Stellar Industries, Inc.