

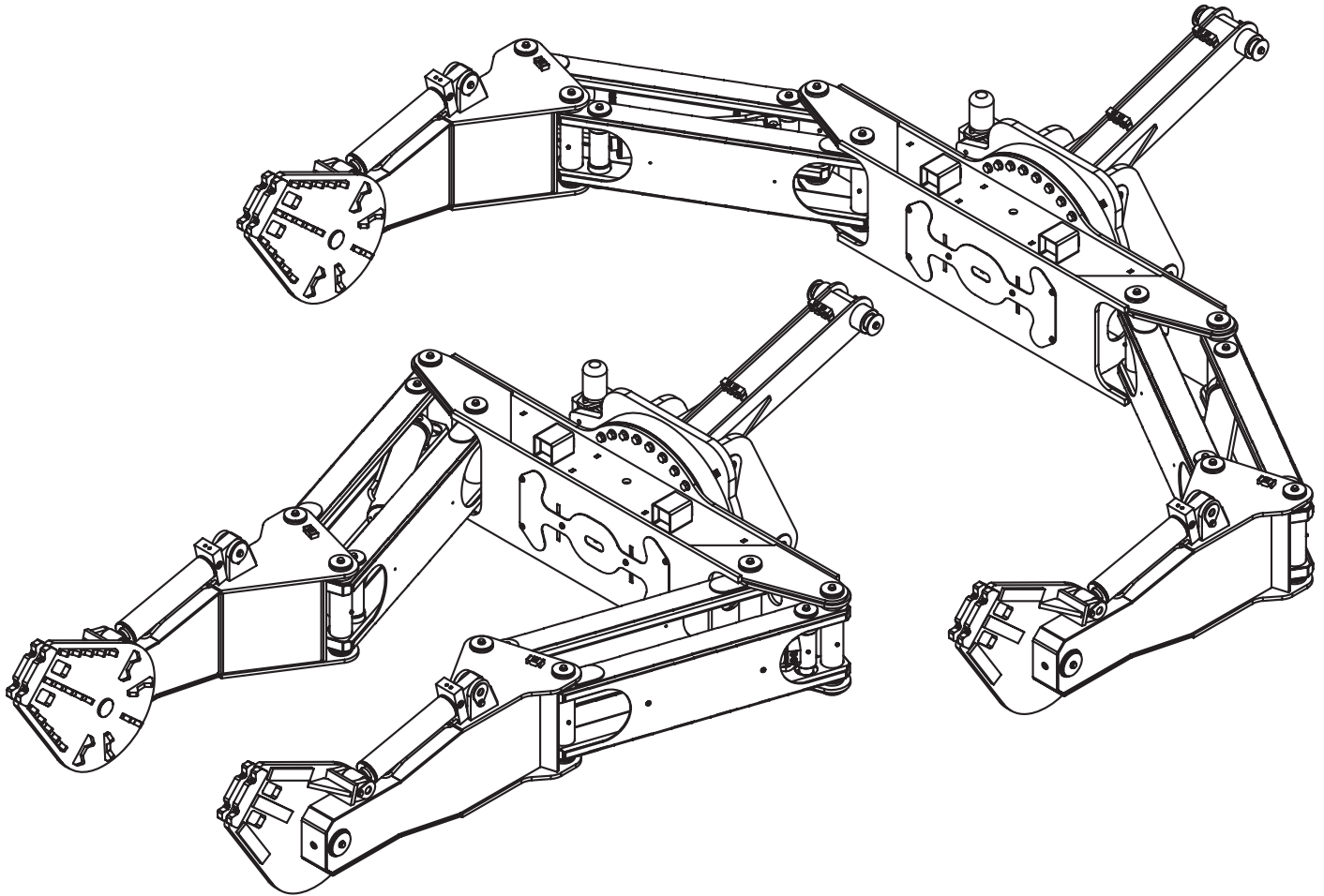

# TireMan 12154

## Owner's Manual

Installation • Assembly Drawings • Parts



**Notice: A copy of this manual must remain with the equipment at all times.  
For a printable download copy, please visit: [www.stellarindustries.com](http://www.stellarindustries.com)**

**Stellar Industries, Inc.**

**190 State Street**

**PO Box 169**

**Garner, IA 50438**

**800-321-3741**

**Fax: 641-923-2811**

**[www.stellarindustries.com](http://www.stellarindustries.com)**

## P65 Warning / Cold Weather Notice

### **WARNING**

Operating, maintaining, and servicing a Stellar product may expose you to chemicals including, but not limited to, engine exhaust, carbon monoxide, phthalates, and lead. These chemicals are known to the State of California to cause cancer and birth defects (or other reproductive harm). To keep your exposure to a minimum, be sure to avoid breathing exhaust and service your Stellar product in a well-ventilated area while wearing gloves or washing your hands frequently. For more information, go to [www.P65Warnings.ca.gov/passenger-vehicle](http://www.P65Warnings.ca.gov/passenger-vehicle).

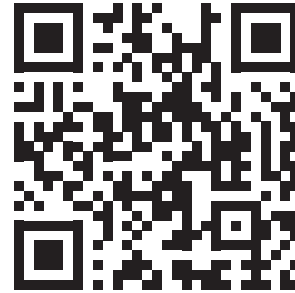

[www.p65/warning.ca.gov](http://www.p65/warning.ca.gov)

### **NOTICE**

#### **Cold Weather Performance**

**Although clear data on cold weather performance from every steel manufacturer is not available for all types and thicknesses of steel, Stellar Industries is confident that the weldments on our products will operate to 100% of their intended purpose to temperatures down to -40° F / C.**

**It is recommended if Stellar manufactured equipment needs to be used in temperatures below -40° F / C, the operator should pull the unit into a climate-controlled area and allow the weldments to warm up to and then maintain a temperature above this level.**

# Table Of Contents

---

Introduction .....	iv
<b>Chapter 1 - Specifications .....</b>	<b>1</b>
Specifications .....	2
TM12154 Dimensional Layout .....	3
TM12154 Dimensional Layout (Continued) .....	4
<b>Chapter 2 - Specifications .....</b>	<b>5</b>
General Installation .....	6
Installer Notice .....	6
Torque Data Chart .....	7
Hydraulic Installation .....	8
Hydraulic Pressure Settings .....	9
Face Seal/O-Ring Size Chart .....	9
Hydraulic Kit w/Rotating Pads - PN 78017 .....	10
Hydraulic Kit w/Rotating Pads - PN 78017 Parts List .....	11
Hydraulic Kit w/Continuous Rotating Pads - PN 105060 .....	12
Hydraulic Kit w/Continuous Rotating Pads - Parts List .....	13
<b>Chapter 3 - Assembly Drawings .....</b>	<b>15</b>
TM12154 CRP Assembly - PN 128725 .....	16
TM12154 CRP Assembly - PN 128725 Parts List .....	17
TM12154 CRP Assembly - PN 128725 Parts List .....	18
TM12154 RP Assembly - PN 128726 .....	20
TM12154 RP Assembly - PN 128726 Parts List .....	21
TM12154 RP Assembly - PN 128726 Parts List .....	22
Decal Placement - PN 44525 .....	24
Decal Placement - PN 44525 Parts List .....	25

# Introduction

A copy of this manual is provided with every tire manipulator and can be found in the hard plastic manual case that is installed on the chassis. A copy of this manual shall remain with the tire manipulator at all times.

Throughout the manual, three signal words will be used to bring attention to important items:

## **NOTICE**

A NOTICE signal word indicates a practice not related to physical injury.

## **⚠ WARNING**

A WARNING signal word indicates a hazardous situation which, if not avoided, could result in death or serious injury.

## **⚠ DANGER**

A DANGER signal word indicates a hazardous situation which, if not avoided, will result in death or serious injury.

Information contained within this manual does not cover operation, maintenance, or troubleshooting. Please refer to the Large OTR Crane Manual for details on these items.

This manual is not binding. Stellar Industries, Inc. reserves the right to change, at any time, any or all of the items, components, and parts deemed necessary for product improvement or commercial/production purposes. This right is kept with no requirement or obligation for immediate mandatory updating of this manual.

In closing:

If more information is required or technical assistance is needed, or if you feel that any part of this manual is unclear or incorrect, please contact the Stellar Customer Service Department by phone at 800-321-3741 or email at [service@stellarindustries.com](mailto:service@stellarindustries.com).

**For Technical Questions, Information, Parts, or Warranty, Call Toll-Free at  
800-321-3741**

Hours: Monday - Friday, 8:00 a.m. - 5:00 p.m. CST

Or email at the following addresses:

**Technical Questions, and Information**

[service@stellarindustries.com](mailto:service@stellarindustries.com)

**Order Parts**

[parts@stellarindustries.com](mailto:parts@stellarindustries.com)

**Warranty Information**

[warranty@stellarindustries.com](mailto:warranty@stellarindustries.com)

# Chapter 1 - Specifications

## CHAPTER CONTENTS

Specifications .....	2
Dimensional Layout .....	3

# Specifications

MAXIMUM RATED LOAD  
**12000 LBS**

(5443 KG)

EXCEEDING MAXIMUM RATED LOAD WILL  
 DAMAGE EQUIPMENT AND VOID WARRANTY

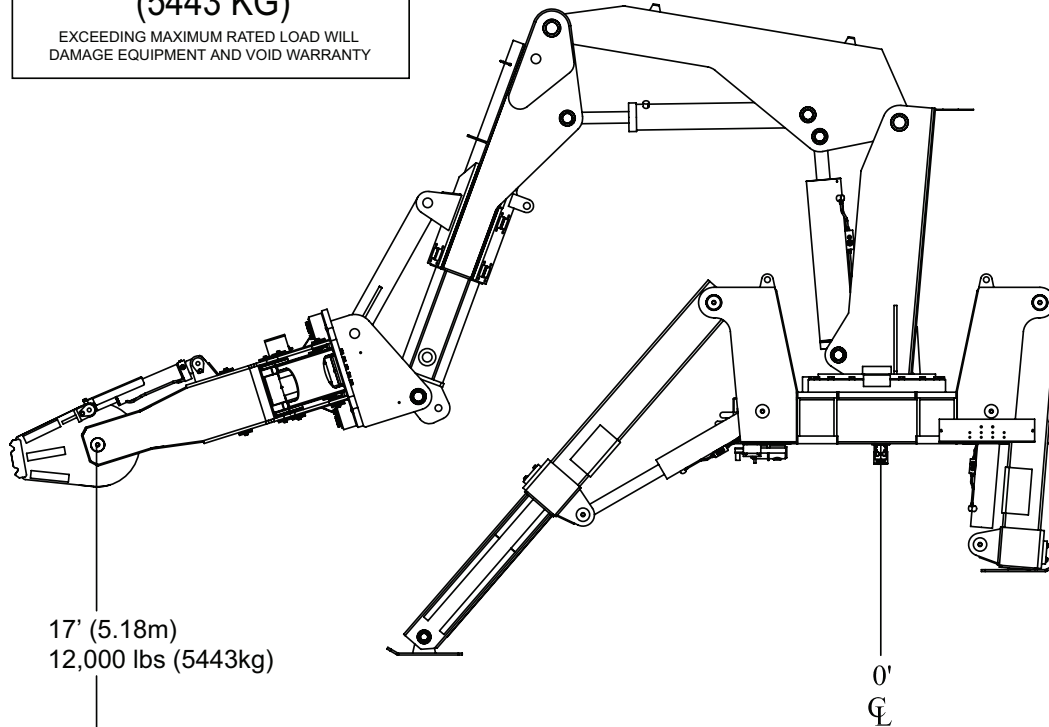

<b>Capacity:</b>	12,000 lbs @ 17 ft (5,443 kg @ 5.18 m)
<b>Clamping Span:</b>	90° Rotating Pads - 36" to 153" (90 cm to 388 cm) Cont. Rotating Pads - 36.3" to 153.5" (92 cm to 388 cm)
<b>Clamp Cylinders:</b>	4" (10.16 cm) bore with pilot operated check valves
<b>Tilt Cylinder:</b>	Provided by crane extension boom
<b>Body Rotation:</b>	315° power
<b>Rotation System:</b>	Worm gear
<b>Clamping Pad Rotation:</b>	90° Rotating Pads - 89° power Cont. Rotating Pads - Continuous 360° power
<b>TireMan Tilt:</b>	+82° to -22°
<b>Hydraulic Controls:</b>	Incorporated with the crane controls
<b>Approximate Shipping Weight:</b>	5,150 lbs (2,336 kg) RP Version 5,800 lbs (2,631 kg) CRP Version

# TM12154 Dimensional Layout

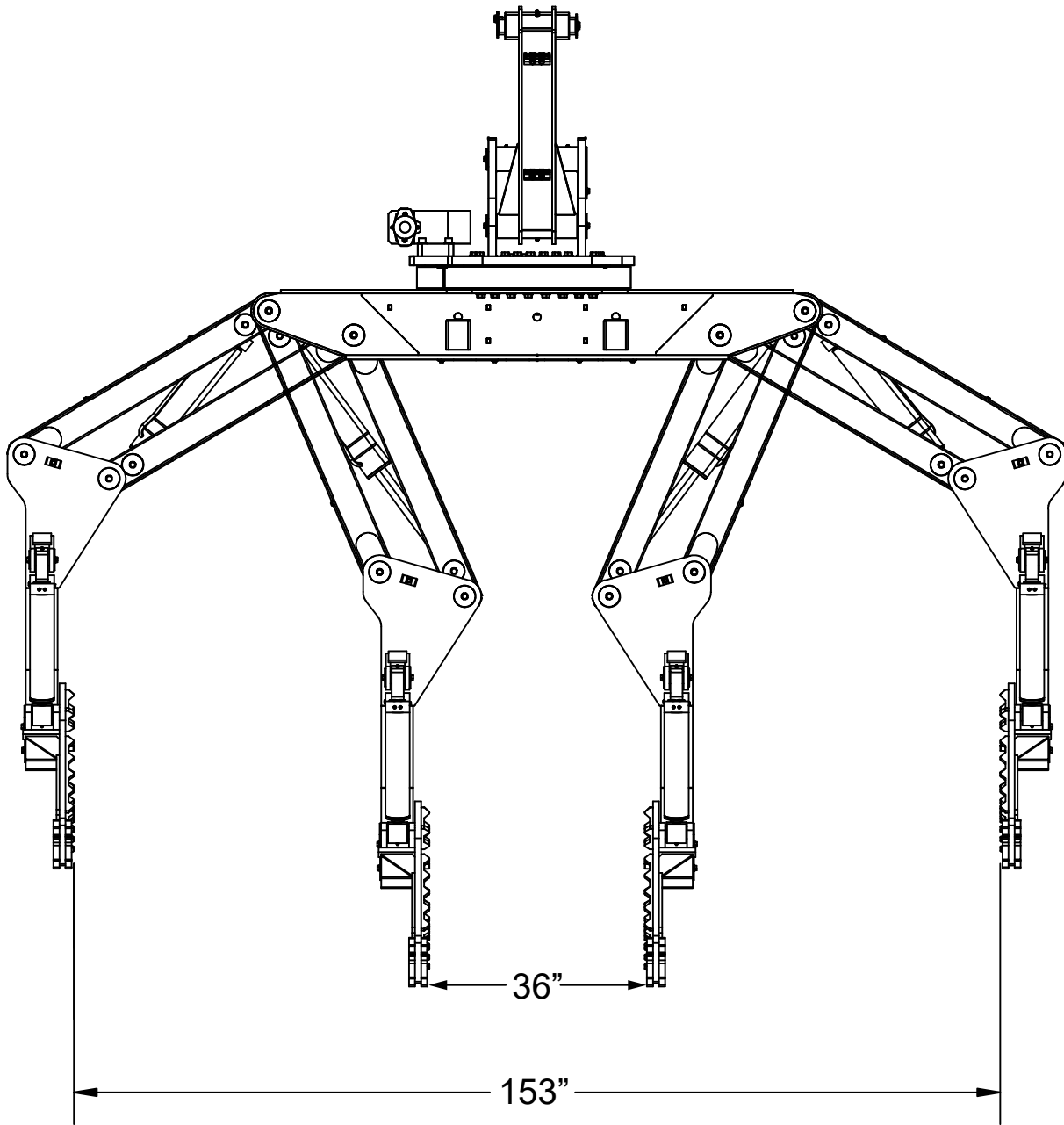

# TM12154 Dimensional Layout (Continued)

## TIREMAN TILT

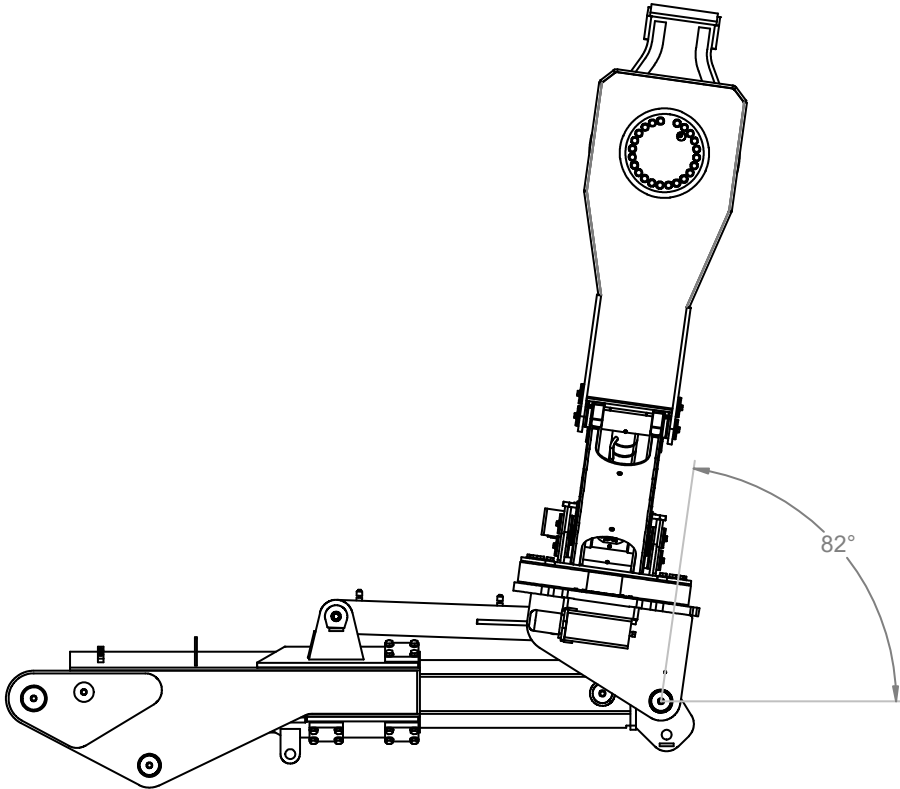
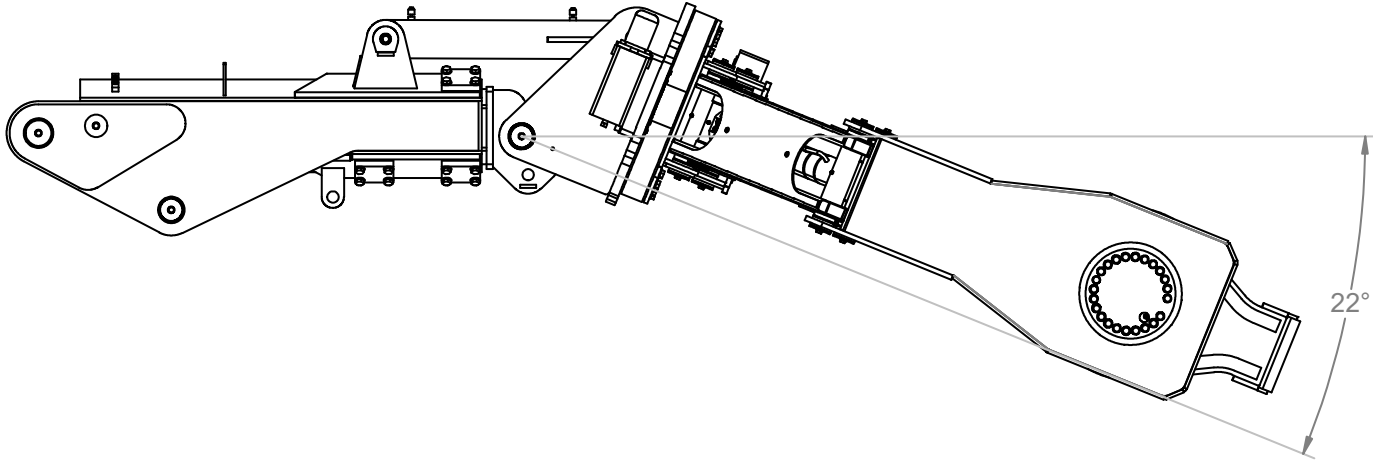



# Chapter 2 - Specifications

## CHAPTER CONTENTS

General Installation .....	6
Installer Notice .....	6
Torque Data Chart .....	7
Hydraulic Installation .....	8
Hydraulic Pressure Settings .....	9
Face Seal / O-Ring Size Chart .....	9
Hydraulic Kit - With Rotating Pads (78017).....	10
Hydraulic Kit - With continuous Rotating Pads (105060) .....	12

## General Installation

This chapter is designed to serve as a general guide for the installation of a Stellar TM12154 on a Stellar Service Crane. Each installation is considered unique so certain portions of this chapter may or may not apply to your direct application. If a question should arise during the installation process, please contact Stellar Customer Service at (800) 321 3741.

This crane is designed for use with a Stellar Service Crane installed on a vehicle that meets the minimum chassis requirements of the crane. It is the installer's responsibility to assure that the unit is mounted on a platform that will support the maximum crane rating of this crane.

**⚠ WARNING** Do not install this crane/manipulator on a body not capable of handling the loads imposed on it. Failure to do so may result in serious injury or death.

## Installer Notice

According to Federal Law (49 cfr part 571), each final-stage manufacturer shall complete the vehicle in such a manner that it conforms to the standards in effect on the date of manufacture of the incomplete vehicle, the date of final completion, or a date between those two dates. This requirement shall, however, be superseded by any conflicting provisions of a standard that applies by its terms to vehicles manufactured in two or more stages.

Therefore, the installer of Stellar® Cranes and Bodies is considered one of the manufacturers of the vehicle. As such a manufacturer, the installer is responsible for compliance with all applicable federal and state regulations. They are required to certify that the vehicle is in compliance with the Federal Motor Vehicle Safety Standards and other regulations issued under the National Traffic and Motor Vehicle Safety Act.

Please reference the Code of Federal Regulations, title 49 - Transportation, Volume 5 (400-999), for further information, or visit <http://www.gpoaccess.gov/nara/index.html> for the full text of Code of Federal Regulations.

## Torque Data Chart

When using the torque data in the chart, the following rules should be observed:

- Bolt manufacturer's particular specifications should be consulted when provided.
- Flat washers of equal strength must be used.
- All torque measurements are given in foot-pounds. To convert to inch-pounds, multiply by 12.
- Torque values specified are for bolts with residual oils or no special lubricants applied.
- Torque values for socket-head capscrews are the same as for Grade 8 capscrews.

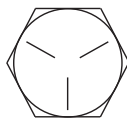
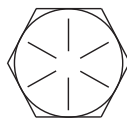
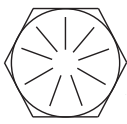
		GRADE 5		GRADE 8		GRADE 9
						
Size (DIA-TPI)	Bolt DIA (Inches)	Plain (Ft-Lb)	Plated (Ft-Lb)	Plain (Ft-Lb)	Plated (Ft-Lb)	Plated (Ft-Lb)
5/16-18	0.3125	17	13	25	18	22
3/8-16	0.3750	31	23	44	33	39
7/16-14	0.4375	49	37	70	52	63
1/2-13	0.5000	75	57	105	80	96
9/16-12	0.5625	110	82	155	115	139
5/8-11	0.6250	150	115	220	160	192
3/4-10	0.7500	265	200	375	280	340
7/8-9	0.8750	395	295	605	455	549
1-8	1.000	590	445	910	680	823
1 1/8-7	1.1250	795	595	1290	965	1167
1 1/4-7	1.2500	1120	840	1815	1360	1646
1 3/8-6	1.3750	1470	1100	2380	1780	2158
1 1/2-6	1.500	1950	1460	3160	2370	2865

- **NOTICE** Do not use these values if a different torque value or tightening procedure is given for a specific application. Torque values listed are for general use only. Check tightness of fasteners periodically.
- Shear bolts are designed to fail under predetermined loads. Always replace shear bolts with identical grade.
- Fasteners should be replaced with the same or higher grade. If higher grade fasteners are used, these should only be tightened to the strength of the original.
- Tighten plastic insert or crimped steel-type lock nuts to approximately 110 percent of the dry torque values shown in the chart below, applied to the nut, not to the bolt head. Tighten toothed or serrated-type lock nuts to the full torque value. *Note: "Lubricated" means coated with a lubricant such as engine oil, or fasteners with phosphate and oil coatings. "Dry" means plain or zinc plated without lubrication. Tighten lubricated bolts to approximately 80% of dry bolts.*

# Hydraulic Installation

Never modify or alter any of the equipment, whether mechanical, electrical, or hydraulic, without Stellar Industries' approval.

**⚠ WARNING** Do not touch or grab any hoses that could be under pressure. Release system pressure before attempting to make adjustments or repairs.

Do not attempt service or repair when PTO is engaged.

Disassemble and assemble hydraulic components on a clean surface.

Clean all metal parts in a nonflammable cleaning fluid. Then lubricate all components to aid in assembly.

**⚠ WARNING** Hydraulic fluid expands when heated. This raises the pressure in an unventilated tank. Release the tank pressure before removing the cap completely. Failure to do so may cause the oil to shoot out of the tank very rapidly and cause severe burns.

**⚠ WARNING** Do not rely on the hydraulic fluid to support the boom or crane. If hydraulic fluid escapes, the boom or crane can fall immediately. Make sure the ground or blocking is supporting the boom before performing any maintenance or repair.

**NOTICE** Contaminants in a hydraulic system affect operation and will result in serious damage to the system components. Dirty hydraulic systems are a major cause of component failures.

If evidence of foreign particles is found in the hydraulic system, flush the system.

When installing metal hydraulic tubes, tighten all fittings finger tight. Then, in order, tighten the fittings at the rigid end, the adjustable end, and the mounting brackets. After tubes are mounted, install the hoses. Connect both ends of the hose with all fittings finger tight. Position the hose so it does not rub the machine or another hose and has a minimum of bending and twisting. Tighten fittings in both couplings.

Due to manufacturing methods, there is a natural curvature to a hydraulic hose. The hose should be installed so any bend is with this curvature.

## Hydraulic Pressure Settings

Main Relief 4600 psi			
		Pressure (psi)	
Function	Flow (gpm)	Extend	Retract
Inner	10.6	4400	2200
Outer	10.6	4400	2200
Extension	10.6	4400	4400
Rotation	10.6	2200	2200
TM Rot	6.6	2200	2200
TM Pad Rot	6.6	2500	2500
TM Clamp	6.6	4200	4200

## Face Seal/O-Ring Size Chart

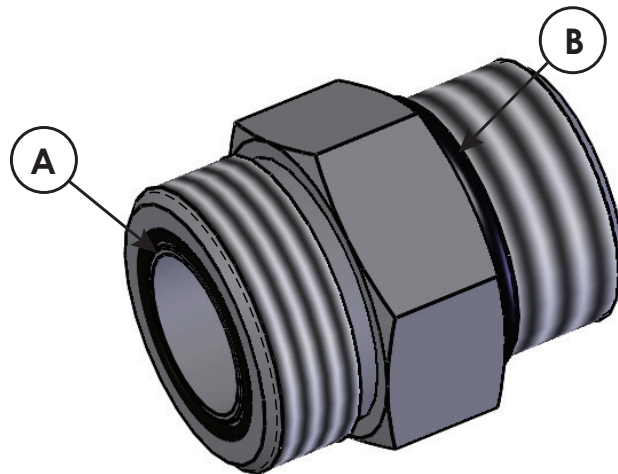

Hose Size	Fitting Size	Face Seal (A) Stellar® PN	O-ring Boss (B) Stellar® PN
1/4"	#4	C2027	D1245
3/8"	#6	C2028	D1246
1/2"	#8	C2029	D1247
5/8"	#10	32223	D1248
3/4"	#12	D1244	D1249
1"	#16		D1250

# Hydraulic Kit w/Rotating Pads - PN 78017

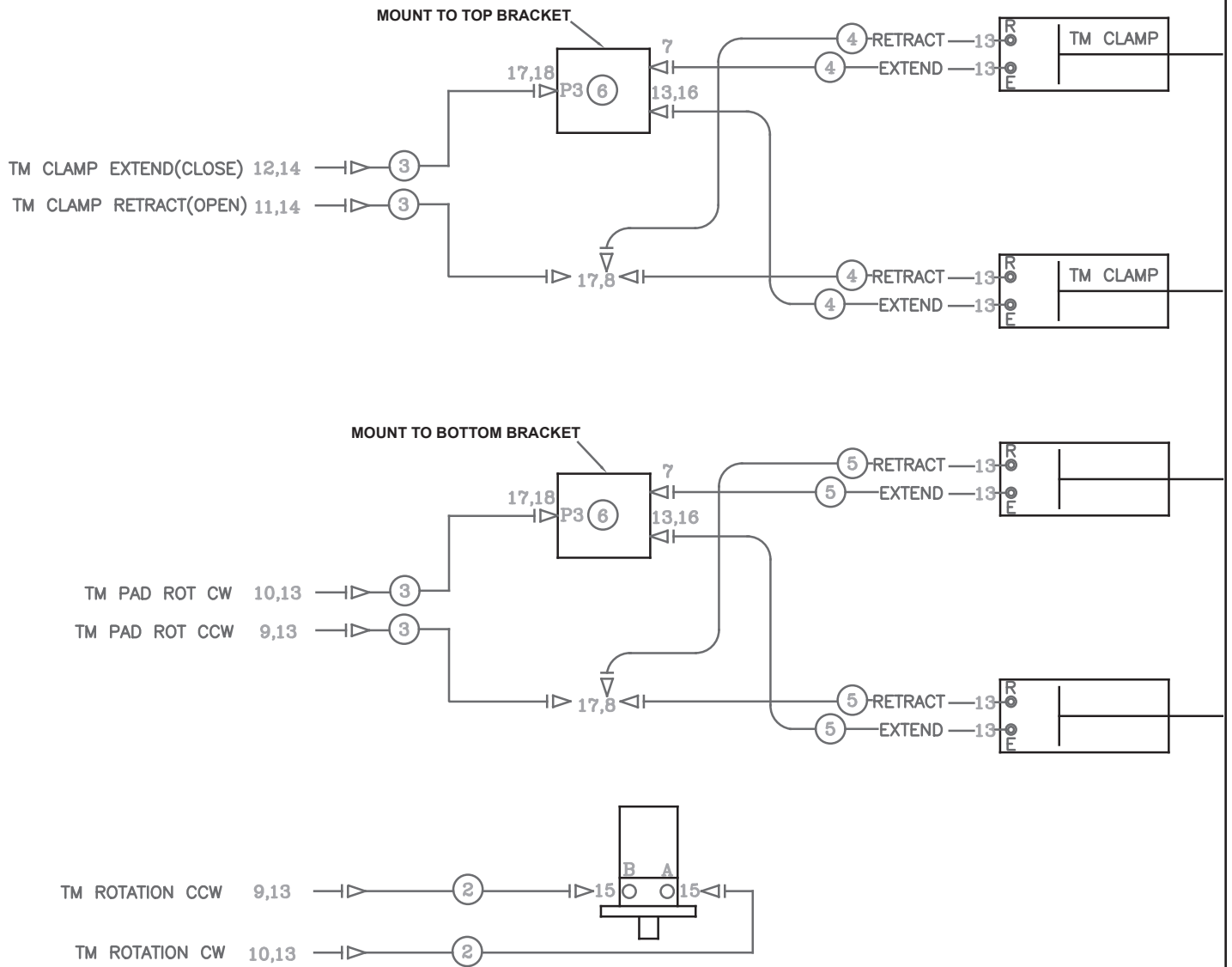

**NOTE:**  
USE SPIRAL HOSE WRAP (53479) OVER HOSES THROUGH BODY ROTATION AREA

# Hydraulic Kit w/Rotating Pads - PN 78017 Parts List

PN 78017			
ITEM	PART	DESCRIPTION	QTY
1	78018	HOSE KIT, TM12154 V3 (INCL:2-5	1
2	71051	HOSE-HYD 0.38 X 76	2REF
3	71052	HOSE-HYD 0.38 X 81	4REF
4	71050	HOSE-HYD 0.38 X 60	4REF
5	85508	HOSE-HYD 0.38 X 124	4REF
6	35111	VALVE COMB DIV FD50-44-6T-N-44	2
7	C0338	FTG 6-6 MFS-MAORB 90	2
8	D0107	FTG 6-6-6 MFS-MFS-FFSS BRANCH TEE	2
9	13554	QUICK CPLR FFH04-38-SAE-F	2
10	13555	QUICK CPLR FFH04-38-SAE-M	2
11	13556	QUICK CPLR FFN06-12SAE-F	1
12	13557	QUICK CPLR FFN06-12SAE-M	1
13	0279	FTG 6-6 MFS-MORB STRAIGHT	14
14	C1854	FTG 6-8 MFS-MORB STRAIGHT	2
15	D1302	FTG 6-10 MFS-MAORB 90	2
16	C2248	FTG 6-6 MFS-FFSS MORB STRAIGHT	2
17	12171	FTG 6-6 MFS-MFS SWIVEL STRAIGHT	4
18	33743	FTG 6-6 FFSS-MORB STRAIGHT	2
19	53479	LOOM 1.00 SPIRAL WRAP POLYETHYLENE	4

# Hydraulic Kit w/Continuous Rotating Pads - PN 105060

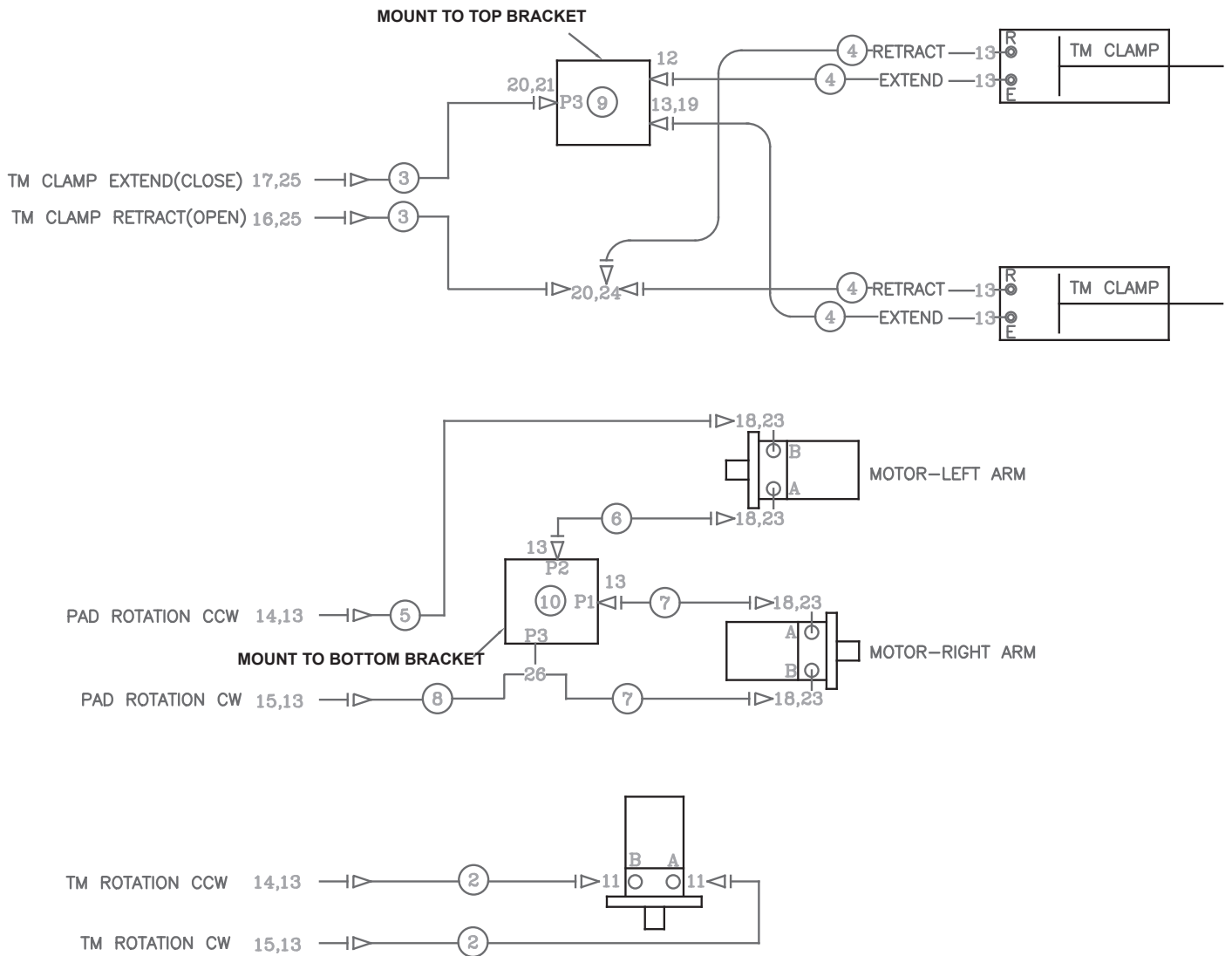

**NOTE:**

USE SPIRAL HOSE WRAP (53479) OVER HOSES THROUGH BODY ROTATION AREA



# Hydraulic Kit w/Continuous Rotating Pads - Parts List

## PN 105060

ITEM	PART	DESCRIPTION	QTY
1	105061	HOSE KIT TM12154 V4 CONT ROT PADS	1
2	71051	HOSE-HYD 0.38 X 76	2REF
3	71052	HOSE-HYD 0.38 X 81	2REF
4	71050	HOSE-HYD 0.38 X 60	4REF
5	85508	HOSE-HYD 0.38 X 124	1REF
6	105064	HOSE-HYD 0.38 X 95	1REF
7	105348	HOSE-HYD 0.38 X 153	2REF
8	105347	HOSE-HYD 0.38 X 153	1REF
9	35111	VALVE COMB DIV FD50-44-6T-N-44	1
10	105063	VALVE SOLND 2 POS 3 WAY SV10-34-6T-N-12DR	1
11	D1302	FTG 6-10 MFS-MAORB 90	2
12	C0338	FTG 6-6 MFS-MAORB 90	1
13	0279	FTG 6-6 MFS-MORB STRAIGHT	11
14	13554	QUICK CPLR FFH04-38-SAE-F	2
15	13555	QUICK CPLR FFH04-38-SAE-M	2
16	13556	QUICK CPLR FFN06-12SAE-F	1
17	13557	QUICK CPLR FFN06-12SAE-M	1
18	D1193	FTG 6-6 FFSS-MORB STRAIGHT	4
19	C2248	LOOM 1.00 SPIRAL WRAP POLYETHYLENE	1
20	12171	FTG 6-6 MFS-MFS SWIVEL STRAIGHT	2
21	33743	FTG 6-6 FFSS-MORB STRAIGHT	1
22	53479	LOOM 1.00 ID SPIRAL WRAP POLYETHYLENE	4
23	C1111	FTG 10-6 MORB-FORB STRAIGHT REDUCER	4
24	D0107	FTG 6-6-6 MFS-MFS-FFSS BRANCH TEE	1
25	C1854	FTG 6-8 MFS-MORB STRAIGHT	2
26	C2345	FTG 6-6-6 MFS-MFS-MAORB TEE	1

**PAGE LEFT INTENTIONALLY BLANK**

# Chapter 3- Assembly Drawings

## CHAPTER CONTENTS

TM12154 CRP Assembly (128725).....	16
TM12154 RP Assembly (128726) .....	20
Decal Placement (44525) .....	25

# TM12154 CRP Assembly - PN 128725

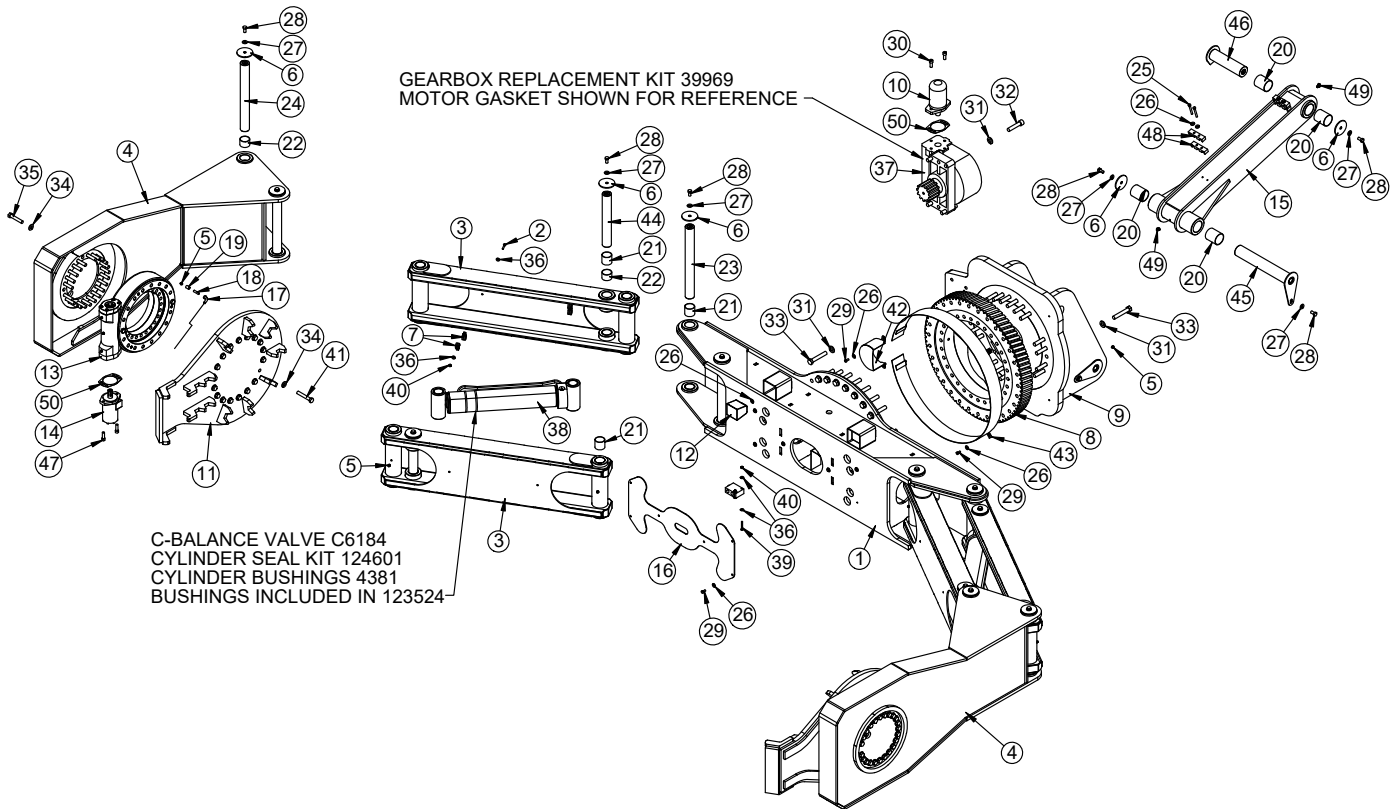
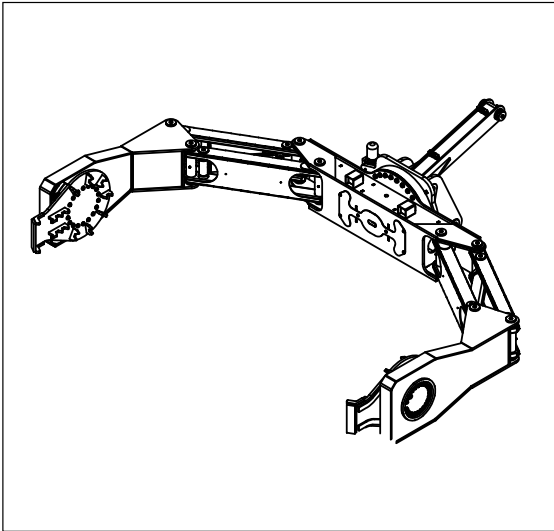

ROUTE HARNESS WITH HOSE THRU SPIRAL WRAP

**NOTE:**  
FLOW DIVIDER & MOTOR GASKET SHOWN FOR REFERENCE

# TM12154 CRP Assembly - PN 128725 Parts List

PN 128725			
ITEM	PART	DESCRIPTION	QTY
1	101543	BODY TM12154 V4	1
2	0220	CAP SCR 0.25-20X1.50 HHGR5	4
3	77178	LINK TM12154 V3 INSIDE	4
4	77221	ARM TM12154 V3 CONT ROT PADS	2
5	C1592	ZERK 1/8 NPT STRAIGHT	12
6	8377	PIN CAP 0.56X3.50X0.19 YZ	27
7	7623	CLAMP 1.00 RUBBER	8
8	22258	TURNTABLE BEARING 450-05110-1	1
9	77227	BASE TM12154 V3	1
10	5311	MOTOR HYD ROSS MG140611AAAB	1
11	77226	PAD TM12154 V3	2
12	78431	LIGHT FLOOD LED 3.2X2.9 850LM 16W 10-30V	2
13	69742	BEARING SWING DRIVE 14 IN ENCLOSED KINEMATICS	2
14	22275	MOTOR HYD EATON 101-3454	2
15	77631	LINK TM12154 V3	1
16	101592	PLATE COVER BODY TM12154 V4	1
17	C2239	FTG 2-2 MP-FP STREET ELBOW 90	2
18	C2250	FTG 2-2X1.50 MP-MP NIPPLE STRAIGHT BLK	2
19	C2256	FTG CPLR PIPE 0.13	2
20	5739	BUSHING BPC40DXR48 2.50X3.00	4
21	4381	BUSHING BPC32DXR32 2.00X2.00	32
22	4380	BUSHING BPC32DXR24 2.00X1.50	16
23	77557CR	PIN 2.00X18.75 D&T ZC	4
24	9719CR	PIN 2.00X17.75 D&T ZC	4
25	C0929	CAP SCR 0.31-18X2.75 HHGR5	4
26	0343	WASHER 0.31 USS FLAT	18
27	D0790	WASHER 0.50 SAE FLAT YELLOW GR8	29
28	10172	CAP SCR 0.50-13X1.00 HHGR8	29
29	0420	CAP SCR 0.31-18X0.75 HHGR5	12
30	D1307	CAP SCR 0.50-13X1.25 SH	2
31	17150	WASHER 0.75 SAE FLAT YELLOW GR9	50
32	11298	CAP SCR 0.75-10X3.50 SH	4
33	17149	CAP SCR 0.75-10X4.50 HHGR9	46
34	C5902	WASHER 0.63 SAE FLAT YELLOW GR8	82
35	D1312	CAP SCR 0.63-11X3.50 HHGR8	46
36	0340	WASHER 0.25 USS FLAT	16
37	6537	GEAR BOX 015-00120-1	1
38	123524	CYLINDER 4.00X18.63	2
39	0481	CAP SCR 0.25-20X2.00 HHGR5	4
40	0333	NUT 0.25-20 HHGR5 NYLOC	8
41	77555	CAP SCR 0.63-11X4.00 HHGR8 W/RED PATCH	36
42	22272	GUARD TTB TM14160B PC BLACK	1
43	22268	GEAR GUARD TM14160B PC BLACK	1

# TM12154 CRP Assembly - PN 128725 Parts List

PN 128725			
ITEM	PART	DESCRIPTION	QTY
44	17971CR	PIN 2.00X13.75 D&T ZC	4
45	41681CR	PIN TEAR DROP 2.50X16.13 ZC	2
46	41683CR	PIN TEAR DROP 2.50X9.38 ZC	1
47	62484	CAP SCR 12MMX40MM SH	4
48	70964	CLAMP 3 HOSE 0.38 HYD 28000	4
49	C1597	ZERK 1/8 NPT 90 DEG	2
50	21151	GASKET MOTOR 008-10056-1	3
51	35111	VALVE COMB DIV FD50-44-6T-N-44	1
52	105063	VALVE SOLND 2 POS 3 WAY SV10-34-6T-N-12DR	1

PN 128725 ITEMS NOT SHOWN	
PART	DESCRIPTION
21409	WIRE HARNESS FLOOD LIGHT TM14160
44525	DECAL KIT TM12154
78017	HYD KIT TM12154 V3 90 DEG
D0240	FTG 4-2 CPRSN-MP 90
D1810	TBE AIR SAEJ844 TYPE A .25 (RM)
D1345	FTG 4-2 CPRSN-MP STRAIGHT
22161	FTG 2-2 FP-FP CPLR STRAIGHT BRASS
56589	ZERK 1/8 NPT STRAIGHT LONG THREAD
9752	CONNECT 2P SHRD WEATHER PACK
9756	CONTACT M 20-18GA WEATHER-PACK
8384	CABLE SEAL 18-16GA GREEN METRI-PACK 280
90383	MANUAL TM12154

**PAGE LEFT INTENTIONALLY BLANK**

# TM12154 RP Assembly - PN 128726

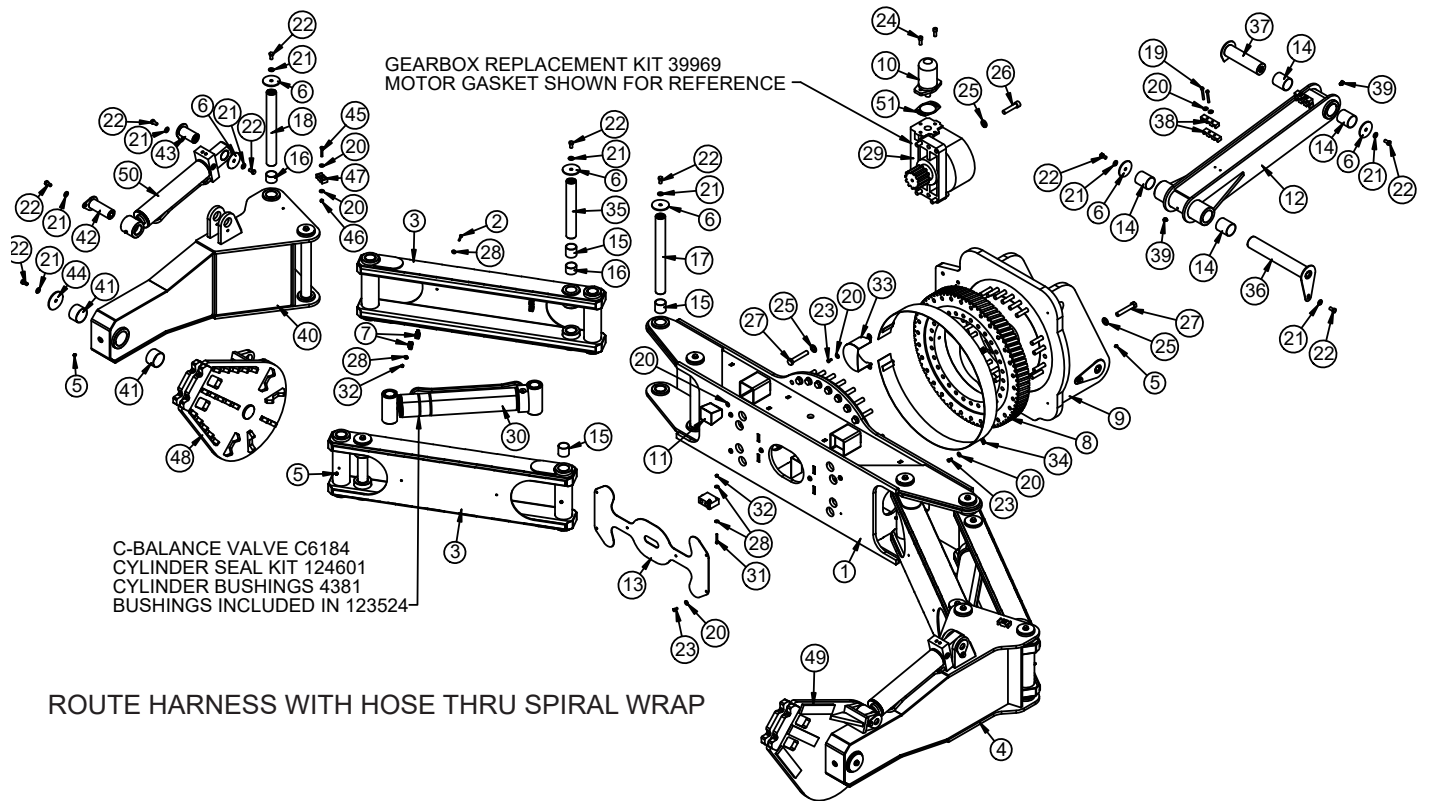
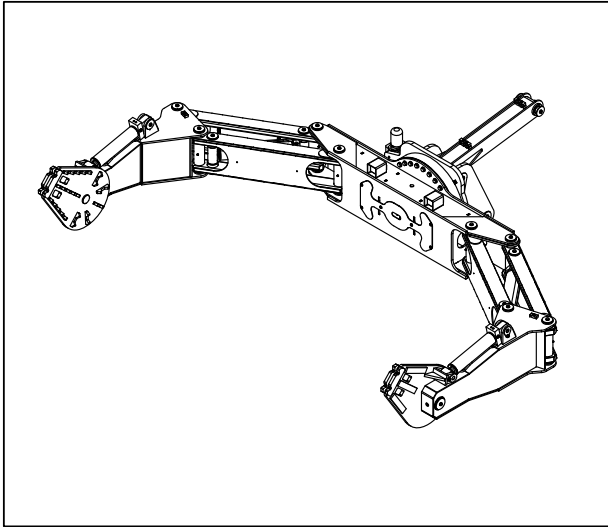

**NOTE:**  
FLOW DIVIDER & MOTOR GASKET SHOWN FOR REFERENCE



# TM12154 RP Assembly - PN 128726 Parts List

PN 128726			
ITEM	PART	DESCRIPTION	QTY
1	101543	BODY TM12154 V4	1
2	0220	CAP SCR 0.25-20X1.50 HHGR5	4
3	77178	LINK TM12154 V3 INSIDE	4
4	77855	ARM TM12154 V3 CS	1
5	C1592	ZERK 1/8 NPT STRAIGHT	12
6	8377	PIN CAP 0.56X3.50X0.19 YZ	29
7	7623	CLAMP 1.00 RUBBER	8
8	22258	TURNTABLE BEARING 450-05110-1	1
9	77227	BASE TM12154 V3	1
10	5311	MOTOR HYD ROSS MG140611AAAB	1
11	78431	LIGHT FLOOD LED 3.2X2.9 850LM 16W 10-30V	2
12	77631	LINK TM12154 V3	1
13	101592	PLATE COVER BODY TM12154 V4	1
14	5739	BUSHING BPC40DXR48 2.50X3.00	4
15	4381	BUSHING BPC32DXR32 2.00X2.00	32
16	4380	BUSHING BPC32DXR24 2.00X1.50	16
17	77557CR	PIN 2.00X18.75 D&T ZC	4
18	9719CR	PIN 2.00X17.75 D&T ZC	4
19	C0929	CAP SCR 0.31-18X2.75 HHGR5	4
20	0343	WASHER 0.31 USS FLAT	22
21	D0790	WASHER 0.50 SAE FLAT YELLOW GR8	37
22	10172	CAP SCR 0.50-13X1.00 HHGR8	37
23	0420	CAP SCR 0.31-18X0.75 HHGR5	12
24	D1307	CAP SCR 0.50-13X1.25 SH	2
25	17150	WASHER 0.75 SAE FLAT YELLOW GR9	50
26	11298	CAP SCR 0.75-10X3.50 SH	4
27	17149	CAP SCR 0.75-10X4.50 HHGR9	46
28	0340	WASHER 0.25 USS FLAT	16
29	6537	GEAR BOX 015-00120-1	1
30	123524	CYLINDER 4.00X18.63	2
31	0481	CAP SCR 0.25-20X2.00 HHGR5	4
32	0333	NUT 0.25-20 HHGR5 NYLOC	8
33	22272	GUARD TTB TM14160B PC BLACK	1
34	22268	GEAR GUARD TM14160B PC BLACK	1
35	17971CR	PIN 2.00X13.75 D&T ZC	4
36	41681CR	PIN TEAR DROP 2.50X16.13 ZC	2
37	41683CR	PIN TEAR DROP 2.50X9.38 ZC	1
38	70964	CLAMP 3 HOSE 0.38 HYD 28000	4
39	C1597	ZERK 1/8 NPT 90 DEG	2
40	77558	ARM TM12154 V3 SS	1
41	0865	BUSHING BPC48DXR32 3.00X2.00	4

# TM12154 RP Assembly - PN 128726 Parts List

PN 128726			
ITEM	PART	DESCRIPTION	QTY
42	41634CR	PIN TEAR DROP 2.00X5.50 ZC	2
43	41632CR	PIN TEAR DROP 2.00X3.88 ZC	2
44	13315	PIN CAP 0.56X4.00X0.19 YZ	2
45	0488	CAP SCR 0.31-18X2.00 HHGR5	2
46	0342	NUT 0.31-18 HHGR5 NYLOC	2
47	8621	CLAMP HOSE/TUBE AG-3	2
48	64155	PAD TM12154 SS V2	1
49	64158	PAD TM12154 CS V2	1
50	41567	CYLINDER 3.50X13.25	2
51	21151	GASKET MOTOR 008-10056-1	1
52	35111	VALVE COMB DIV FD50-44-6T-N-44	2

**PAGE LEFT INTENTIONALLY BLANK**

# Decal Placement - PN 44525

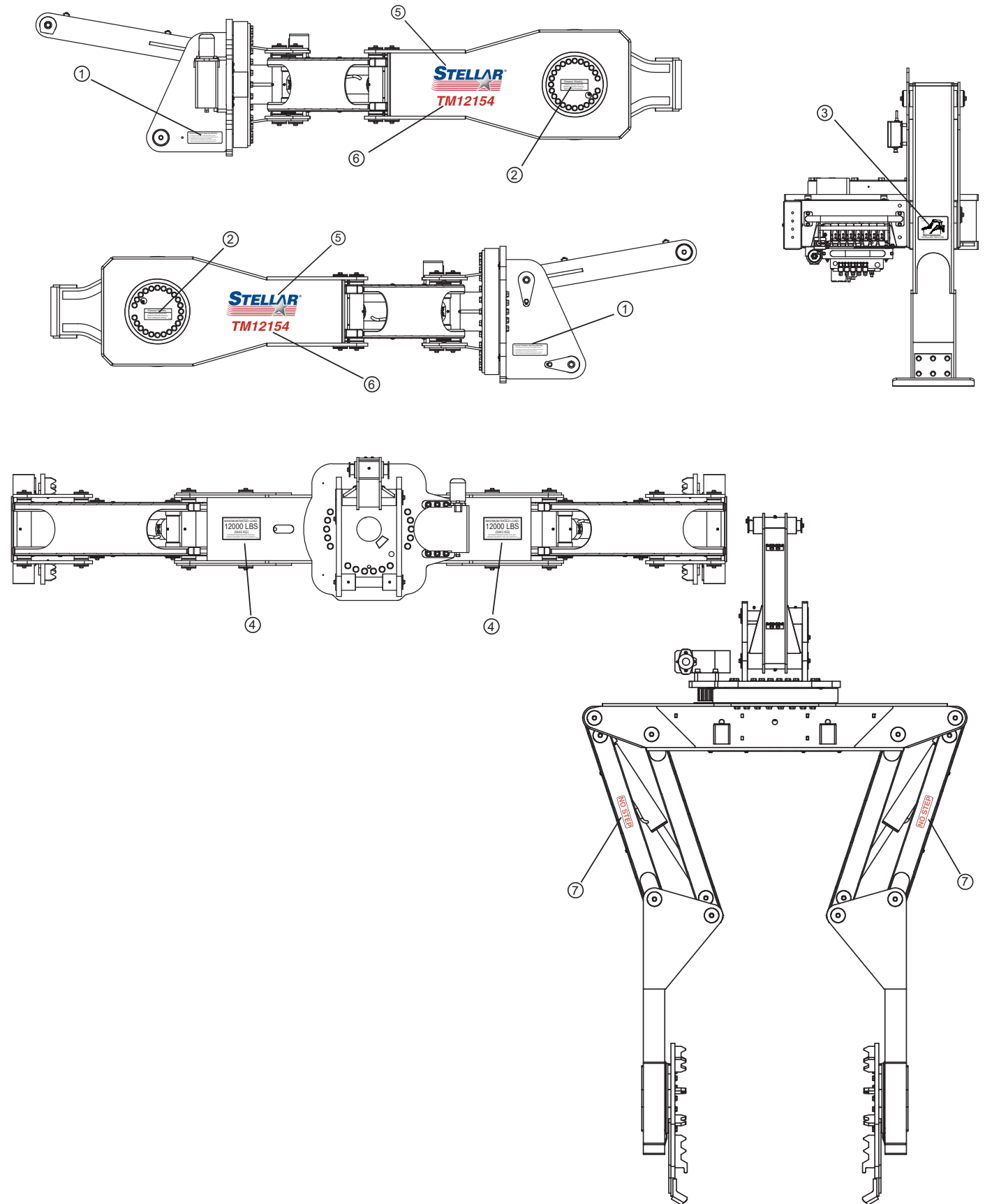

## Decal Placement - PN 44525 Parts List

PN 44525			
ITEM	PART	DESCRIPTION	QTY
1	22617	DECAL ROTATION BEARING	2
2	22618	DECAL GREASE WEEKLY	2
3	43474	DECAL CAPACITY CHART	2
4	43475	DECAL RATED LOAD	2
5	52681	DECAL STELLAR LOGO 6.00X16.50	2
6	54600	DECAL TM12154 IDENTIFICATION	2
7	24982	DECAL NO STEP 5.00X1.25	2
REV. C 20220114:MEL			







Subject to Change without Notification.  
© 2022 Stellar Industries, Inc.