

Piston Single-Stage Compressor Operation Manual

Safety • Operation • Maintenance • Troubleshooting

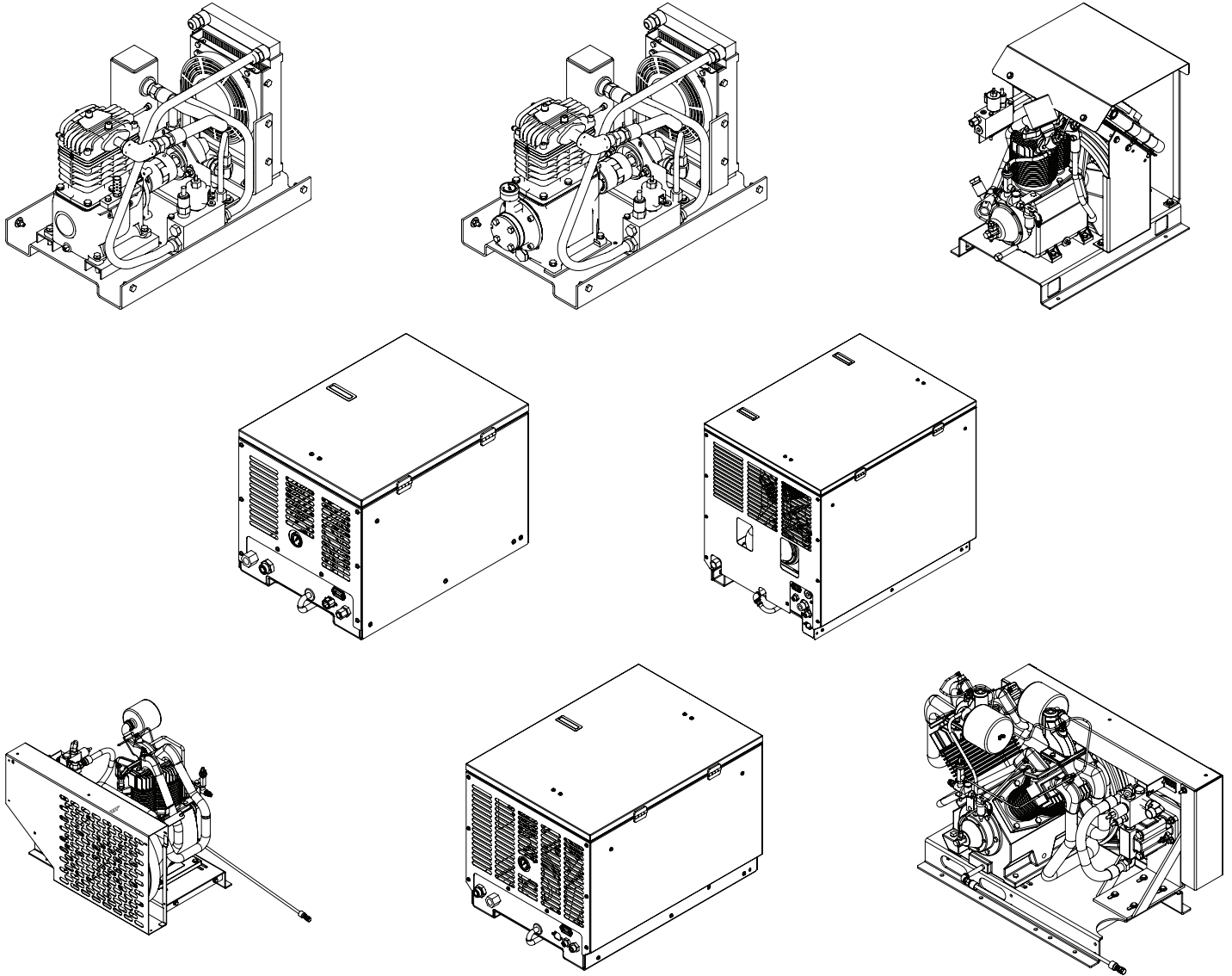

Stellar Industries Inc.
740 North State Street
PO Box 169
Garner, IA 50438
800-392-3015

www.stellarindustries.com

Subject to Change without Notification.
© 2023 Stellar Industries Inc.

Rev 1
PN 92631

Table of Contents

Introduction	iv
Chapter 1 - Operation.....	1
General Operation	1
Operator Requirements	1
Before Start-Up.....	2
Start-Up Procedure.....	2
Piston Compressor Air Operations	3
Safety Decals of Note	3
Chapter 2 - Maintenance	5
General Maintenance Guidelines	5
Service Intervals	6
Oil Level.....	7
Changing the Oil	7
Changing the Oil (cont.).....	8
Air Filter.....	8
Hydraulic Oil Cooler/Compressor Oil Cooler	9
Chapter 3 - Troubleshooting.....	11

For Technical Questions, Information, Parts, or Warranty, Call Toll-Free at

800-321-3741

Hours: Monday - Friday, 8:00 a.m. - 5:00 p.m. CST

Or email at the following addresses:

Technical Questions, and Information: service@americaneagleacc.com

Order Parts: parts@americaneagleacc.com

Warranty Information: warranty@americaneagleacc.com

Introduction

Stellar Industries® Air Compressors are designed to provide safe and dependable service for a variety of operations. With proper use and maintenance, these air compressors will operate at peak performance for many years.

To promote this longevity, carefully study the information contained in this manual before putting the equipment into service. Though it is not intended to be a training manual for beginners, this manual should provide solid guidelines for the safe and proper usage of the air compressor.

Once you feel comfortable with the material contained in this manual, strive to exercise your knowledge as you safely operate and maintain the air compressor. This process is vital to the proper use of the unit.

A few notes on this manual:

A copy of this manual is provided with every air compressor and can be found in the hard plastic manual case that is installed on the chassis. A copy of this manual shall remain with the air compressor at all times.

Throughout the manual, three signal words will be used to bring attention to important items:

NOTICE

A NOTICE signal word indicates a practice not related to physical injury.

⚠ WARNING

A WARNING signal word indicates a hazardous situation which, if not avoided, could result in death or serious injury.

⚠ DANGER

A DANGER signal word indicates a hazardous situation which, if not avoided, will result in death or serious injury.

Information contained within this manual does not cover all maintenance, operating, or repair instructions pertinent to all possible situations. Please be aware that some sections of this manual contain information pertaining to Stellar Industries® manufactured air compressors in general and may or may not apply to your specific model.

This manual is not binding. Stellar Industries reserves the right to change, at any time, any or all of the items, components, and parts deemed necessary for product improvement or commercial/production purposes. This right is kept with no requirement or obligation for immediate mandatory updating of this manual.

In closing:

If more information is required or technical assistance is needed, or if you feel that any part of this manual is unclear or incorrect, please contact the Stellar Industries Customer Service Department by phone at 800-392-3015 or email at service@americaneagleacc.com.

Chapter 1 - Operation

Safety should be the number one thought on every operator's mind. Three factors should exist for safe operation: a qualified operator, well-maintained equipment, and the proper use of this equipment.

This chapter contains information regarding the safety and operation of Stellar Industries® manufactured air compressors and should be read and understood completely by everyone working with or near the air compressor before putting the unit into operation.

⚠ WARNING Failure to follow operating, maintenance, or safety instructions can result in death or serious injury.

General Operation

It is the responsibility of the owner to instruct the operator in the safe operation of the equipment and to provide the operator with properly maintained equipment.

⚠ WARNING Stellar Industries® Air Compressor operators must conform to the qualifications specified in this manual. Trainees or untrained persons shall be under the direct supervision of qualified persons.

Operators shall consult with the owner of the equipment regarding current safety regulations and required personal protective equipment.

Operators should never operate the air compressor while under the adverse influence of alcohol, drugs, or medication.

Please take note that Stellar Industries is not liable for accidents incurred by the air compressor because of non-fulfillment from the operator's side of current rules, laws, and regulations.

Operator Requirements

Operation is limited to the following people:

- A. Qualified individual.
- B. Trainees under direct supervision of the qualified individual.
- C. Test or maintenance individual.
- D. Air compressor inspector.

Qualified individuals must:

- A. Demonstrate the ability to understand all decals, the owner's manual, and any other information required for safe operation of the air compressor.
- B. Be able to demonstrate the ability to safely control the air compressor.
- C. Know all safety regulations.
- D. Be responsible for maintenance requirements.
- E. Understand and be fully capable of implementing all emergency procedures.
- F. Understand all operating procedures as outlined by this manual.

Before Start-Up

Inspect unit for any visible signs of damage. Check hoses (air and hydraulic) for weak or worn condition and make sure that all connections are secure.

⚠ WARNING Do not operate the compressor if it is damaged, improperly adjusted or not assembled properly.

⚠ WARNING Do not operate the compressor with any of the guards removed.

Check the oil level in the compressor (See Section “Changing the Oil”). If oil is needed, use Stellar Industries® Synthetic Compressor Oil (P/N C0087) or an equivalent synthetic oil.

Check the air intake filter to make certain that it is clean and unobstructed. A dirty air filter is a possible cause of reduced air output.

⚠ WARNING The air taken in by the air compressor must be free of flammable fumes and vapors.

Cold Start-Up Procedure

If operating in a cold environment, oils can become thick and lead to hard starts.

1. If your unit is equipped with a cold weather kit, engage it when driving to a site or 20 minutes prior to starting the unit.
2. Turn on hydraulics and allow to run for 5-10 minutes.
3. Engage the compressor switch.
4. Proceed with normal start up procedure.

Start-Up Procedure

To use the compressor:

1. Start the vehicle engine and engage the hydraulic system.
2. The compressor can now be activated using the compressor switch. This energizes the hydraulic solenoid sending oil to the hydraulic drive motor and starts the compressor. The system will now function automatically.

⚠ WARNING Never use the compressor as a booster pump and/or to compress a medium other than atmospheric air.

3. Once engaged, adjust the engine speed control to ensure that the compressor speed does not exceed 1300 rpm under load. Adjustment instructions are provided with the speed control unit.

Piston Compressor Air Operations

If adjustment is necessary for cable operated speed controls, loosen the jam nut on the cable end, make the adjustment and retighten the jam nut.

For electronic operated speed controls, adjust speed adjustment screw as needed to set RPM.

For setting engine RPM through the chassis ECM, contact local chassis dealer.

When the air pressure falls below 120 PSI, the 12 volt electric solenoid opens allowing hydraulic oil to flow to the hydraulic drive motor then back to the manifold and through the oil cooler assembly. Once the air pressure reaches 150 PSI the solenoid closes shutting off the oil flow to the motor and diverts the oil to the oil cooler.

With the compressor engaged, the main cooling system, which consists of an oil cooler, electric fan motor and fan continually runs drawing ambient air through the cooler fins and across the fan assembly discharging heated air past the compressor and out the cover assembly.







NOTICE

Duty cycle on Piston Compressors is 50:50 over 10 minutes.

Safety Decals of Note

Safety decals serve to inform the viewer of the hazard type, how to avoid the hazard, and the consequences of not avoiding the hazard.

Decals are considered safety equipment. They must be maintained, as would other safety devices. All safety instruction plates, notices, load charts and any other decal applied to the air compressor or vehicle must be kept legible and in good condition. Replace any decals that are missing, damaged, or illegible.

 WARNING		Failure to obey the following can result in death or serious injury:	
			
<p>Untrained Operator Hazard</p> <p>Read and understand all manuals and safety signs before operating or servicing this equipment.</p>	<p>Breathing Hazard</p> <p>Do not use air from compressor for breathing or food processing.</p>	<p>Burn Hazard</p> <p>Do not touch any internal surfaces during or shortly after operation.</p>	<p>Crush Hazard</p> <p>Keep clear while unit is in operation. Do not operate unit without cover attached.</p>
		<p>Pressure Hazard</p> <p>Do not remove caps, plugs, or other components while unit is running or has pressure in tank. Disconnect power and relieve all pressure prior to maintenance.</p>	
<p>Fluid Hazard</p> <p>Do not search for leaks with hands or other body parts. Relieve pressure before disconnecting lines. Tighten all connections before applying pressure.</p>			

This page intentionally left blank.

Chapter 2 - Maintenance

Maintenance is an important part of extending the life of any Stellar Industries® Air Compressor. Performing key maintenance items on a scheduled program will prevent unnecessary downtime.

General Maintenance Guidelines

Before performing any maintenance to the air compressor, consider the following:

- **⚠ WARNING** Only qualified service personnel are to perform maintenance on the Air compressor. Never modify or alter any of the equipment, whether mechanical, electrical, or hydraulic, without explicit approval from Stellar Industries.
- Shut off the engine and disengage the PTO.
- Place all controls in the off position and secure operating features from inadvertent motion.
- Disable all power to the air compressor and remove any stored energy.
- Before performing any maintenance on the compressor, place a warning tag on the hydraulic power source or disconnect the hoses from the compressor motor to prevent accidental startup of the compressor.
- **⚠ WARNING** Do not disconnect hydraulic hoses while there is still pressure in those components.
- **⚠ WARNING** Do not touch the air compressor or plumbing until the unit has cooled down. The surface of the air compressor and the plumbing between the compressor and the cooler may reach temperatures above 150 degrees.
- Replace parts with Stellar Industries® approved parts only.
- Keep the air compressor clean and free from grease build-up, oil and dirt to prevent slippery conditions.
- Label or tag parts when disassembling.
- Immediately repair or have repaired any components found to be inadequate.
- Always connect hoses to the compressor before energizing the power source. Be sure all hose connections are tight.
- **NOTICE** Do not attempt to adjust or disable the compressors air pressure relief valve. This valve protects the compressor in the event of blockage or air control system malfunction.

Service Intervals

The following table is a list of routine maintenance items, including service intervals. If working in dusty, dirty, or hot environments, reduce the recommended time intervals between servicing by half for oil and filter changes. Service intervals are listed as hours, days, or weeks, whichever occurs first. Stellar Industries recommends that these service intervals be followed. Before performing any maintenance function, turn off compressor, hydraulic system, truck engine and remove keys to assure that compressor is not started. Be sure all air pressure in unit is relieved. Failure to do so may result in injury or equipment damage.

Maintenance Schedule	Daily	Weekly	Monthly	Hourly
Drain air tanks.	<input checked="" type="checkbox"/>	<input checked="" type="checkbox"/>	<input checked="" type="checkbox"/>	<input checked="" type="checkbox"/>
Check compressor case oil level.	<input checked="" type="checkbox"/>			
Check fittings and airlines.	<input checked="" type="checkbox"/>			
Check hydraulic fluid level.	<input checked="" type="checkbox"/>			
Inspect and clean air intake filters.		<input checked="" type="checkbox"/>		
Clean and operate safety vavles.		<input checked="" type="checkbox"/>		
Clean cooling fins on radiator.		<input checked="" type="checkbox"/>		
Inspect check valve.		<input checked="" type="checkbox"/>		
Replace hydraulic filter.			6	
Replace air filters.			3	
Tighten all fittings and fasteners.			3	
Check all electrical connections.			3	
Check compressor reed valves.				250
Inspect and clean air check valve.				250

General preventative maintenance includes maintaining proper fluid level in both systems and the general cleanliness of the equipment. Proper fluids according to the specifications are required.

USE AE SYNTHETIC COMPRESSOR OIL P/N 95179. SEE MODEL MANUAL FOR COMPRESSOR CRANKCASE CAPACITY.

Oil Level

The oil level in the compressor case is an important factor for the operational reliability of the system.

Check Intervals:

1. Before starting unit.
2. Every 100 operating hours

Check Procedures:

1. Turn off the compressor, hydraulic system and truck engine to ensure that compressor is not started.
2. Wait for one full minute.
3. Slowly unscrew the oil fill cap on the compressor case (also referred to as the separator receiver).
4. Check the oil level using the dipstick.
5. If the oil level is under the minimum level, add oil to maximum level as shown.
6. Replace cap and hand tighten. Unit is ready to be put into service.

Changing the Oil

Change the oil with the compressor at operating temperature of 140-175 degrees F (60-80 degrees C). Oil change should happen once every 1000 hours or 6 months.

⚠ WARNING Compressor must be stopped and all air receivers discharged before changing oil. Compressor oil is hot and can cause burns.

1. Turn off the compressor, hydraulic system and truck engine to ensure that compressor is not started.
2. Discharge air receiver.
3. Wait for one full minute.
4. Slowly unscrew the oil fill cap on the compressor case.
5. Place a container under the oil drain pipe and carefully unscrew the oil drain cap.
6. Drain the oil from the compressor case, then replace and tighten oil drain cap.
7. Refill with oil to maximum level and replace oil fill cap. Check compressor model manual for oil capacity.
8. Operate compressor for 3 minutes.
9. Check oil and fill to maximum if necessary.

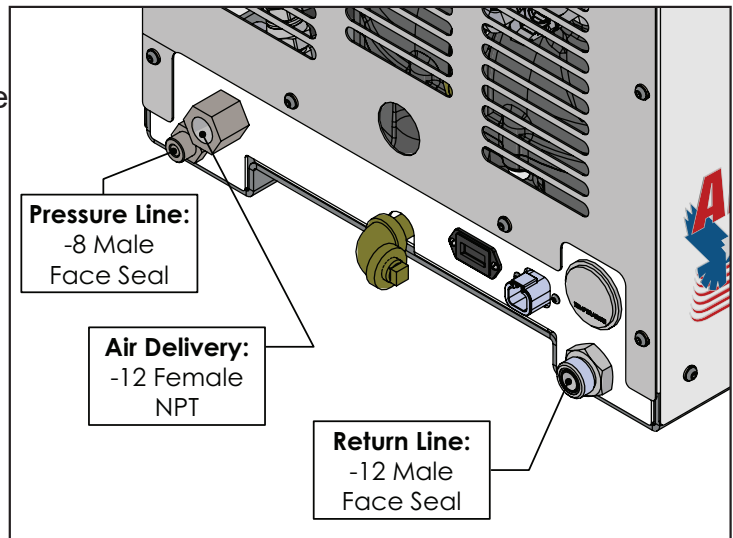

Changing the Oil (cont.)

Oil Recommendations

Piston compressors must be operated using the most suitable oil for operation. The compressor manufacturer must approve this oil for use. The oil must also be suitable for use in unfavorable conditions such as: contamination of the intake air by gases, solvent vapors, exhaust gases, and high ambient temperature conditions.

Suitable types and brands of oil may be specified on request. Suitable piston compressor oils can be mineral oils, synthetic oils, and biological degradable oils.

The substances and materials used in the compressor such as seals must be taken into account when selecting the types of oil. Corrosion or other material degradation must not occur.

NOTICE Do not mix different types of oil.

NOTICE In the case of ambient temperatures close to freezing, prevent the unit from freezing.

Pipeline Materials:

The oil used in piston compressors can degrade plastics used in air pipelines.

Oil Requirements

High aging stability

High disperse capacity

Low emulsification tendency

Flash point: above 400°F / 200°C

Pour-point: 5° below lowest ambient temperature minimum

Minimum foaming

High corrosion protection

Hydraulic or turbine oil

Basic oil: solvate

Operating temperature: up to 230°F / 110°C

Viscosity class: ISO 46 or ISO VG 68

Viscosity at 104°F / 40°C: ca. 42-50 mm²/s (cST)

Air Filter

The air filter should be changed every 500 hours or 3 months of operation. The filter may require changing or cleaning more frequently if the compressor is operated in a dusty environment.

Maintenance Procedure:

1. Turn off the compressor, hydraulic system and truck engine to ensure that compressor is not started.
2. Open filter lid and carefully remove filter.
3. Carefully remove dust from the intake housing.
4. Clean and install or install new filter:
 - Clean filter by tapping outside of filter on a hard surface.
 - Clean filter with compressed air by blowing from the inside to the outside. Limit air pressure to 75 psi.
5. Close filter lid.
6. Test run compressor.

NOTICE Any dirt or debris that enters the compressor intake when the air filter is removed can cause irreversible damage.

Hydraulic Oil Cooler/Compressor Oil Cooler

For reliable operation and longevity of both compressor and hydraulic system, the cooler should be kept clean. The compressor system is protected from operation at high temperature by a switch gauge. If the compressor shuts down or is operating close to the shut down temperature, the cooler should be cleaned. The cooler can be cleaned with compressed air, pressure washer or steam cleaner.

Maintenance Procedure

1. Turn off the compressor, hydraulic system and truck engine to ensure that compressor is not started.
2. Discharge the receiver.
3. Remove the shroud.
4. Drain oil from the compressor.
5. Disconnect:
 - a. Lines to the cooler.
 - b. Lines to the thermo valve.
 - c. Electrical connection to the fan.
6. Remove the cooler.
7. Remove the fan shroud and fan from the cooler.
8. Cap the hydraulic fittings on the cooler and thermo valve.
9. Clean cooler.
10. Reinstall the cooler in reverse order.
11. Refill with oil.
12. Test run compressor and check operating temperature.
13. Check oil level and fill if necessary.

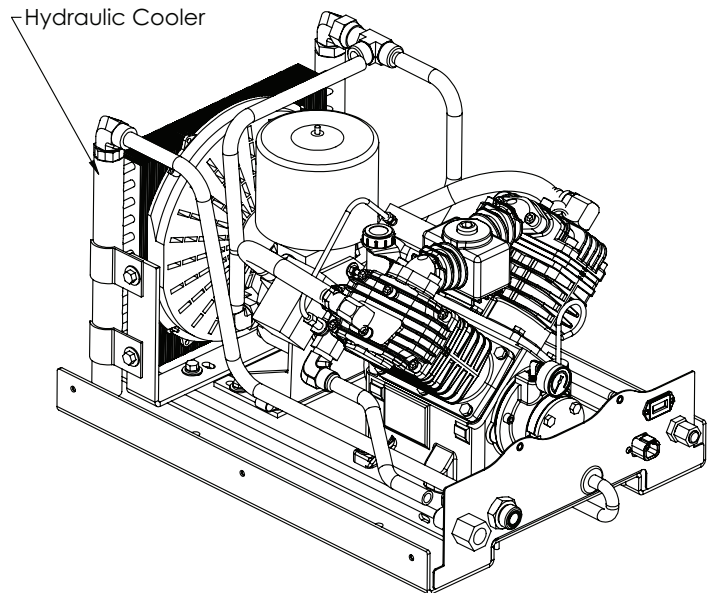

This page intentionally left blank.

Chapter 3 - Troubleshooting

If symptoms of poor performance develop, the following chart can be used as a guide to investigate and correct the problem. When diagnosing faults in operations of the air compressor, always check that the hydraulic power source is supplying the correct hydraulic flow and pressure that is listed in the compressor specification section of the compressor model specific manual. As always, feel free to contact Stellar Industries® Customer Service at 1-800-321-3741

Problem	Possible Cause	Solution
Compressor locks up at 110 psi and higher while under load: Note: When checking hydraulic pump flow, make sure the air tank is closed and the compressor is running.	Weak Hydraulic Motor.	If the Hydraulic pump is supplying the recommended amount of fluid to the hydraulic motor, replace the hydraulic motor.
	Faulty Hydraulic Pump.	If the pump pressure is below the recommended GPM, replace the Hydraulic pump if necessary.
	Oil Pressure is low.	If the oil pressure gauge is reading in the red area, the oil pressure is low. See the Low Oil Pressure entry in this troubleshooting section.
Compressor will not operate:	Air receiver is full.	Drain and activate pressure switch.
	12 Volt power is not going to the line side of the pressure switch.	If there is no power going to the line side of the pressure switch, trace the wire back to the power source.
	Faulty Pressure Switch.	If there is no power going to the solenoid valve, replace the pressure switch.
	Hydraulic Lines not installed correctly.	Reinstall hydraulic lines.
	Air Couplers or hoses are blocked.	Locate and remove restriction.
	Inline Check-Valve is leaking.	Disassemble, clean, and reinstall or replace.
	Faulty Solenoid Valve.	If there is power going to the pressure switch, press down on the solenoid valve bypass button. If the compressor starts to operate, replace the solenoid valve.
	Compressor is locked up.	Remove the coupler and lovejoy between the compressor pump and the hydraulic motor. Turn the compressor over by hand. If the compressor turns over freely, the pump is ok. This indicates there is a possible hydraulic problem.
	Hydraulic motor malfunctioning.	Inspect and repair.
Hydraulic pump malfunctioning.	Check flow and pressure settings.	

Problem	Possible Cause	Solution
Compressor runs hot: (Heads above 350°F)	Dirty intake filter.	Clean filter assembly.
	Low oil Level.	Add oil if needed.
	Inline check-valve leaking.	Disassemble, clean, and re-install.
	Blown Head or Reed Valve Gasket.	Replace Gasket.
	Malfunctioning reed valve.	Inspect, clean or replace valves.
Compressor runs too slow:	Speed control not working.	Check power supply and readjust.
	Check for air hose leaks.	Tighten any hose fitting leaking.
	Hydraulic system too hot.	Reservoir too small. Add cooler to system.
	Power unit relief set too low.	Readjust relief valve.
	Hydraulic motor worn.	Replace with new motor.
	Hydraulic flow too low.	Check and reset flow.
	Malfunctioning reed valves.	Inspect, clean, or replace valves.
Compressor hesitates or stumbles at restart (115 PSI): Note: Compressor kicks out at 150 PSI and kicks back in at 115 PSI	Weak Hydraulic Pump.	If the hydraulic pump flow or pressure is below the recommended GPM or PSI to the hydraulic motor, the hydraulic pump could be weak and needs to be replaced.
	Weak Hydraulic Motor.	If the hydraulic pump is supplying the recommended GPM to the hydraulic motor, the hydraulic motor could be weak and needs to be replaced.
No lubricating oil pressure:	No oil in crankcase.	Add oil.
	Pump suction blocked.	Remove oil intake plug and inspect intake screen. Clean blockage.
	Air lock in oil pump.	Loosen oil gauge while the compressor is running. When oil begins to flow, tighten the gauge.
	Oil pump pin is broken.	Replace pin.
	Malfunctioning oil pump.	If the oil pressure gauge indicator is reading in the red area, use a 1/4" lock washer and point it flat. Remove the oil pump housing cover and place the lock washer inside the oil pump transfer bushing so it is between the pump spring and the transfer bushing. If oil pressure is still low, add one more lock washer. If two lock washers don't increase the oil pressure, replace the oil pump.

Problem	Possible Cause	
Air Output low: (Air Pressure Low)	Dirty air filter.	Inspect and clean filter.
	Insufficient torque on head bolts.	Tighten bolts to required torque.
	Intake reed valves malfunction.	If air back-flows from air filter, reed valve is faulty and needs to be replaced.
	Air line leaking.	Inspect and tighten loose hoses.
	Air consumption exceeds Compressor capacity.	Check air demand for items using the air supply.
	Air pressure switch set incorrectly.	Readjust high pressure setting.
	Intake or exhaust reed valves damaged.	Inspect and replace.
Air pressure too high:	Pressure switch not functioning correctly.	Inspect and clean.
	Internal contamination.	Inspect and clean.
	Pressure switch not adjusted correctly.	Inspect and clean.
High crankcase oil usage:	External oil leaks.	Readjust to lower pressure.
	Oil level too high.	Inspect and repair gaskets or seals and check for excess water.
	Piston rings worn or broken.	Check oil level and drain if needed.
Blowing oil from crankcase breather:	Oil level in crankcase too high.	Replace rings.
	Blown head gasket.	Check oil level and drain.
	Piston rings worn or broken.	Replace gasket.
	Hole in piston.	Replace ring.
Compressor will not stop:	Air pressure switch set incorrectly.	Replace piston.
	Leaking air hoses or fittings.	Check points and setting on switch.
	Stuck solenoid valve.	Tighten all fittings and hoses.
		Inspect and clean, replace if needed.



Subject to Change without Notification.
© 2023 Stellar Industries Inc.