

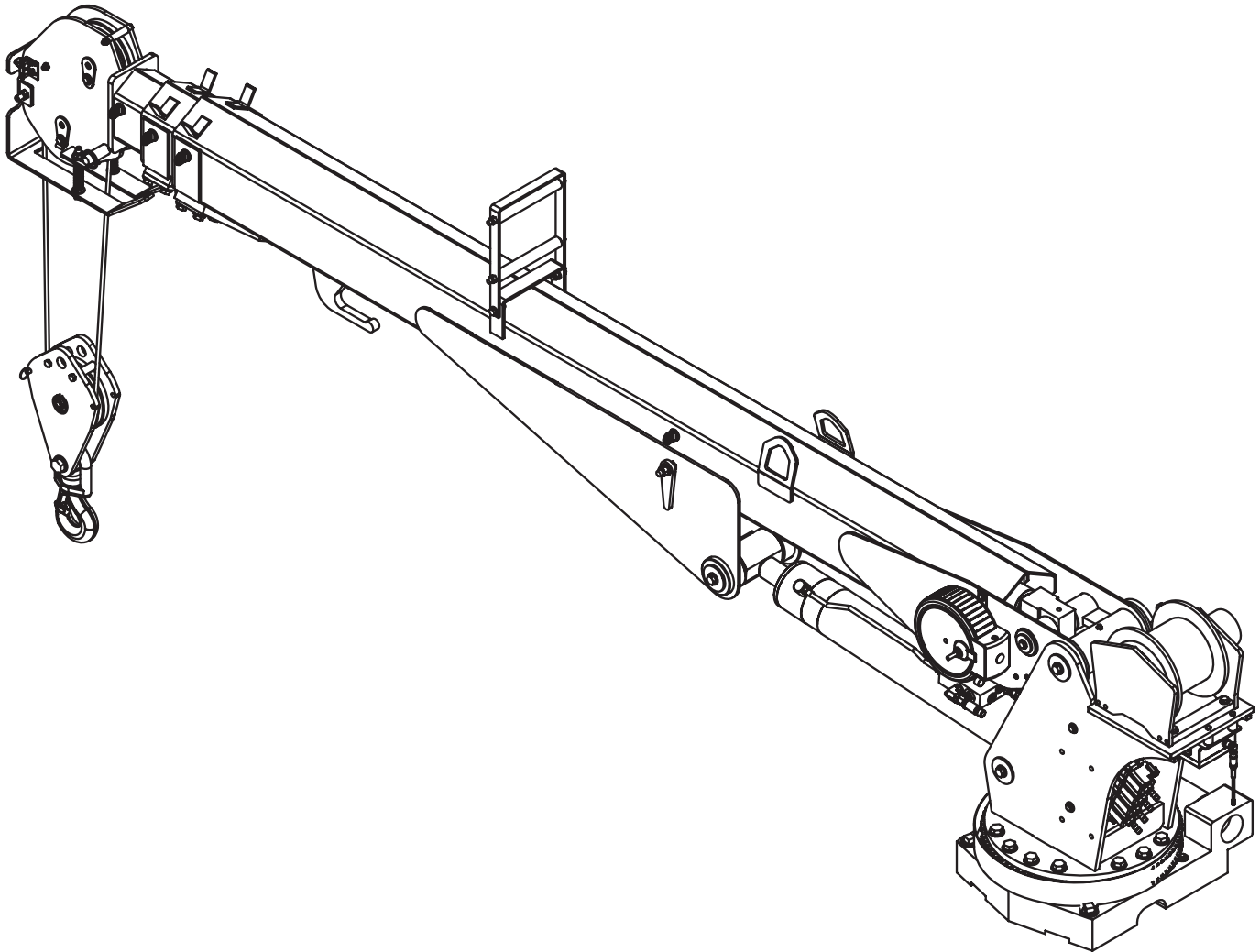

Model 6521 Telescopic Crane Owner's Manual

Installation • Assembly Drawings • Parts



Notice: A copy of this manual must remain with the equipment at all times.
For a printable download copy, please visit: www.stellarindustries.com

Stellar Industries, Inc.

190 State Street

PO Box 169

Garner, IA 50438

800-321-3741

Fax: 641-923-2811

www.stellarindustries.com

Subject to Change without Notification.
© 2023 Stellar Industries, Inc.

Rev 1
PN 94718

Serial Tag Locations / Warnings

⚠ WARNING

Operating, maintaining, and servicing a Stellar product may expose you to chemicals including, but not limited to, engine exhaust, carbon monoxide, phthalates, and lead. These chemicals are known to the State of California to cause cancer and birth defects (or other reproductive harm). To keep your exposure to a minimum, be sure to avoid breathing exhaust and service your Stellar product in a well-ventilated area while wearing gloves or washing your hands frequently. For more information, go to www.P65Warnings.ca.gov/passenger-vehicle.



www.p65warnings.ca.gov

NOTICE

Cold Weather Performance

Although clear data on cold weather performance from every steel manufacturer is not available for all types and thicknesses of steel, Stellar Industries is confident that the weldments on our products will operate to 100% of their intended purpose to temperatures down to -40° F / C.

It is recommended if Stellar manufactured equipment needs to be used in temperatures below -40° F / C, the operator should pull the unit into a climate-controlled area and allow the weldments to warm up to and then maintain a temperature above this level.

Serial Tag Location

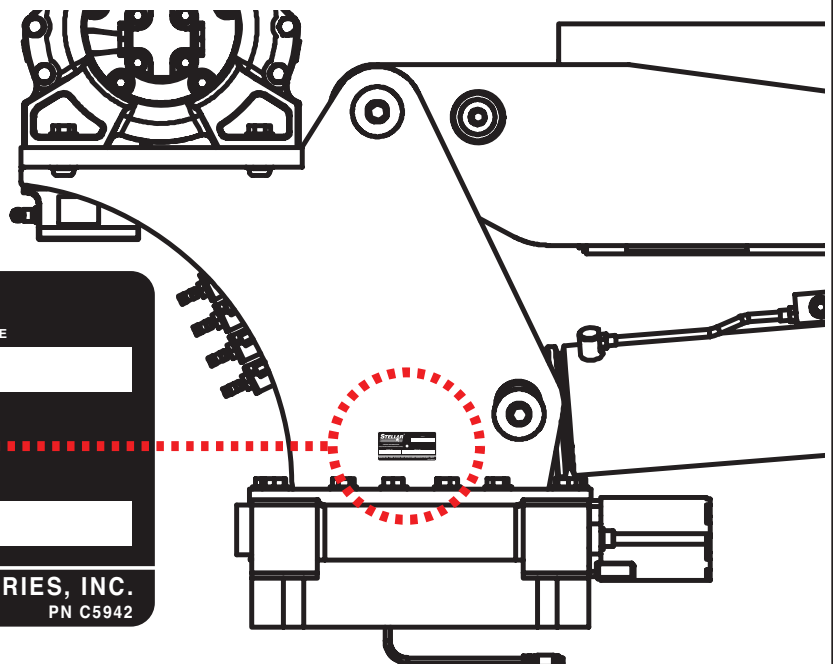
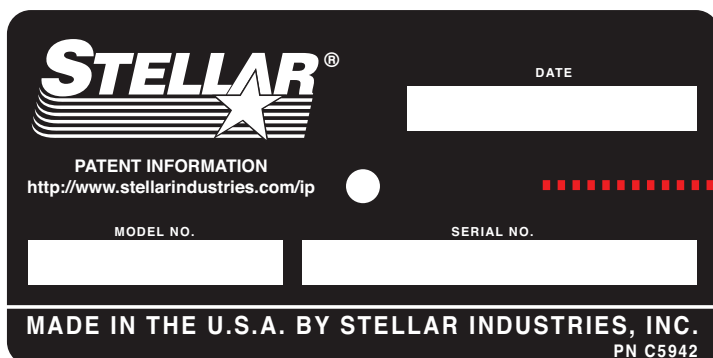

Table of Contents

Introduction	iv
Chapter 1 - Specifications	1
Model 6521 Specifications	1
Capacity Chart - Decal PN 94740	2
Dimensional Drawing 1	3
Dimensional Drawing 2	4
Chapter 2 - Installation	5
General Installation	5
Installer Notice	5
Torque Data Chart	6
Installation Overview	7
Control Kit (Cradle CDT Boost) - PN 68446	8
Control Kit (Cradle CDT Non-Boost) - PN 94716	9
Control Kit (Cradle 12V CDT Boost) - PN 94717	10
Control Kit (Cradle 12V CDT Non-Boost) - PN 68167	11
Wiring Diagram (Electrical Version)	12
Hydraulic Kit (CDT) - PN 72837	13
Hydraulic Kit (12V CDT) - PN 72839	14
Valve Bank - PN 44530	15
Valve Bank (Alternate)- PN 125254	16
Valve Bank (Alternate) - PN 125254 Parts List	17
Hydraulic Installation	18
Hydraulic System	19
Face Seal/O-Ring Size Chart	20
Stability Procedure	21
Crane Load Level Indicator	22
Decal Placement - PN 68169	23
Chapter 3 - Assembly Drawings	25
Base Assembly - PN 50364	25
Gear Bearing - PN 47869	26
Mast Assembly - PN 72819	27
Main Boom Assembly - PN 72833	28
Extension Boom Assembly - PN 58290	30
Extension Boom Assembly - PN 58290 Parts List	31
Extension Boom Assembly - PN 59146	32
Extension Boom Assembly - PN 59146 Parts List	33
Main Cylinder Assembly - PN 78434	34
Extension Cylinder Assembly (2 Hyd) - PN 49316	35
Extension Cylinder Assembly (1 Hyd/1 Manual) - PN 57936	36
Cable & Hook Assembly - PN 57597	37
Power Unit Assembly - PN 57939	38

Introduction

A copy of this manual is provided with every crane and can be found in the hard plastic manual case that is installed on the chassis. A copy of this manual shall remain with the crane at all times.

Throughout the manual, three signal words will be used to bring attention to important items:

A NOTICE signal word indicates a practice not related to physical injury.

NOTICE

A WARNING signal word indicates a hazardous situation which, if not avoided, could result in death or serious injury.

⚠ WARNING

A DANGER signal word indicates a hazardous situation which, if not avoided, will result in death or serious injury.

⚠ DANGER

Information contained within this manual does not cover operation, maintenance, or troubleshooting. Please refer to the General Light Duty Crane Manual for details on these items.

This manual is not binding. Stellar Industries, Inc. reserves the right to change, at any time, any or all of the items, components, and parts deemed necessary for product improvement or commercial/production purposes. This right is kept with no requirement or obligation for immediate mandatory updating of this manual.

In closing:

If more information is required or technical assistance is needed, or if you feel that any part of this manual is unclear or incorrect, please contact the Stellar Customer Service Department by phone at 800-321-3741 or email at service@stellarindustries.com.

**For Technical Questions, Information, Parts, or Warranty, Call Toll-Free at
800-321-3741**

Hours: Monday - Friday, 8:00 a.m. - 5:00 p.m. CST

Or email at the following addresses:

Technical Questions, and Information

service@stellarindustries.com

Order Parts

parts@stellarindustries.com

Warranty Information

warranty@stellarindustries.com

Chapter 1 - Specifications

Model 6521 Specifications

Crane Rating*:	35,000 ft-lbs (4.9 TM)	
Standard Boom Length:	11'0" (3.35 m) from CL of Crane	
Boom Extension:	1st Stage: Hydraulic 60" (152.4 cm) 2nd Stage: Hydraulic 60" (152.4 cm)	
Maximum Horizontal Reach:	21' 0" (6.40 m) from CL of Crane	
Maximum Vertical Lift:	22' 11" (6.99 m) from Crane Base	
Stowed Height (Crane Only):	33" (83.8 cm)	
Required Mounting Space:	20" x 21" (50.8 cm x 53.3 cm)	
Approximate Crane Weight:	6521 (Electric)	2H: 1480 lbs (671 kg) 1H1M: 1365 lbs (619 kg)
	6521 (Hydraulic)	2H: 1390 lbs (631 kg) 1H1M: 1275 lbs (578 kg)
Controls:	Radio control standard for all functions.	
Wire Rope:	5/16" (0.79 cm) 6X19 IWRC-DGXIP X 90' (27.73 m)	
Boom Elevation:	-10° to +80°	
Winch Specifications		
Line Pull Speed:	70 ft/min (21.34 m/min) 20 ft/min (6.10 m/min) - Electric Version	
Max. Single Part Line:	3,000 lbs (1,360 kg)	
Max. Double Part Line:	6,000 lbs (2,720 kg)	
Rotation (Worm Gear):	400° Power	
Lifting Capacity**:	6,000 lbs @ 5'10" (2,720 kg @ 1.78 m) 1,680 lbs @ 21' (760 kg @ 6.40 m)	
Power Supply:	12V Power Unit:	2 gpm @ 3,000 psi (7.6 lpm @ 207 bar)
	PTO & Pump:	8 gpm @ 3,000 psi (30.3 lpm @ 207 bar)

*Crane rating in Boost Mode. Normal crane rating is 30,000 ft-lbs (4.15 TM).

**Maximum capacities in Boost Mode.

Capacity Chart - Decal PN 94740

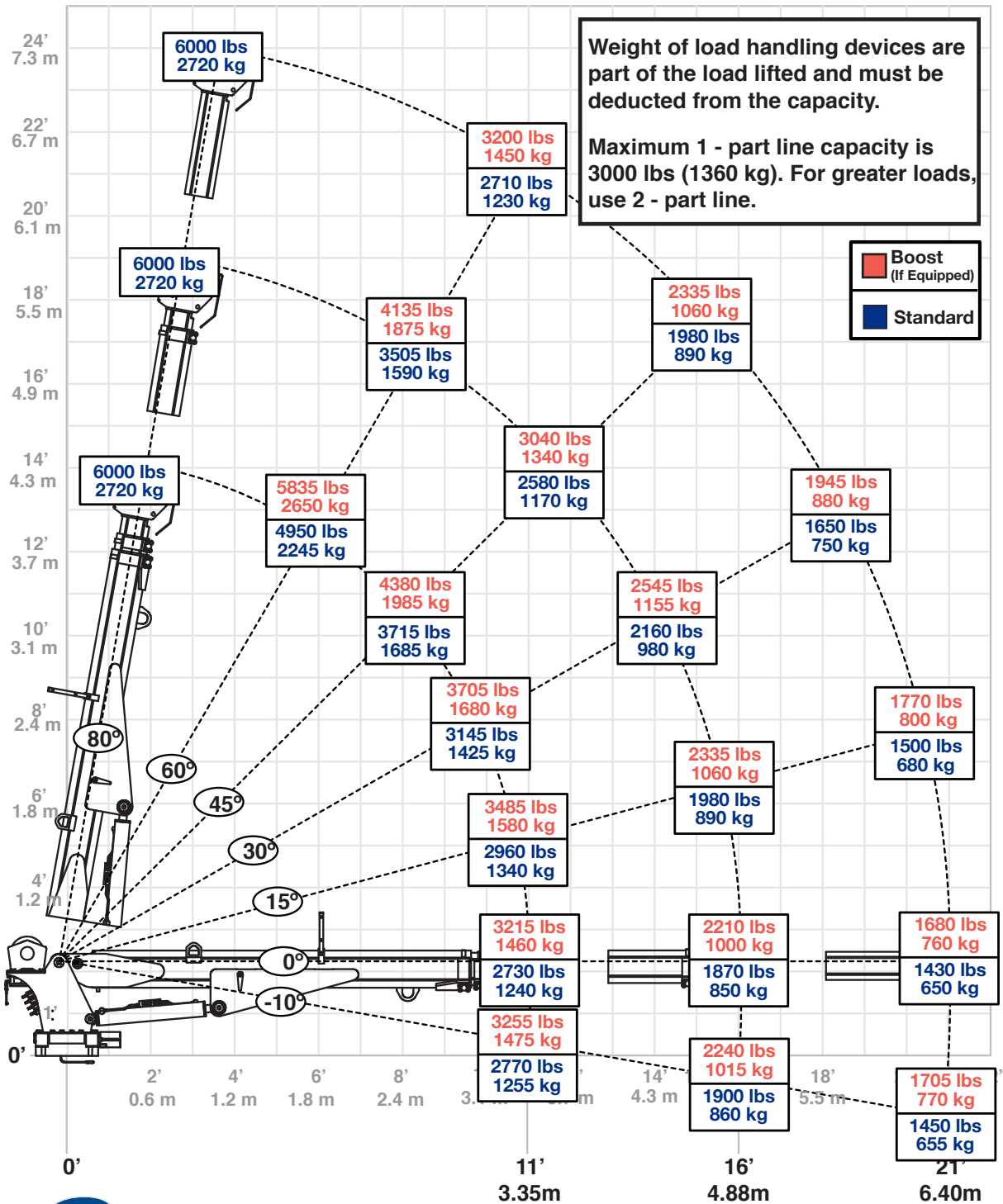

6521

PN 94740 - Rev A

Dimensional Drawing 1

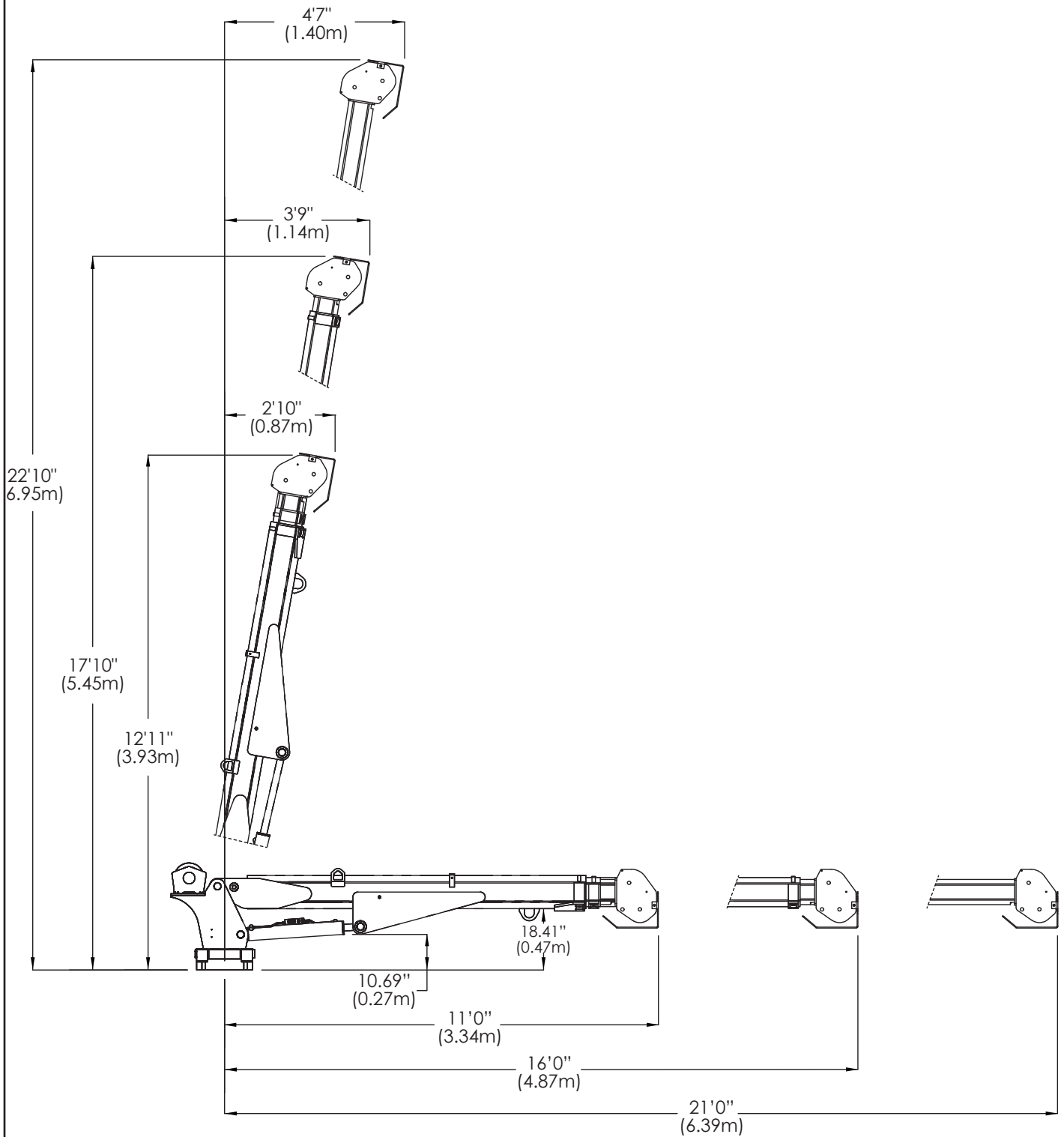

Dimensional Drawing 2

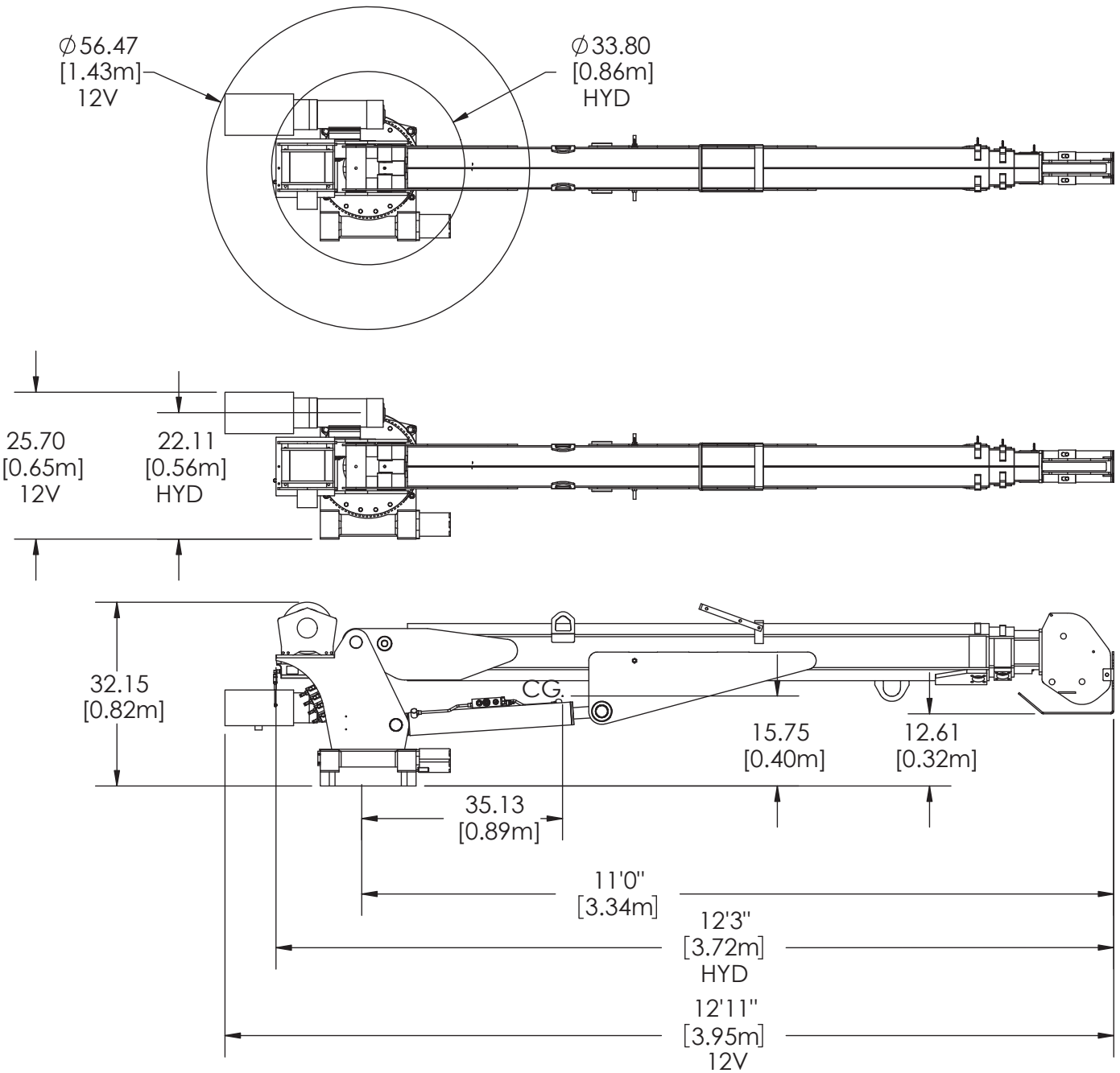

Chapter 2 - Installation

General Installation

This chapter is designed to serve as a general guide for the installation of a Stellar® 6521 Crane on a Stellar® Service Body. Each installation is considered unique so certain portions of this chapter may or may not apply to your direct application. If a question should arise during the installation process, please contact Stellar® Customer Service at (800) 321 3741.

This crane is designed for use with a Stellar® Service Body installed on a vehicle that meets the minimum chassis requirements of the crane. It is the installer's responsibility to assure that the crane is mounted on a platform that will support the maximum crane rating of this crane.

⚠ WARNING Do not install this crane on a body not capable of handling the loads imposed on it. Failure to do so may result in serious injury or death.

NOTICE When installing welder units to the service bodies, it is highly recommended that a surge protector is installed on the chassis batteries to protect the crane radio receiver, wiring and other electronic devices from an unexpected electrical spike or surge. Failure to do so could result in extensive damage to the service body and crane electrical circuit.

Installer Notice

According to Federal Law (49 cfr part 571), each final-stage manufacturer shall complete the vehicle in such a manner that it conforms to the standards in effect on the date of manufacture of the incomplete vehicle, the date of final completion, or a date between those two dates. This requirement shall, however, be superseded by any conflicting provisions of a standard that applies by its terms to vehicles manufactured in two or more stages.

Therefore, the installer of Stellar® Cranes and Bodies is considered one of the manufacturers of the vehicle. As such a manufacturer, the installer is responsible for compliance with all applicable federal and state regulations. They are required to certify that the vehicle is in compliance with the Federal Motor Vehicle Safety Standards and other regulations issued under the National Traffic and Motor Vehicle Safety Act.

Please reference the Code of Federal Regulations, title 49 - Transportation, Volume 5 (400-999), for further information, or visit <http://www.gpoaccess.gov/nara/index.html> for the full text of Code of Federal Regulations.

Torque Data Chart

When using the torque data in the chart, the following rules should be observed:

- Bolt manufacturer's particular specifications should be consulted when provided.
- Flat washers of equal strength must be used.
- All torque measurements are given in foot-pounds. To convert to inch-pounds, multiply by 12.
- Torque values specified are for bolts with residual oils or no special lubricants applied. If special lubricants of high stress ability, such as Never-Seez compound graphite and oil, molybdenum disulphite, colloidal copper or white lead are applied, multiply the torque values in the charts by the factor .90. The use of Loctite does not affect the torque values listed above.
- Torque values for socket-head capscrews are the same as for Grade 8 capscrews.
- Do not use these values if a different torque value or tightening procedure is given for a specific application. Torque values listed are for general use only. Check tightness of fasteners periodically.
- Shear bolts are designed to fail under predetermined loads. Always replace shear bolts with identical grade.
- Fasteners should be replaced with the same or higher grade. If higher grade fasteners are used, these should only be tightened to the strength of the original.
- Tighten plastic insert or crimped steel-type lock nuts to approximately 110 percent of the dry torque values shown in the chart below, applied to the nut, not to the bolt head. Tighten toothed or serrated-type lock nuts to the full torque value. *Note: "Lubricated" means coated with a lubricant such as engine oil, or fasteners with phosphate and oil coatings. "Dry" means plain or zinc plated without lubrication. Tighten lubricated bolts to approximately 80% of dry bolts.*

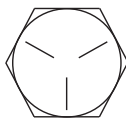
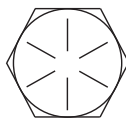
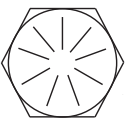
		GRADE 5		GRADE 8		GRADE 9
						
Size (DIA-TPI)	Bolt DIA (Inches)	Plain (Ft-Lb)	Plated (Ft-Lb)	Plain (Ft-Lb)	Plated (Ft-Lb)	Plated (Ft-Lb)
5/16-18	0.3125	17	13	25	18	22
3/8-16	0.3750	31	23	44	33	39
7/16-14	0.4375	49	37	70	52	63
1/2-13	0.5000	75	57	105	80	96
9/16-12	0.5625	110	82	155	115	139
5/8-11	0.6250	150	115	220	160	192
3/4-10	0.7500	265	200	375	280	340
7/8-9	0.8750	395	295	605	455	549
1-8	1.000	590	445	910	680	823
1 1/8-7	1.1250	795	595	1290	965	1167
1 1/4-7	1.2500	1120	840	1815	1360	1646
1 3/8-6	1.3750	1470	1100	2380	1780	2158
1 1/2-6	1.500	1950	1460	3160	2370	2865

Installation Overview

1. Determine that the mounting location for the 6521 crane is at least 18" x 20" (45.7 x 50.8 cm).
2. Use the detail below to drill 1.06" diameter holes into the mounting plate. Run tap on the threads of the base to be sure they are clean.
3. Use a crane or lifting device capable of lifting the weight of the Stellar® crane. The Stellar 6521 weighs approximately 1400 lbs (635 kg). **Note: cranes are shipped with rotation positioned at 200 degrees of 400 degree system.** This will allow for easy installation of the crane and permanent connection of all hydraulic and electrical components prior to repositioning into the crane saddle.
4. Connect straps or chain from the lifting device to the lifting rings on the 6521.
5. Use four (4) 1" x 3" #8 bolts and four (4) #8 flat washers.
6. Install a washer on each bolt.
7. Apply Loctite Thread locker #277 to the bolts.
8. Using the lifting device, lower the 6521 just above the crane compartment and start the bolts. Have someone assist in leveling the crane. **Note: the rotation motor should be to the door side of crane compartment and the boom should be extended back over the rear bumper.**
9. Secure the crane using the mounting hardware provided. **Note: longer or shorter cap screws may be required – recommended thread engagement into crane base is 1.75" – use grade 8, zinc plated cap screws only.**
10. Torque the cap screws to 680 ft-lbs.
11. Remove supporting crane.
12. Hook-up hydraulics and electrical.

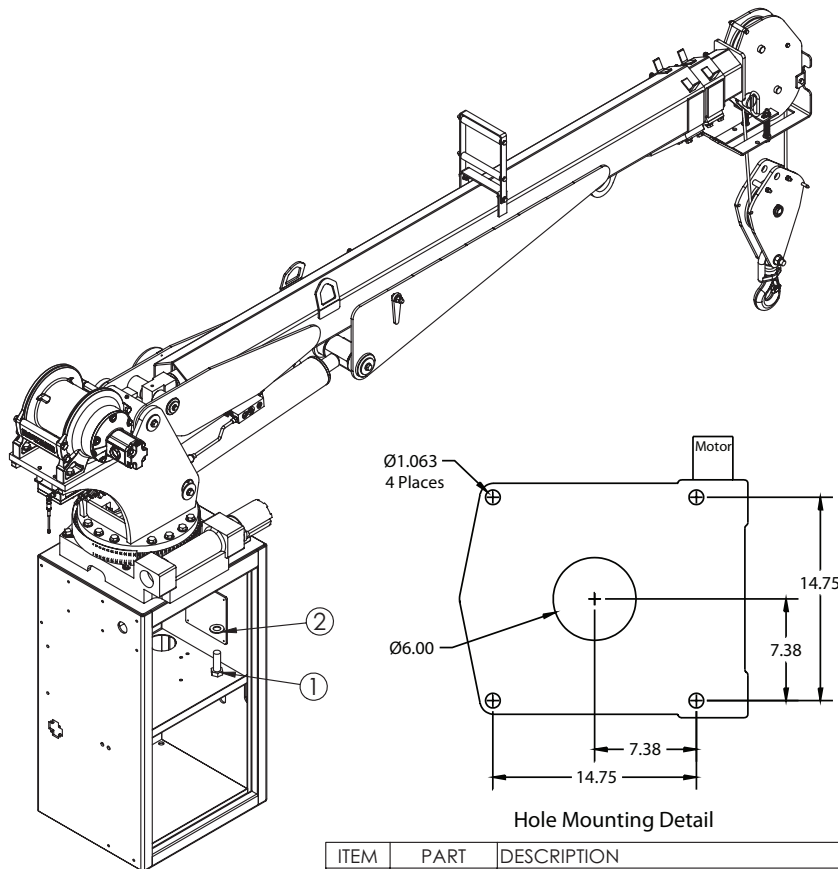

Hole Mounting Detail

ITEM	PART	DESCRIPTION	QTY.
1	5199	CAP SCR 1.00X8X3.00 HHGR8 ZY	4
2	6538	WASHER 1.00 SAE FLAT YELLOW GR8	4

Control Kit (Cradle CDT Non-Boost) - PN 94716

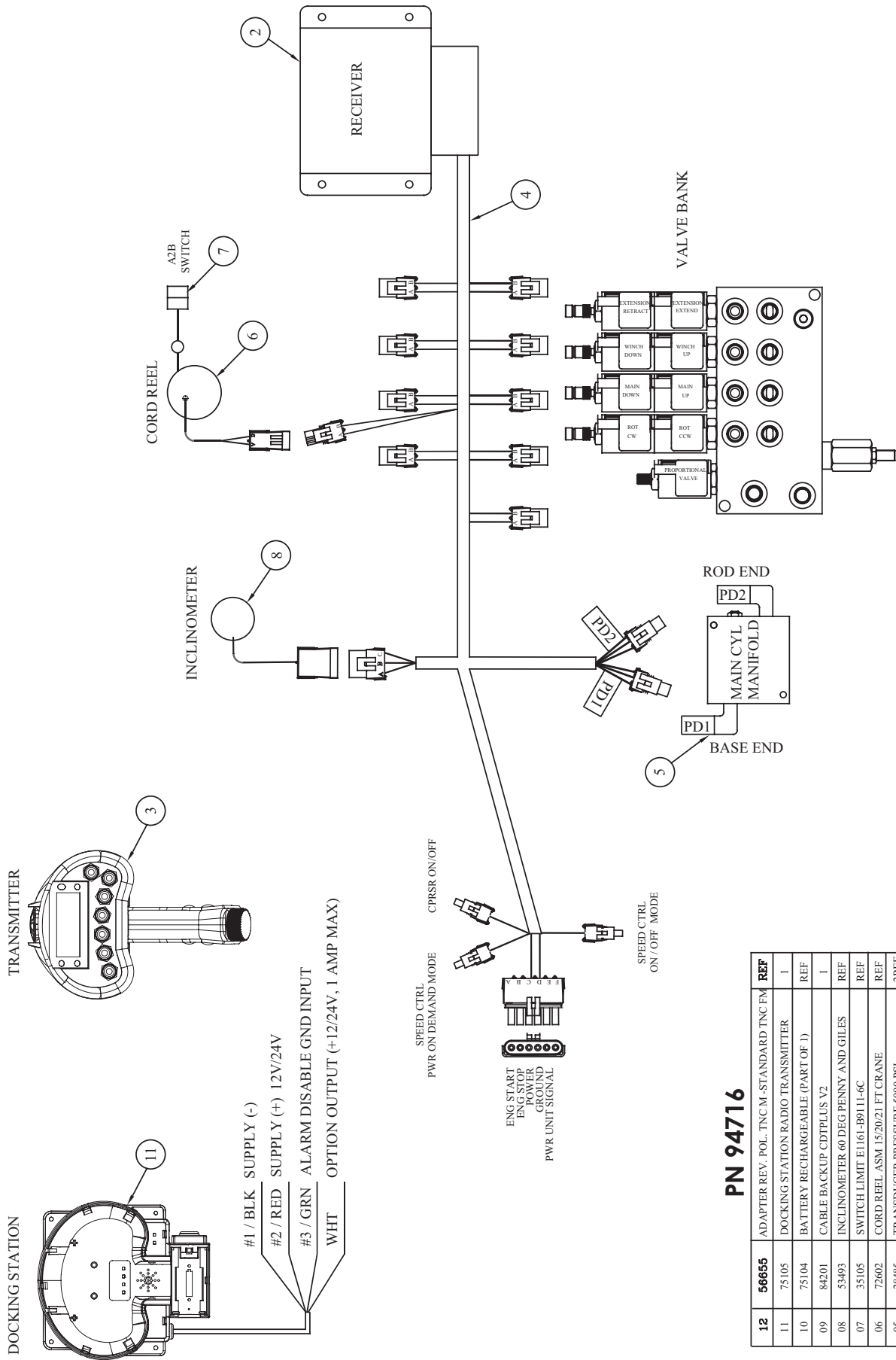

PN 94716

ITEM	56855	REF	DESCRIPTION	QTY
12	ADAPTER REV. POL. TNC M-STANDARD TNC FM	REF		
11	75105	1	ADAPTER REV. POL. TNC M-STANDARD TNC FM	
10	75104	REF	DOCKING STATION RADIO TRANSMITTER	
09	84201	1	BATTERY RECHARGEABLE (PART OF 1)	
08	53493	REF	CABLE BACKUP CDTPLUS V2	
07	35105	REF	INCLINOMETER 60 DEG PENNY AND GILES	
06	72602	REF	SWITCH LIMIT E1161-489111-6C	
05	28485	2REF	CORD REEL ASM 15/20/21 FT CRANE	
04	46307	1	TRANSDUCER PRESSURE 5000 PSI	
03	84200	REF	WIRE HARNESS 12621/12628 LMI	
02	61067	REF	TRANSMITTER - RADIO (PART OF 1)	
01	68168	1	RECEIVER - RADIO (PART OF 1)	
			RADIO CONTROLLER ASSEMBLY	
			PART No.	
			DESCRIPTION	
			QTY	

Control Kit (Cradle 12V CDT Non-Boost) - PN 68167

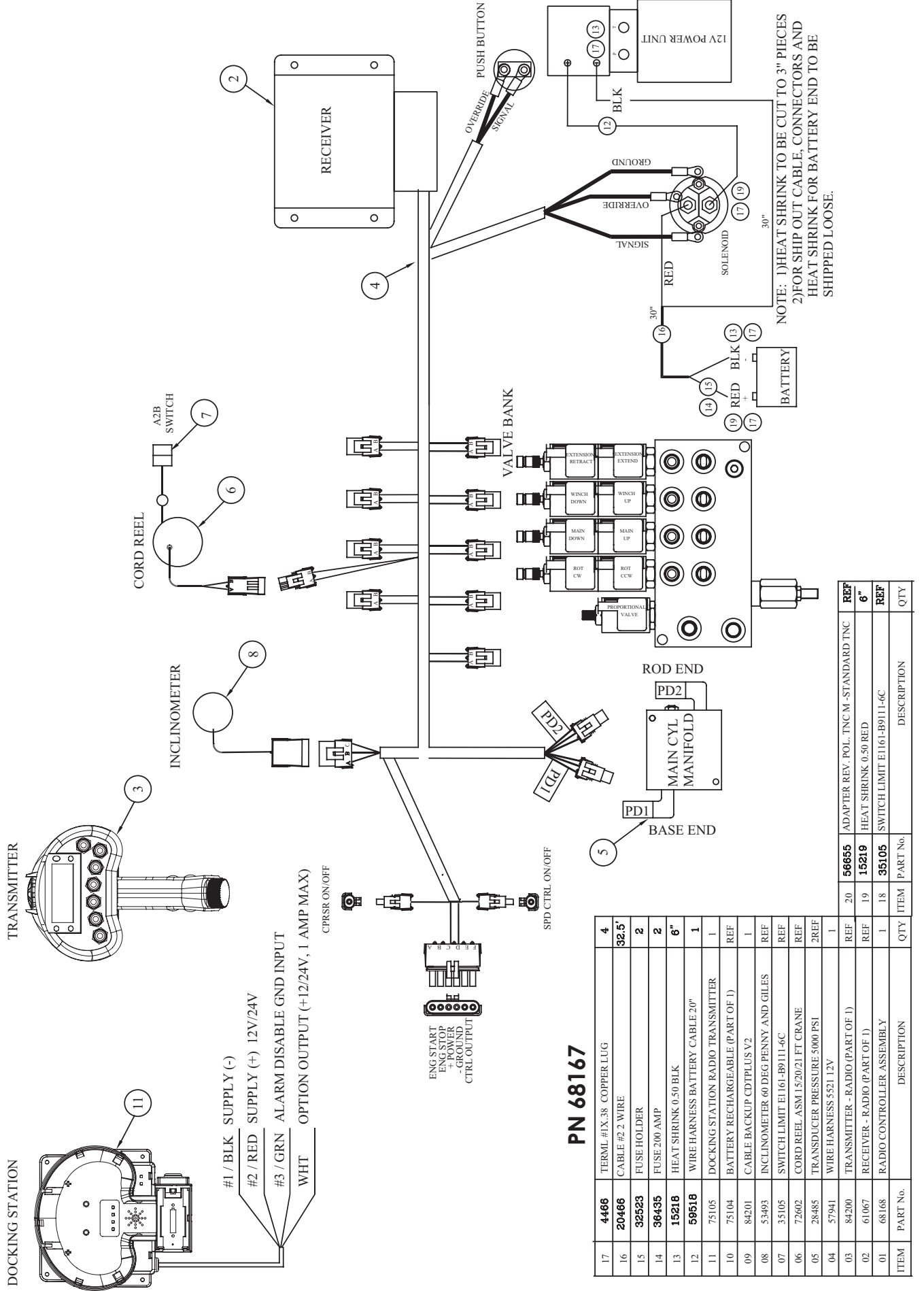

PN 68167

ITEM	PART No.	DESCRIPTION	QTY	ITEM	PART No.	DESCRIPTION	QTY
17	4466	TERML #1X.38 COPPER LUG	4	20	56655	ADAPTER REV. POL. TNC M - STANDARD TNC	REF
16	20466	CABLE #2 WIRE	32.5'	19	15219	HEAT SHRINK 0.50 RED	6"
15	32523	FUSE HOLDER	2	18	35105	SWITCH LIMIT E1161-B9111-6C	REF
14	36435	FUSE 200 AMP	2				
13	15218	HEAT SHRINK 0.50 BLK	6"				
12	59518	WIRE HARNESS BATTERY CABLE 20"	1				
11	75105	DOCKING STATION RADIO TRANSMITTER	1				
10	75104	BATTERY RECHARGEABLE (PART OF 1)	REF				
09	84201	CABLE BACKUP CDTPLUS V2	1				
08	53493	INCLINOMETER 60 DEG PENNY AND GILES	REF				
07	35105	SWITCH LIMIT E1161-B9111-6C	REF				
06	72602	CORD REEL ASM 15/20/21 FT CRANE	REF				
05	28485	TRANSDUCER PRESSURE 5000 PSI	2REF				
04	57941	WIRE HARNESS 5521 12V	1				
03	84200	TRANSMITTER - RADIO (PART OF 1)	REF				
02	61067	RECEIVER - RADIO (PART OF 1)	REF				
01	68168	RADIO CONTROLLER ASSEMBLY	1				

Wiring Diagram (Electrical Version)

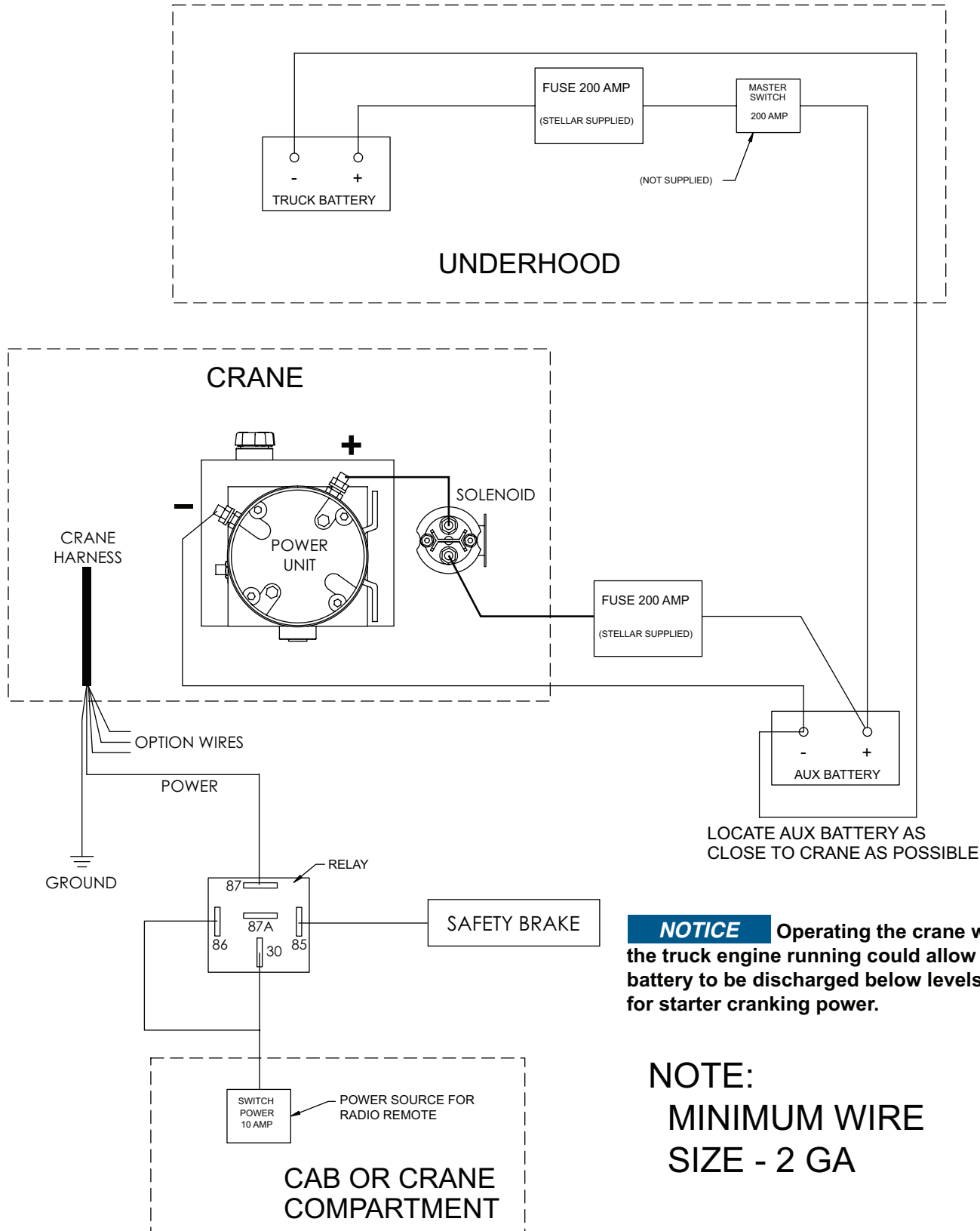

NOTICE Operating the crane without the truck engine running could allow the truck battery to be discharged below levels required for starter cranking power.

NOTE:
MINIMUM WIRE
SIZE - 2 GA

Hydraulic Kit (CDT) - PN 72837

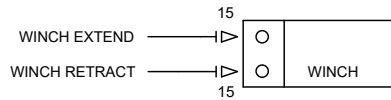
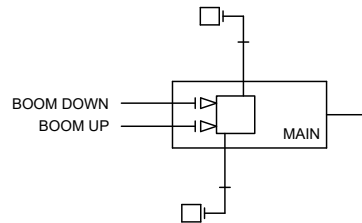
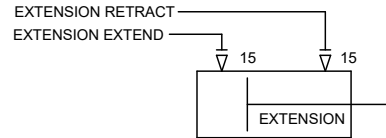
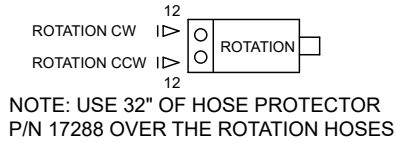
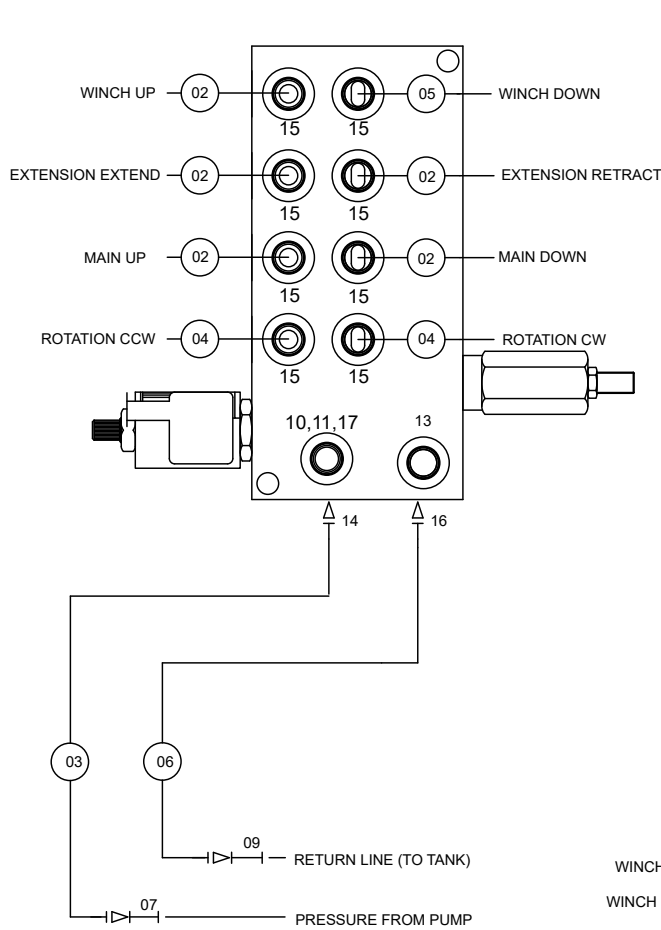

NOTE: USE 12" OF HOSE PROTECTOR P/N 17288 OVER THE 2 WINCH HOSES

ITEM	PART	DESCRIPTION	QTY
01	72838	HOSE KIT 5521 V2 (INCL:2-6)	1
02	13028	HOSE-HYD .38 X 17	5REF
03	45439	HOSE-HYD .38 X 9	1REF
04	13030	HOSE-HYD .38 X 39	2REF
05	59137	HOSE-HYD .38 X 19	1REF
06	45438	HOSE-HYD .50 X 8	1REF
07	12171	FTG 6-6 MFS-MFS SWIVEL STRAIGHT	1
08	17288	HOSE PROTECTOR 1.00 AS-B-27	12"
09	12172	FTG 8-8 MFS-MFS SWIVEL STRAIGHT	1
10	15111	FTG 6-4 MORB-FORB STRAIGHT REDUCER	1
11	3861	FTG 6-6 MAORB-FORB 90	1
12	D1302	FTG 6-10 MFS-MAORB 90	2
13	C4961	FTG 6 MORB PLUG HOLLOW HEX	1
14	D1193	FTG 6-6 MFS-MAORB 45	1
15	0279	FTG 6-6 MFS-MORB STRAIGHT	12
16	C1175	FTG 8-8 MFS-MAORB 45	1
17	39780	GAUGE OIL LF 2.5" 0-5000 CBM	1

NOTE: HARDWARE KIT: 115668

Hydraulic Kit (12V CDT) - PN 72839

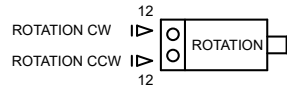
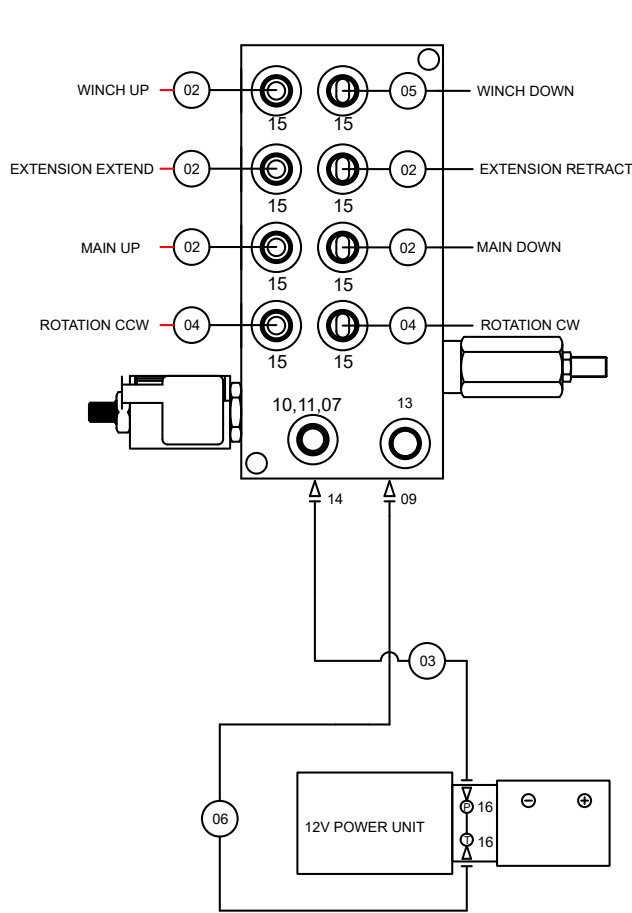

NOTE: USE 32" OF HOSE PROTECTOR P/N 17288 OVER THE ROTATION HOSES

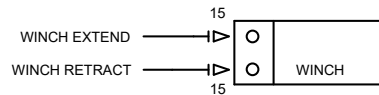
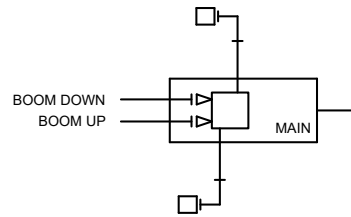
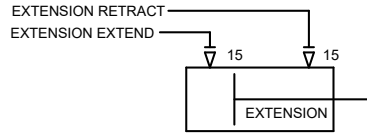

NOTE: USE 12" OF HOSE PROTECTOR P/N 17288 OVER THE 2 WINCH HOSES

ITEM	PART	DESCRIPTION	QTY
01	72935	HOSE KIT 5521 12V V2 (INCL:2-6)	1
02	13028	HOSE-HYD .38 X 17	5REF
03	59519	HOSE-HYD .25 X 26	1REF
04	13030	HOSE-HYD .38 X 39	2REF
05	59137	HOSE-HYD .38 X 19	1REF
06	59520	HOSE-HYD .38 X 29	1REF
07	39780	GAUGE OIL LF 2.5 0-5000 CBM SAE	1
08	17288	HOSE PROTECTOR 1.00 AS-B-27	12"
09	C1175	FTG 8-8 MFS-MAORB 45	1
10	15111	FTG 6-4 MORB-FORB STRAIGHT REDUCER	1
11	3861	FTG 6-6 MAORB-FORB 90	1
12	D1302	FTG 6-10 MFS-MAORB 90	2
13	C4961	FTG 6 MORB PLUG HOLLOW HEX	1
14	D1193	FTG 6-6 MFS-MAORB 45	1
15	0279	FTG 6-6 MFS-MORB STRAIGHT	12
16	C0338	FTG 6-6 MFS-MAORB 90	2

NOTE:
HARDWARE KIT: 115669

Valve Bank - PN 44530

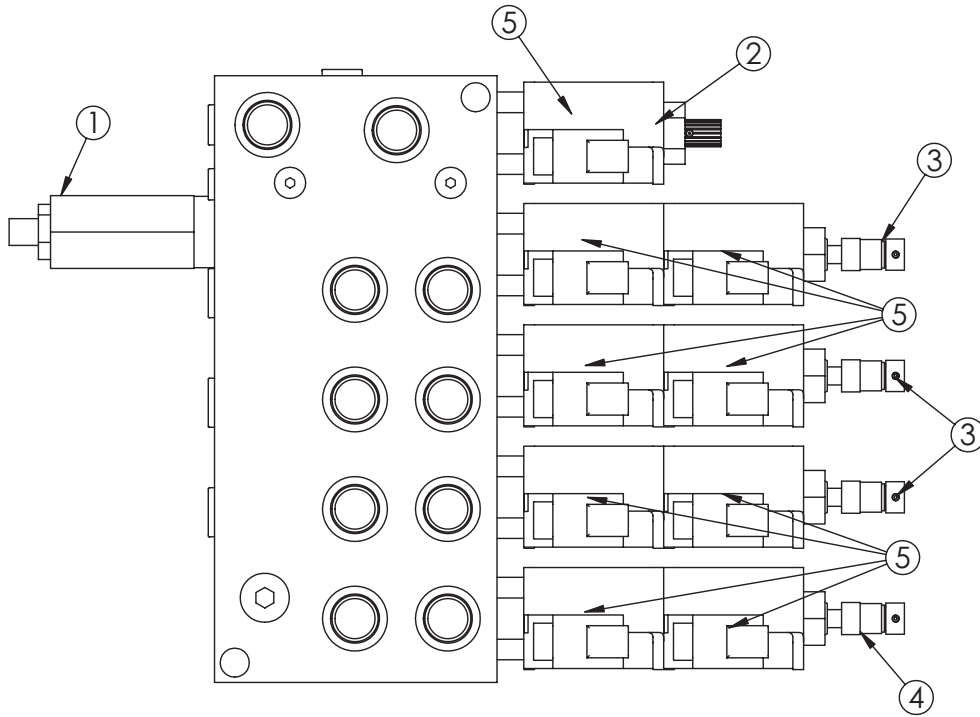

HYDRAULIC SCHEMATIC

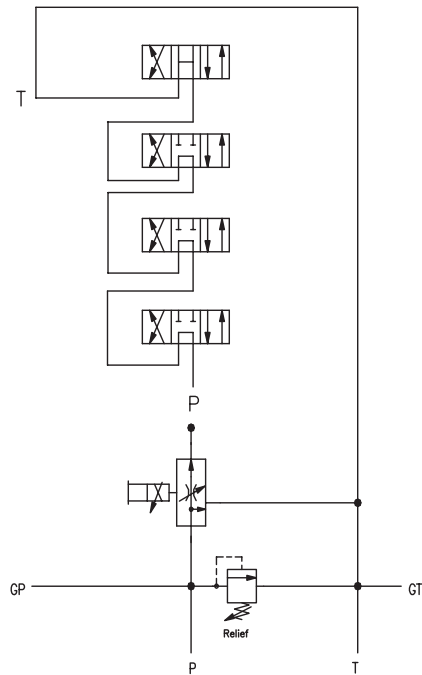
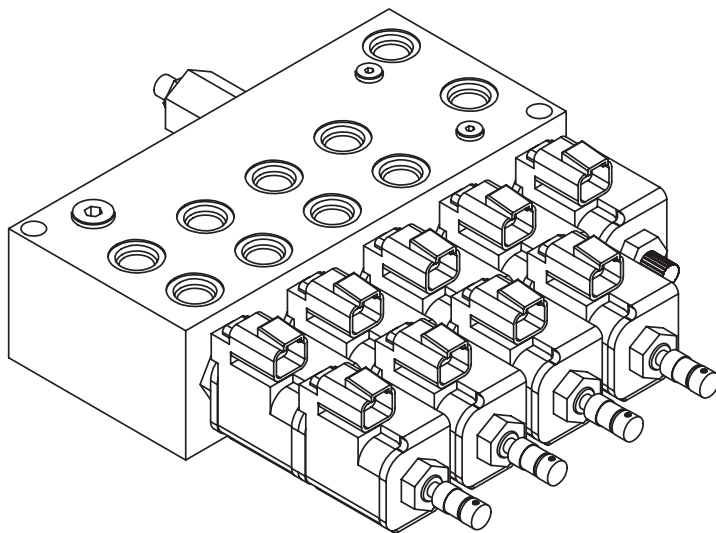

PN 44530

ITEM	PART No.	DESCRIPTION	QTY.	TORQUE
1	25367	RELIEF VALVE 24685/24690	1	37 FT LBS
	25368	SEAL KIT 25367		
2	24960	VALVE FLW CTRL PRP/JP04C3150N 0-8	1	20-22 FT LBS
	25369	SEAL KIT 24960/25381		
3	25371	VALVE SOLND 3 POS 4 WAY TAND G04571	3	25 FT LBS
4	25372	VALVE SOLND 3 POS 4 WAY OPEN G04591	1	25 FT LBS
	25373	SEAL KIT 25371/25372		
5	44532	COIL 12VDC DUETSCH CAP012H	9	3 FT LBS

NOTE: PN's 24960 & 25371 DO NOT INCLUDE COIL PN 44532

Valve Bank (Alternate)- PN 125254

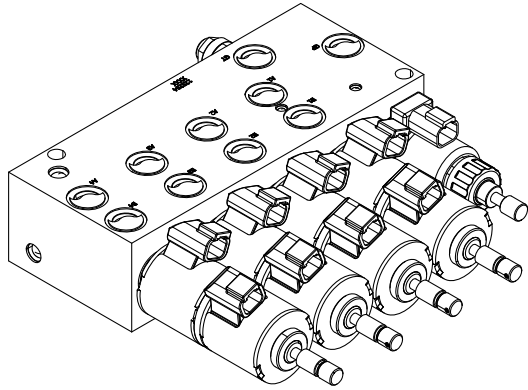

HYDRAULIC SCHEMATIC

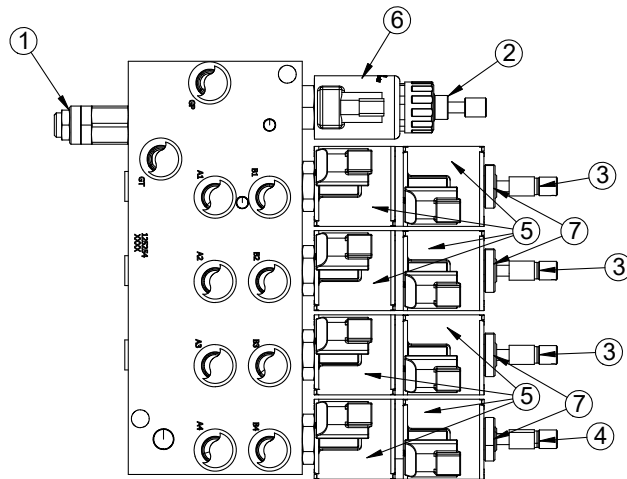
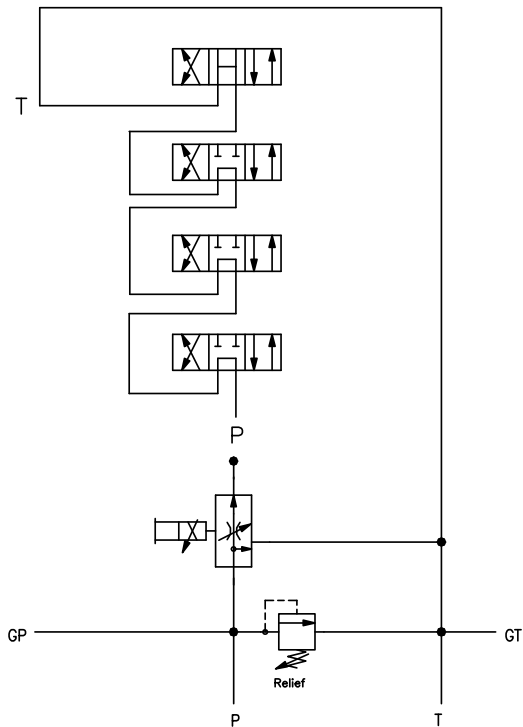

Valve Bank (Alternate) - PN 125254 Parts List

PN 125254				
ITEM	PART	DESCRIPTION	QTY	TORQUE
1	125946	VALVE RELIEF 125254	1	37 FT-LB
	126271	SEAL KIT 125946		
2	125255	VALVE FLW CTRL PRP 0-8 GPM DEL	1	20-22 FT-B
	126270	SEAL KIT 125255		
3	125256	VALVE SOLND 3 POS 4 WAY 8GPM TANDEM DEL	3	25 FT-LB
4	125257	VALVE SOLND 3 POS 4 WAY 8GPM OPEN DEL	1	25 FT-LB
	126269	SEAL KIT 125256/125257		
5	125947	COIL 12VDC DEUTSCH DEL	8	3 FT-LB
6	125948	COIL 12VDC DEUTSCH PROP DEL	1	3 FT-LB
7	134698	NUT COIL RETAINING DELTROL SIZE 10	4	3 FT-LB

Hydraulic Installation

1. After mounting, locate the pressure and return lines. Note: Pressure line is 3/8" hose; Return line is 1/2" hose. Hoses are terminated using swivel fittings.
2. Install hydraulic lines per diagram below. Note: Stabilizer valve supplies oil to crane using the Power Beyond feature.
3. Install hydraulic reservoir with return filter. Attach pump pressure line to valve, return link to tank.
4. Fill system with hydraulic oil (See Stellar® Lubrication Recommendations for fluid details).

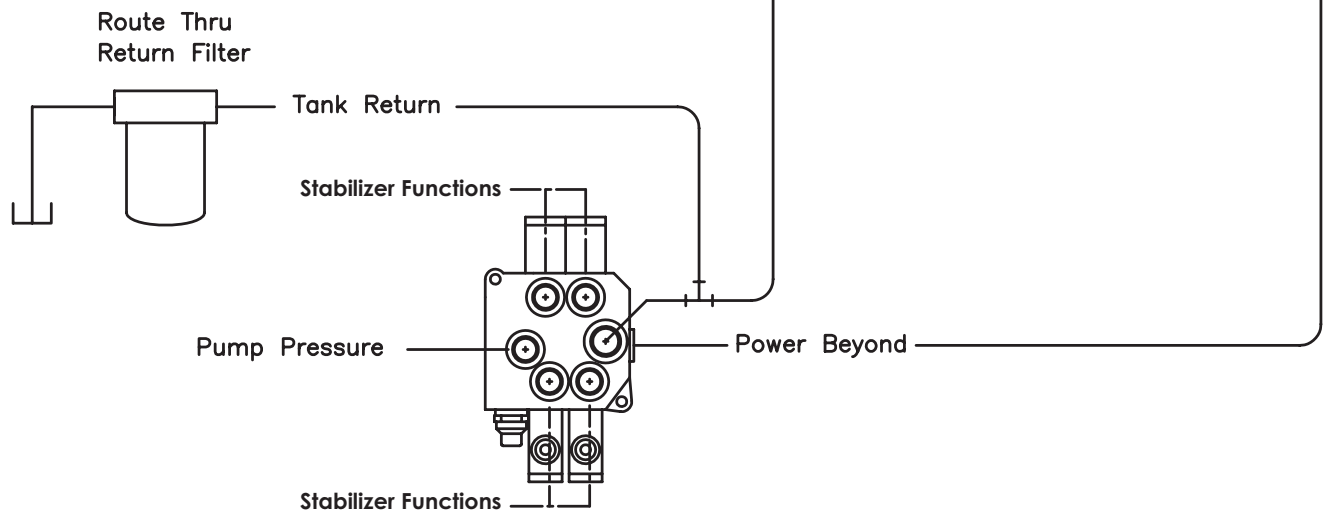
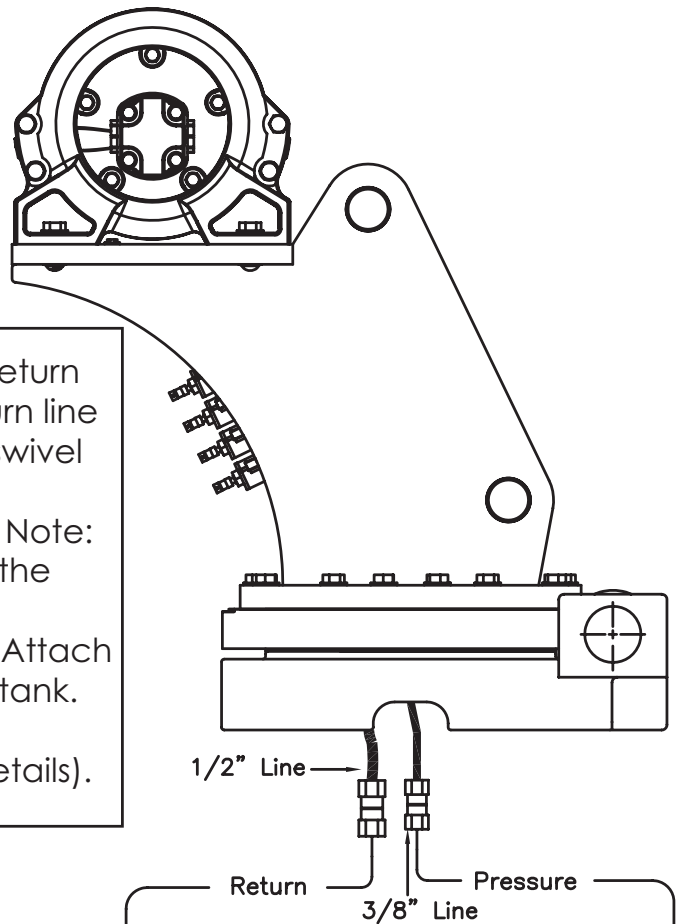

Typical Stabilizer Valve
with Power Beyond Capabilities

Hydraulic System

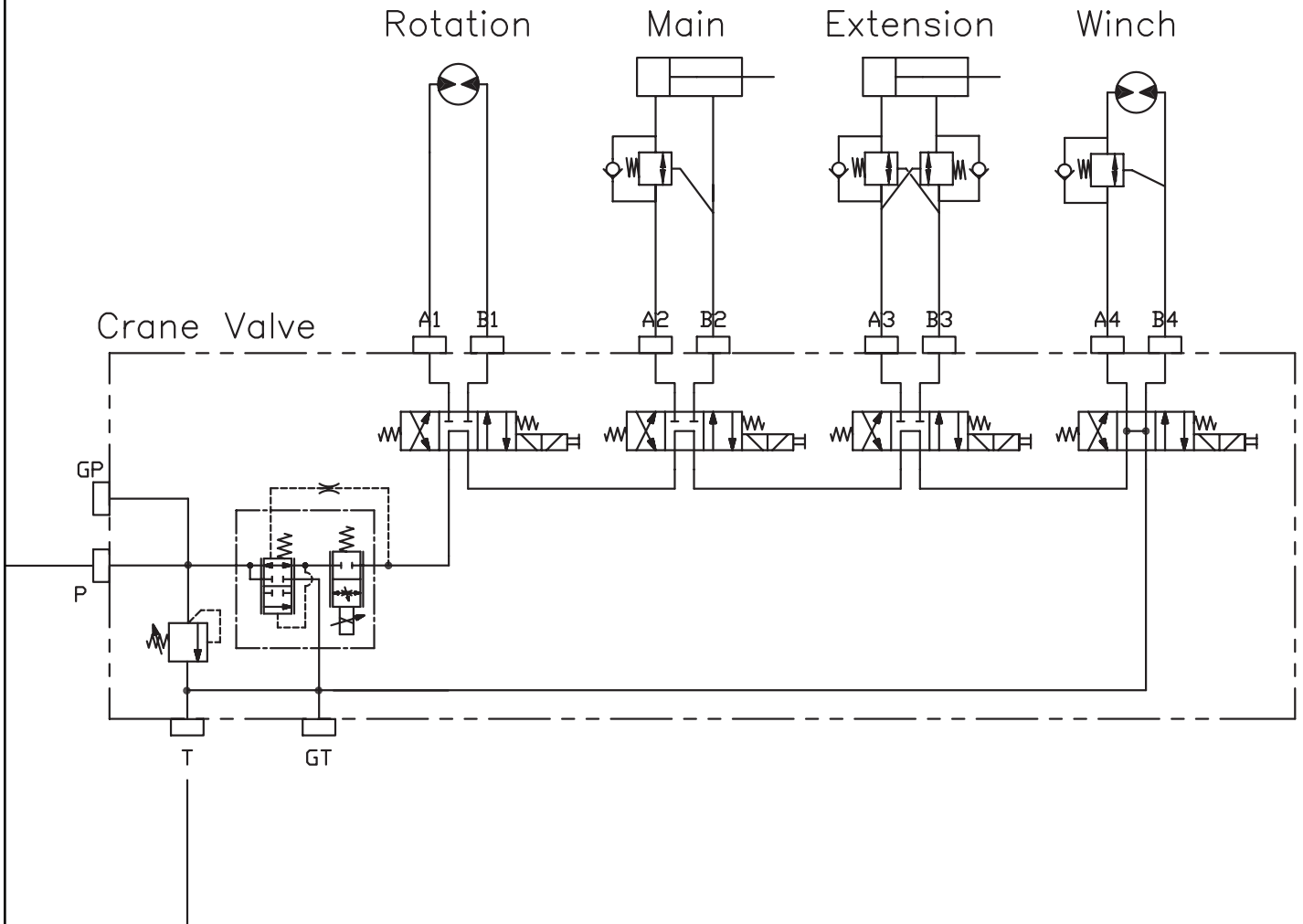

Face Seal/O-Ring Size Chart

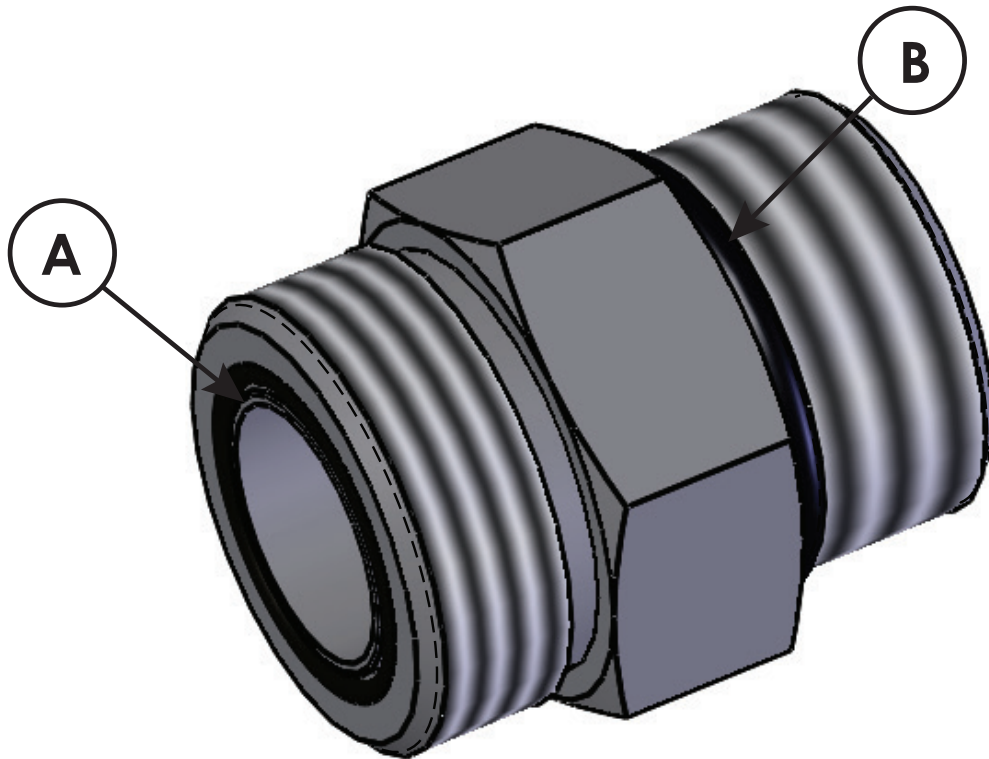

Hose Size	Fitting Size	Face Seal (A) Stellar® PN	O-ring Boss (B) Stellar® PN
1/4"	#4	C2027	D1245
3/8"	#6	C2028	D1246
1/2"	#8	C2029	D1247
5/8"	#10	32223	D1248
3/4"	#12	D1244	D1249
1"	#16		D1250

Stability Procedure

Definition of Stability for the Stellar Telescopic Crane Products:

A truck is stable until the load cannot be lifted off the ground with the winch, without tipping over the truck. Every Stellar crane installed must be tested for stability to determine the actual load capacity of the final truck package. The actual test data must be recorded and supplied with the truck at the time of in-service and should be kept with the truck at all times. The following procedure will test the truck package for stability and will provide a stability capacity chart. The load limit information shown on the stability capacity chart is formulated on 85% tipping.

Set Up:

1. Locate the truck on a test course in position for loading and engage travel brakes.
2. Set stabilizers so that they make contact with firm, level footing.
3. Operate the crane under partial load to assure operator proficiency and proper machine function.
4. Put the radio into Stability Test Mode:
 - A. Push the middle four switches up and hold until "STB" appears on the screen (approximately 5 seconds.)
 - B. At this point, the crane will have enough capacity to handle the weight for the stability test.
 - C. The radio will timeout of stability mode after 30 minutes or when the E-Stop button is pushed.



Note: The radio can only be put into stability mode five times. After that, the radio would have to be returned to Stellar to be reprogrammed to allow additional stability testing. All other radio functions will work properly even if stability mode is not available.

Stability Procedure Continued...

6521 Stability Data

Max Horizontal Reach: 252" (From the center of rotation to boom tip)

Boost Stability Test Weight: 1980 lbs.

Non-Boost Stability Test Weight: 1680 lbs.

Test Procedure

1. Rotate the crane into Zone 1 position.
2. With the crane fully retracted and the boom horizontal, winch the test weight off the ground.
Note: Keep weight within six inches of the ground at all times.
3. Extend the boom outward until full extension has been reached or until the truck becomes unstable (Again, use the winch to keep the weight within six inches of the ground.)
4. If the boom goes full extension without becoming unstable, the crane is termed stable for this zone and 100% can be written in the Zone 1 data box.

5. If the truck becomes unstable prior to going full extension, retract the boom until the truck becomes stable and measure the horizontal reach in this position (center of rotation to boom tip). This is the stable horizontal reach for this zone. Stable horizontal reach divided by Maximum horizontal reach multiplied by 100 equals the percentage of rated capacity for this zone. Use the following formula to determine the percentage of rated capacity:

$$\frac{\text{Stable Horizontal Reach}}{\text{Max Horizontal Reach}} \times 100 = \text{Percentage of Rated Capacity}$$

6. Record this number in the data box for Zone 1. This is the revised capacity due to stability for this zone.
7. Repeat this procedure for each zone until the worksheet is completed.
8. This is the revised capacity based on stability of this package.

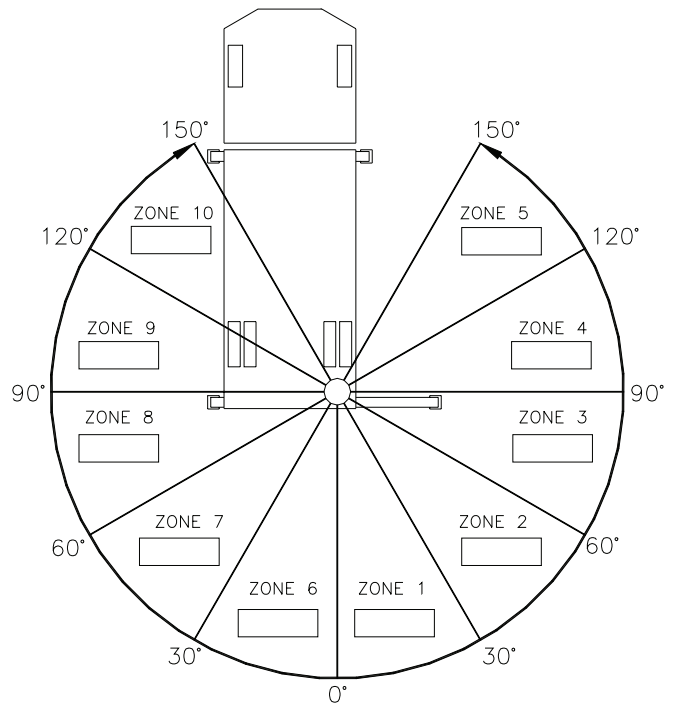

Crane Load Level Indicator

Stellar® Cranes are shipped with a load level indicator that is used to determine if the truck is level (side to side) before using the crane to pick/move a load. This level should be installed in the isolated crane compartment of the body. If level indicator is missing or damaged, please contact Stellar Customer Support for a replacement.



PN 76483

Decal Placement - PN 68169

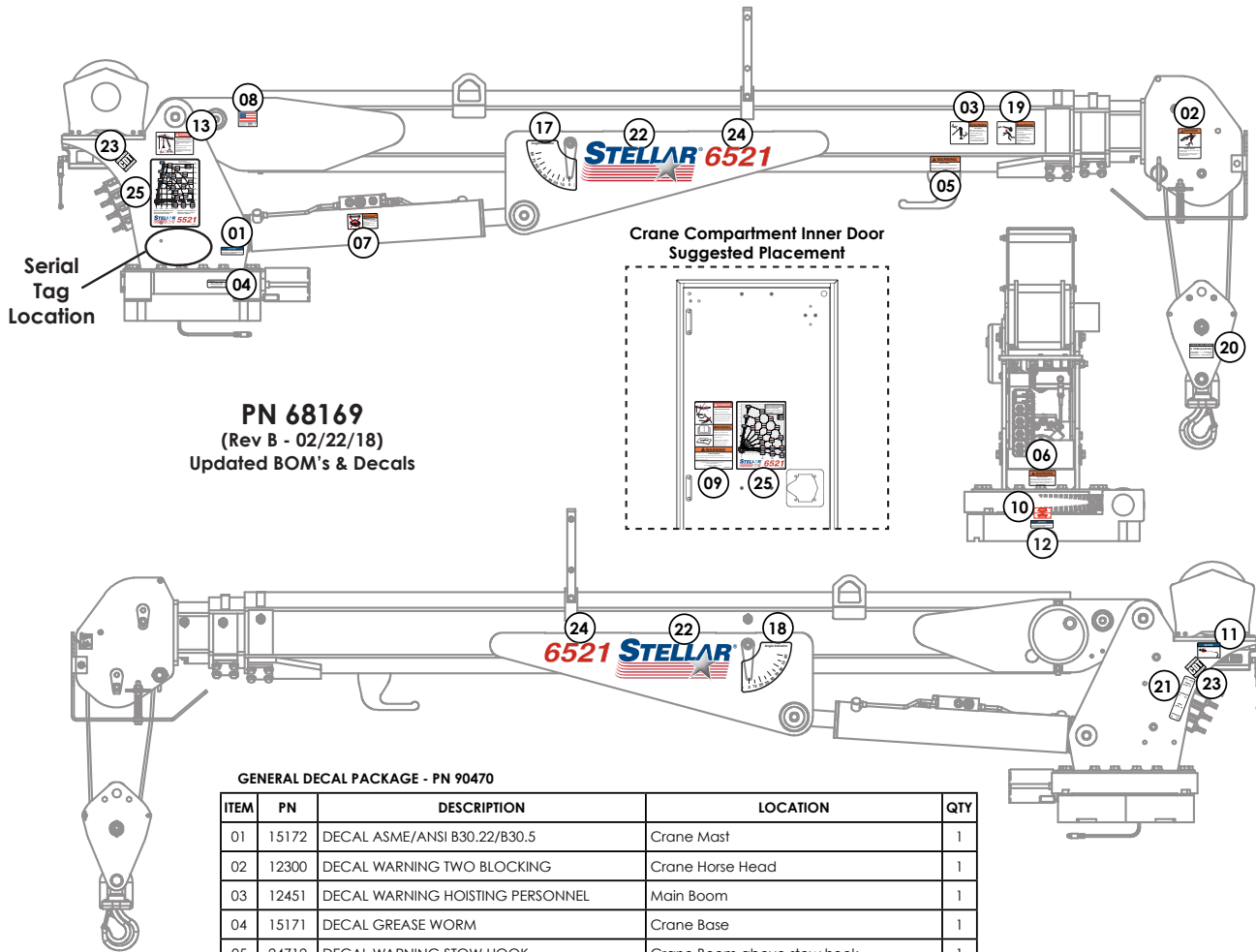

PN 68169
(Rev B - 02/22/18)
Updated BOM's & Decals

GENERAL DECAL PACKAGE - PN 90470

ITEM	PN	DESCRIPTION	LOCATION	QTY
01	15172	DECAL ASME/ANSI B30.22/B30.5	Crane Mast	1
02	12300	DECAL WARNING TWO BLOCKING	Crane Horse Head	1
03	12451	DECAL WARNING HOISTING PERSONNEL	Main Boom	1
04	15171	DECAL GREASE WORM	Crane Base	1
05	24712	DECAL WARNING STOW HOOK	Crane Boom above stow hook	1
06	25159	DECAL WARNING MANUAL OVERRIDES	Under Valve Bank	1
07	28256	DECAL WARNING OVERLOAD DEVICE	Main Cylinder	1
08	35234	DECAL STELLAR MADE IN THE USA	Main Boom	1
09	93936	DECAL SAFETY & SERVICE MECH BODY DOOR	Crane Compartment	1
10	4188	DECAL ROTATION ALIGNMENT	Crane Base	1
11	73929	DECAL PRESSURE WASH	Crane Mast	1
12	9188	DECAL ROTATE/GREASE	Crane Base	1
13	C1179	DECAL DANGER ELECTROCUTION SMALL	Crane Mast	1
14*	C4545	DECAL DANGER ELECTROCUTION LARGE	Four corners of the body/chassis	4
15*	C5910	DECAL STELLAR 4x9.5	Suggested: Rear body/tailgate	1
16*	C5911	DECAL STELLAR 2x4.5	Suggested: Side corners of body	3
17	D1196	DECAL ANGLE INDICATOR CS	Main Boom	1
18	D1197	DECAL ANGLE INDICATOR SS	Main Boom	1

6521 DECAL PACKAGE - PN 94715

ITEM	PN	DESCRIPTION	LOCATION	QTY
19	12452	DECAL WARNING MANUAL EXT	Main Boom	1
20	116440	DECAL SNATCH BLOCK 5 TON	Snatch Block	1
21	41068	DECAL VB CONTROL MECH CRANE	On side of Crane Mast	1
22	52681	DECAL STELLAR LOGO 6.5 X 18	Main Boom (Both Sides)	2
23	54588	DECAL CDT 2.00 x 2.00	Crane Mast (Both Sides)	2
24	68170	DECAL IDENTIFICATION 6521	Main Boom (Both Sides)	2
25	94740	DECAL CAPACITY 6521	Main Boom and Crane Compartment	2
26*	C4795	DECAL WARNING STABILIZERS	Stabilizers	2

*Not Shown

This page intentionally left blank.

Chapter 3 - Assembly Drawings

Base Assembly - PN 50364

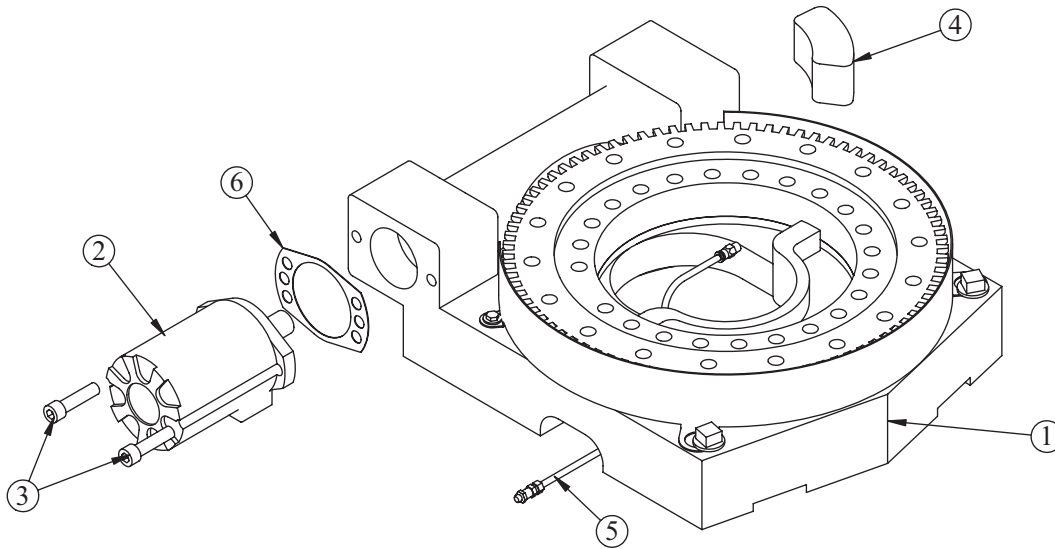

GASKET SHOWN AS REFERENCE

PN 50364

ITEM	PART No.	DESCRIPTION	QTY.
1	47869	BEARING SWING DRIVE CAST 6620 GEARTEK	1
2	C6069	MOTOR HYD ROSS MK080613AAAB	1
3	53495	CAP SCR 0.50-13X2.00 SH	2
4	11542	STOP 6620 400 SLIDE	1
5	104018	HARDWARE KIT BASE ASM 30IN GREASE LINE	1
6	21151	GASKET MOTOR 008-10056-1	1

NOTE: ITEM 1 INCLUDES GUARD & GUARD FASTENERS

Gear Bearing - PN 47869

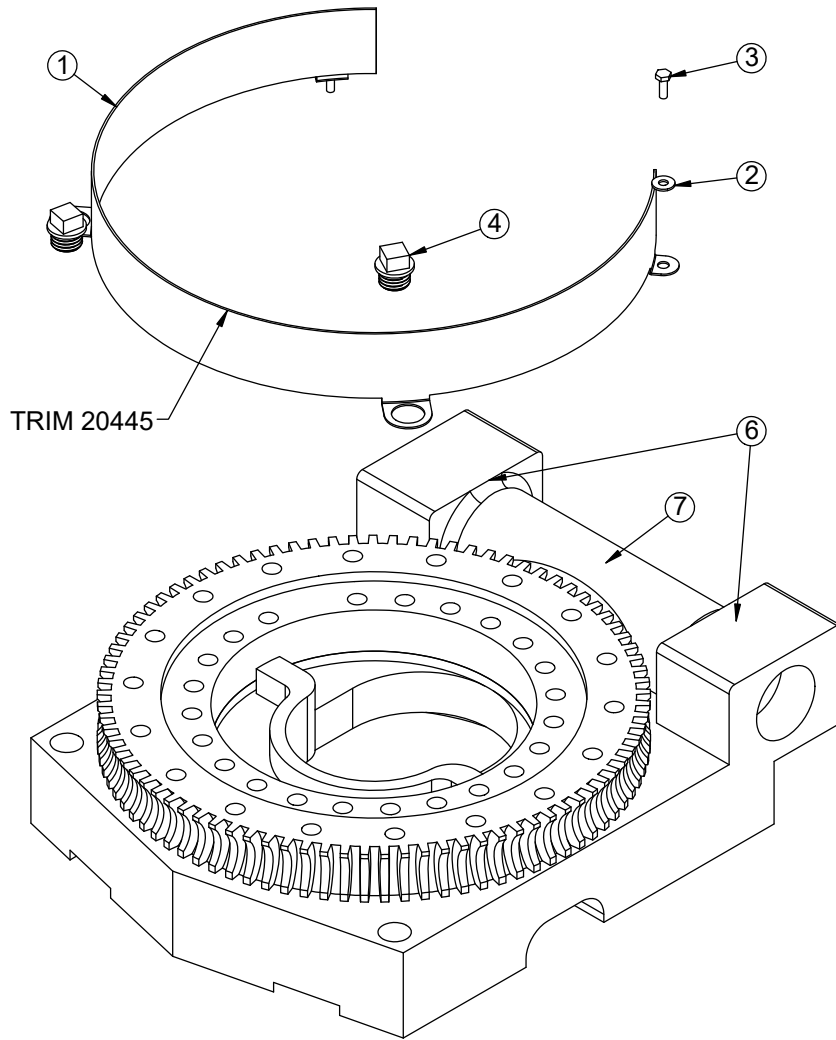

PN 47869

ITEM	PART	DESCRIPTION	QTY
1	44551PC	Default	1
2	0340	WASHER 0.25 FLAT	2
3	0479	CAP SCR 0.25-20X0.75 HHGR5	2
4	13959	CAP SCR 1.00-8 X .63 PLASTIC	2
5	20445	TRIM EDGE 0.06X0.56 AL 0.63 BULB	42"
ITEM	PART	DESCRIPTION	QTY
6	55829	BEARING AND SEAL KIT 66/76 PERFECTION CAST	1
7	55827	WORM PERFECTION 66/76	1
ITEM	PART	DESCRIPTION	QTY
6	25896	BEARING AND SEAL KIT 10620 GP CAST	1
7	25895	WORM 10620 GP	1

Mast Assembly - PN 72819

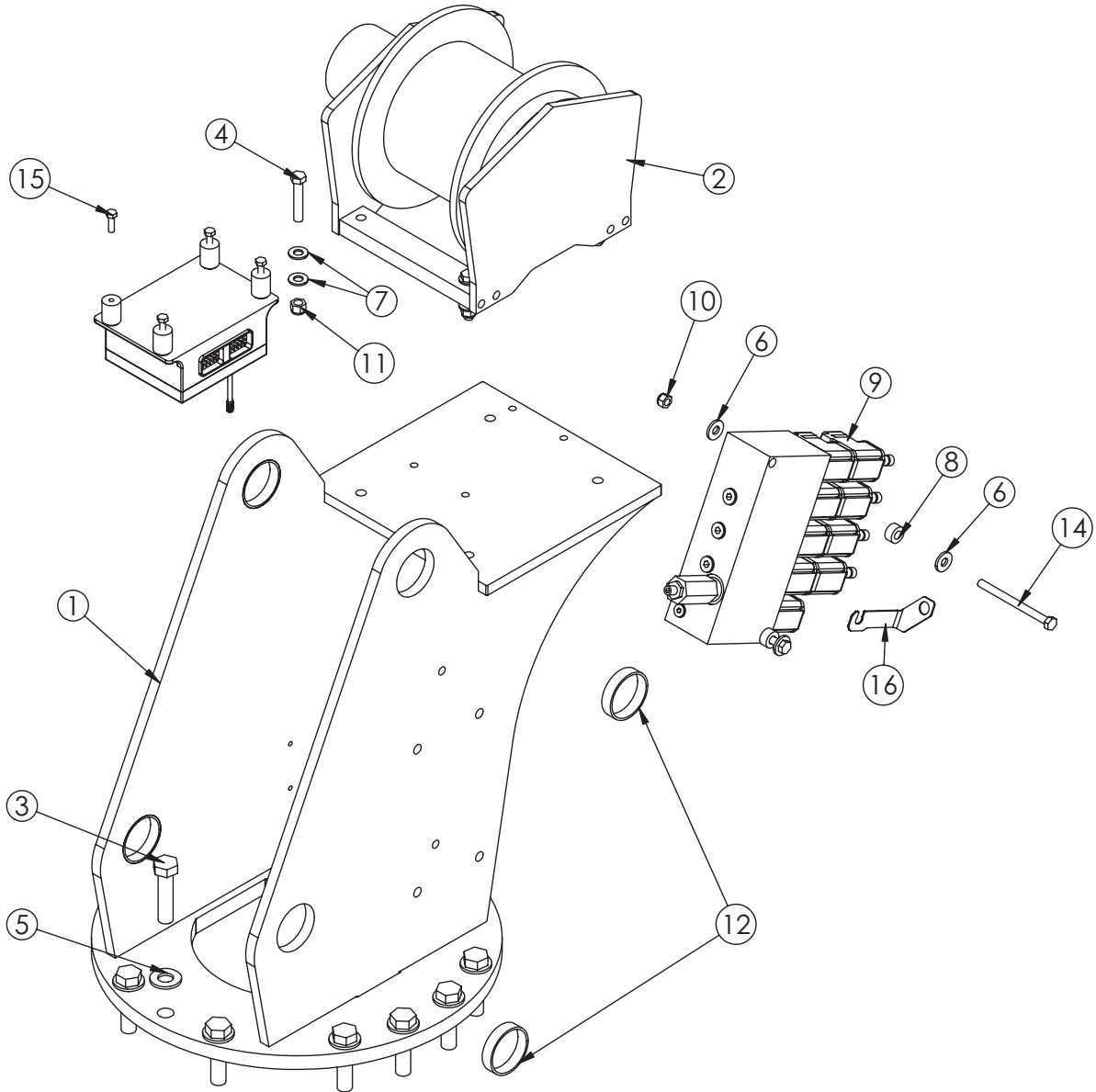

PN 72819

ITEM	PART No.	DESCRIPTION	QTY.
1	72830	MAST 5521 V2	1
2	21528	WINCH 2500 5520 CRANE	1
3	66838	CAP SCR 0.63-11X2.50 HHGR8 W/RED PATCH	14
4	C1006	CAP SCR 0.38-16X2.00 HHGR8	4
5	C5902	WASHER 0.63 SAE FLAT YELLOW GR8	14
6	0343	WASHER 0.31 USS FLAT	5
7	C6353	WASHER 0.38 SAE FLAT YELLOW GR8	8
8	27813	COLLAR 0.38X0.75X0.38 UHMW	2
9	44530	VB 4 SECT W/PROP STER8GPM DEUTSCH	1
10	0342	NUT 0.31-18 HHGR5 NYLOC	2
11	56673	NUT 0.38-16 HHGR8 NYLOC	4
12	57594	BUSHING COMPOSITE FIBER 2.00X.50	4
14	0491	CAP SCR 0.31-18X4.00 HHGR5	2
15	47425	CAP SCR 6MMX20MM HH 8.8(GR5)	4
16	85930	STRAP VALVE RETAINING	1

RADIO RECEIVER RUBBER MOUNT 64977

Main Boom Assembly - PN 72833

**NOTE: INCLINOMETER MOUNTS
INSIDE THE BOOM. VIEW SHOWS
POSITION OF INCLINOMETER**

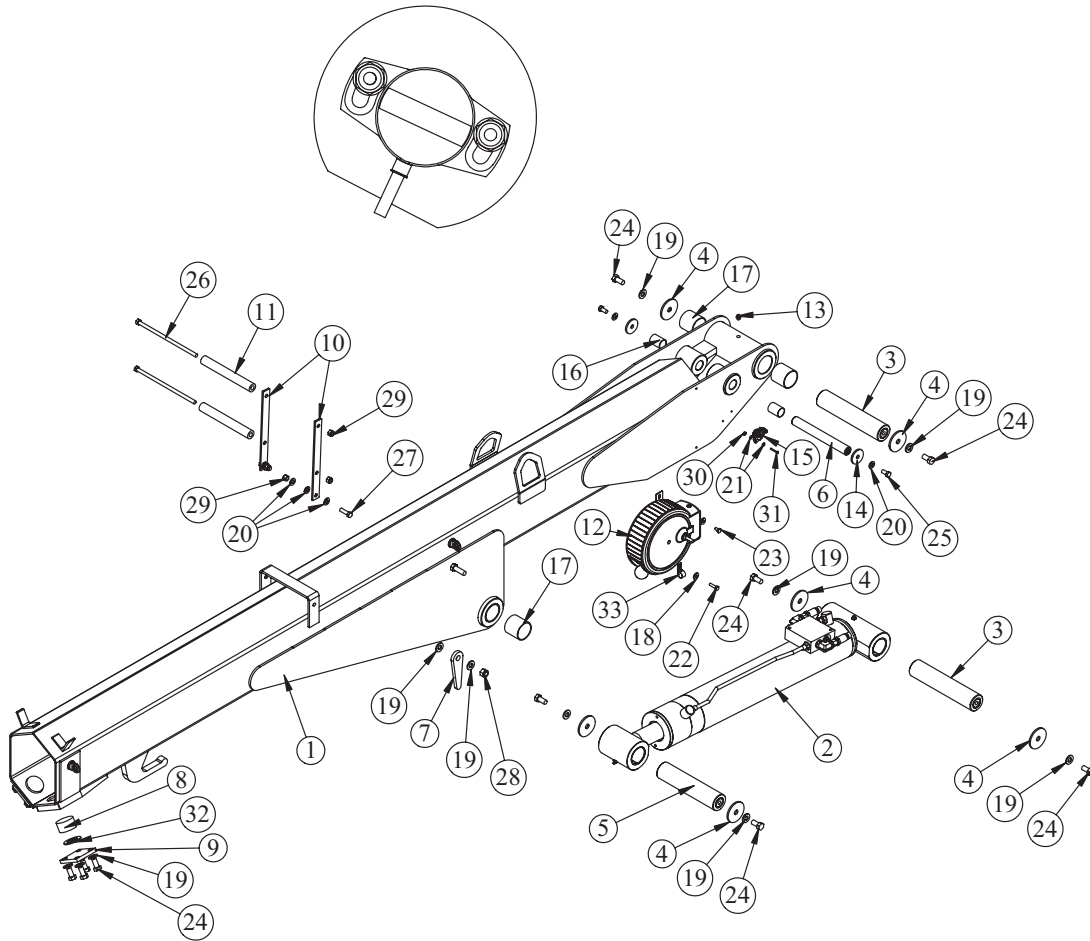

PN 72833

ITEM	PART	DESCRIPTION	QTY.	ITEM	PART	DESCRIPTION	QTY.
1	57287	INNER BOOM 5521	1	15	53493	INCLINOMETER 60 DEG	1
2	78434	CYLINDER ASM 4.00X22.50	1	16	0068	BUSHING BPC16DXR24 1.00X1.50	2
3	26213CR	PIN 2.00X9.63 D&T	2	17	4381	BUSHING BPC32DXR32 2.00X2.00	4
4	9142	PIN CAP 0.56X2.50X0.19 YZ	6	18	0340	WASHER 0.25 USS FLAT	2
5	9711CR	PIN 2.00X8.88 D&T	1	19	D0790	WASHER 0.50 SAE FLAT YELLOW GR8	18
6	9712CR	PIN 1.00X8.38 SR/D&T	1	20	C6353	WASHER 0.38 SAE FLAT YELLOW GR8	8
7	D1194	PLATE ANGLE INDICATOR	2	21	18765	WASHER #6 SAE FLAT	4
8	9363	WEAR PAD 1.12X2.00 RND NYLATRON	2	22	0480	CAP SCR 0.25-20X1.00 HHGR5	1
9	9545	PLATE WEAR PAD SUPPORT	2	23	0478	CAP SCR 0.25-20X0.50 HHGR5	1
10	69470	BRKT ROPE GUIDE 4421	2	24	10172	CAP SCR 0.50-13X1.00 HHGR8	14
11	27720	SPACER ROPE GUIDE 6620 UHMW	2	25	9843	CAP SCR 0.38-16X0.75 HHGR8	2
12	72602	CORD REEL ASM 15/21 FT CRANE	1	26	12168	CAP SCR 0.38-16X9.00 HHGR5	2
13	c1592	ZERK 1/8 NPT STRAIGHT	1	27	0335	CAP SCR 0.38-16X1.25 HHGR5	2
14	9320	PIN CAP 0.44X1.75X0.19 YZ	2	28	C6106	NUT 0.50-13 HHGR5 NYLOC	2
				29	0347	NUT 0.38-16 HHGR5 NYLOC	4
				30	D0076	NUT #6-32 HH NYLOC SS	2
				31	18618	SCREW #6-32X1.00 PHMS PH	2
				32	0425	MACHY WASHER 1.25ID 10GA	2
				33	C0078	CLAMP 0.38 BLK VINYL	1

This page left intentionally blank.

Extension Boom Assembly - PN 58290

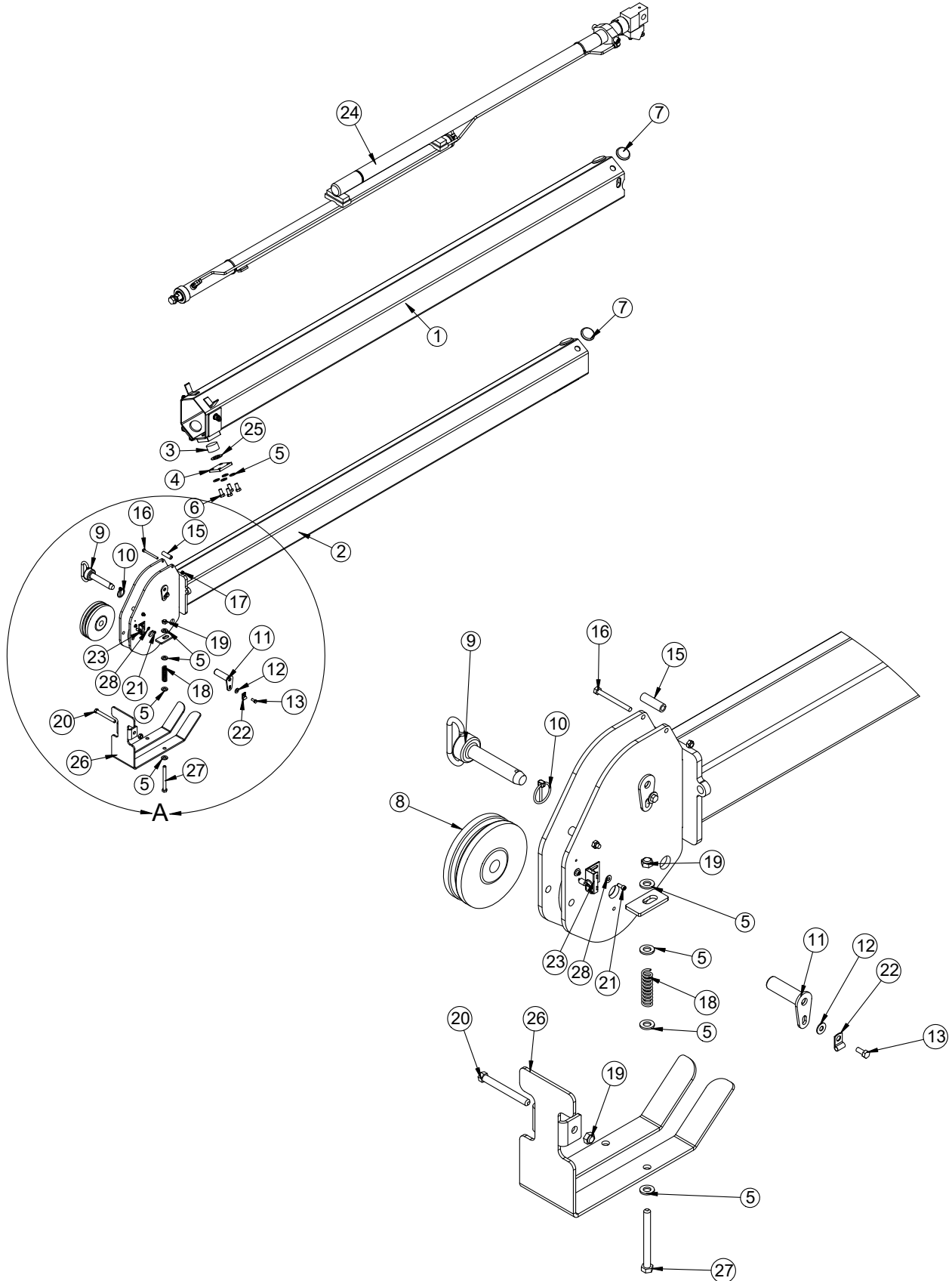

DETAIL A
SCALE 1 : 9

Extension Boom Assembly - PN 58290 Parts List

PN 58290			
ITEM	PART	DESCRIPTION	QTY
1	57307	EXT BOOM 1ST 5521	1
2	51117	EXT BOOM 6620 2ND CRADLE A2B	1
3	9363	WEAR PAD 1.12X2.00 RND	2
4	136654	PLATE WEAR PAD COVER 1ST EXT 55/6521 CORSOL	2
5	D0790	WASHER 0.50 FLAT GR8	16
6	10172	CAP SCR 0.50-13X1.00 HHGR8 ZY	8
7	6252	WEAR PAD 0.34X2.50 RND	4
8	11545	SHEAVE 6620 6.75 DIA .31R/1.94 THK	2
9	12824	PIN HITCH 1.00X4.50	1
10	5753	PIN 0.19X1.56 LYNCH	1
11	9706CR	PIN TEAR DROP 1.00X3.25 ZC	2
12	0343	WASHER 0.31 USS FLAT ZINC	2
13	0420	CAP SCR 0.31-18X0.75 HHGR5	1
14	0484	CAP SCR 0.31-18 X 0.50 HHGR5	1
15	27719	SPACER BOOM TIP 6620 UHMW	2
16	12178	CAP SCR 0.31-18X3.25 HHGR5	2
17	0342	NUT 0.31-18 HH NYLOC	2
18	27710	SPRING ANTI 2 BLOCK CRADLE A2B	2
19	C6106	NUT 0.50-13 HHGR5 NYLOC	3
20	0507	CAP SCR 0.50-13X4.50 HHGR5	1
21	31132	SCREW #10-24X0.50 SH SS	2
22	31279	CLAMP 0.31D 0.75W 0.40HL GALV BLK VINYL	1
23	35105	SWITCH LIMIT E1117-B9111-6C	1
24	49316	CYLINDER EXT ASM 6620 2.0/2.0	1
25	0425	MACHY WASHER 1.25ID 10GA	2
26	51903	PLATE CRADLE 6620/6628 PC BLACK	1
27	C1000	CAP SCR 0.50-13X5.00 HHGR5	2
28	D0178	WASHER #10 SAE FLAT ZINC	2
REV. D			

NOTES:

HARDWARE KITS: 97633, 115654

Extension Boom Assembly - PN 59146

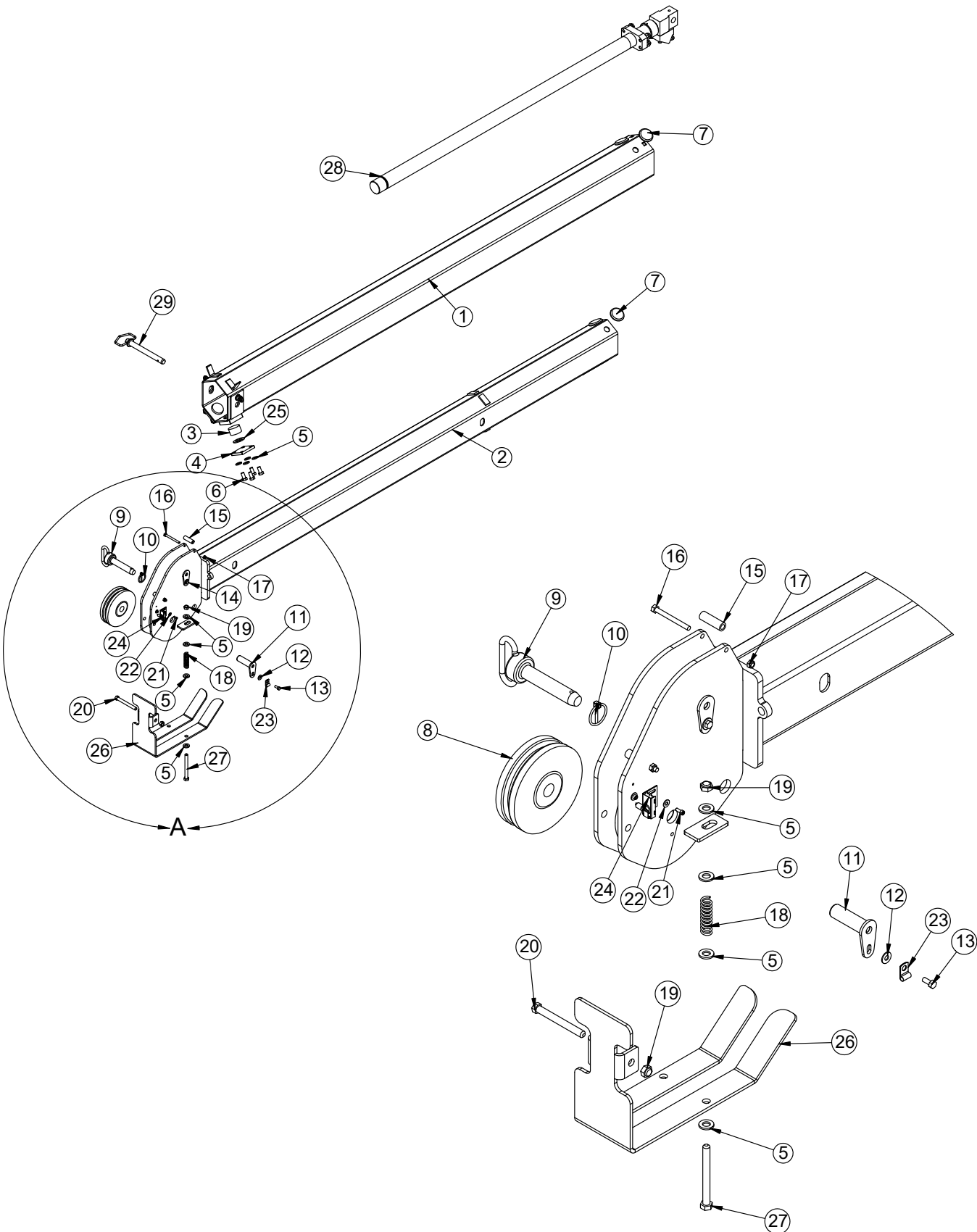

DETAIL A
SCALE 1 : 9

Extension Boom Assembly - PN 59146 Parts List

PN 59146			
ITEM	PART	DESCRIPTION	QTY
1	57925	EXT BOOM 1ST 5521 1H1M	1
2	59147	EXT BOOM 2ND 5521 CRADLE A2B 1H1M	1
3	9363	WEAR PAD 1.12X2.00 RND	2
4	136654	PLATE WEAR PAD COVER 1ST EXT 55/6521 CORSOL	2
5	D0790	WASHER 0.50 FLAT GR8	16
6	10172	CAP SCR 0.50-13X1.00 HHGR8 ZY	8
7	6252	WEAR PAD 0.34X2.50 RND	4
8	11545	SHEAVE 6620 6.75 DIA .31R/1.94 THK	2
9	12824	PIN HITCH 1.00X4.50	1
10	5753	PIN 0.19X1.56 LYNCH	1
11	9706CR	PIN TEAR DROP 1.00X3.25 ZC	2
12	0343	WASHER 0.31 USS FLAT ZINC	2
13	0420	CAP SCR 0.31-18X0.75 HHGR5	1
14	0484	CAP SCR 0.31-18 X 0.50 HHGR5	1
15	27719	SPACER BOOM TIP 6620 UHMW	2
16	12178	CAP SCR 0.31-18X3.25 HHGR5	2
17	0342	NUT 0.31-18 HH NYLOC	2
18	27710	SPRING ANTI 2 BLOCK CRADLE A2B	2
19	C6106	NUT 0.50-13 HHGR5 NYLOC	3
20	0507	CAP SCR 0.50-13X4.50 HHGR5	1
21	31132	SCREW #10-24X0.50 SH SS	2
22	D0178	WASHER #10 SAE FLAT ZINC	2
23	31279	CLAMP 0.31D 0.75W 0.40HL GALV BLK VINYL	1
24	35105	SWITCH LIMIT E1117-B9111-6C	1
25	0425	MACHY WASHER 1.25ID 10GA	2
26	51903	PLATE CRADLE 6620/6628 PC BLACK	1
27	C1000	CAP SCR 0.50-13X5.00 HHGR5	2
28	57936	CYLINDER ASM 5521 1H1M	1
29	57937	PIN HITCH 0.75X8.00	1
REV. E			

NOTES:
HARDWARE KITS: 97633, 115654.

Main Cylinder Assembly - PN 78434

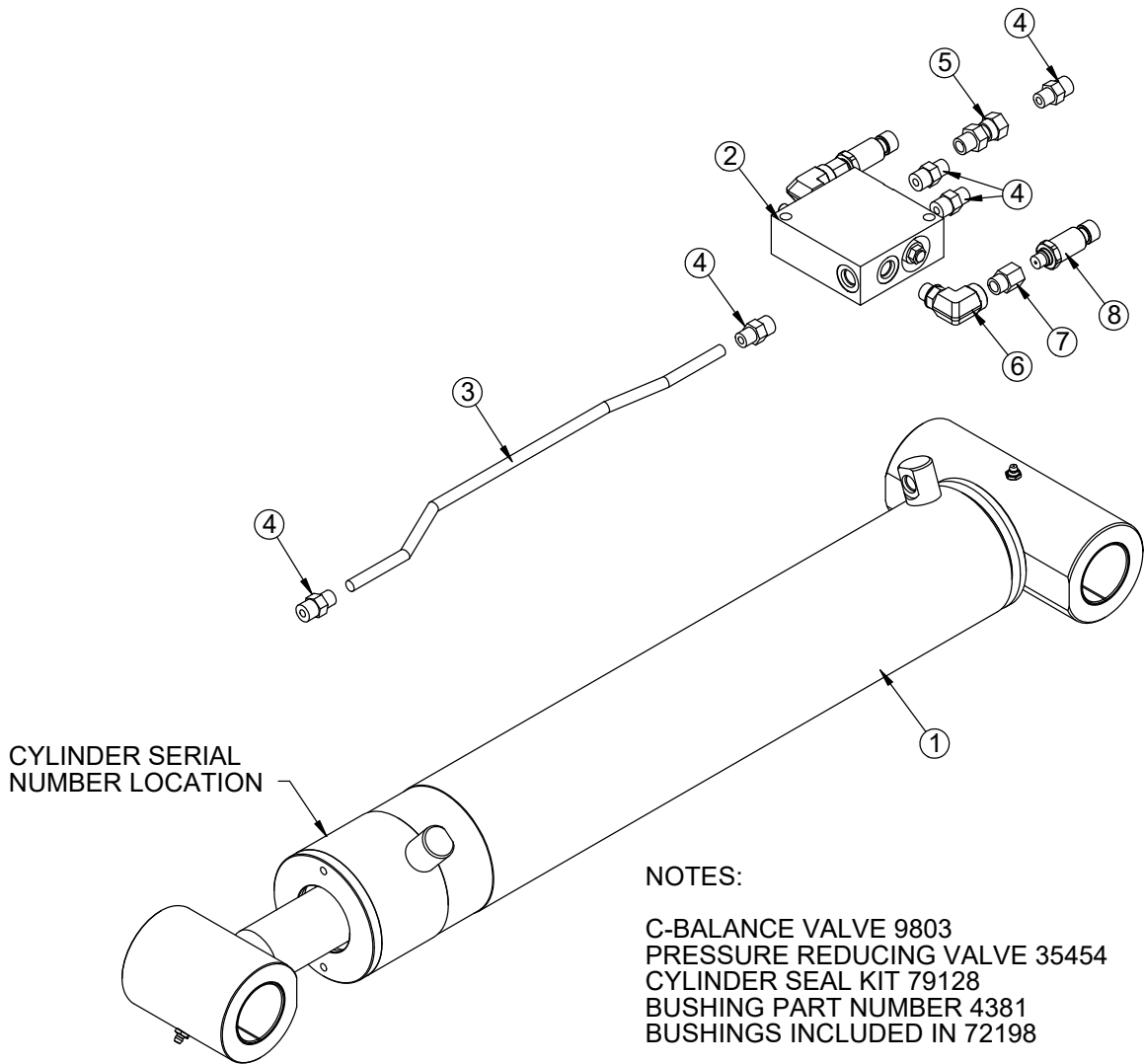

PN 78434

ITEM	PART	DESCRIPTION	QTY
1	72198	CYLINDER 4.00X22.50	1
2	13080	MANIFOLD SINGLE T11A 3500 PSI	1
3	71460	TUBE ASM 0.38X16.72 12630 MAIN CYL ZC	1
4	0279	FTG 6-6 MFS-MORB STRAIGHT	5
5	33743	FTG 6-6 FFSS-MORB STRAIGHT	1
6	3861	FTG 6-6 MAORB-FORB 90	2
7	15111	FTG 6-4 MORB-FORB STRAIGHT REDUCER	2
8	28485	TRANSDUCER PRESSURE 5000 PSI	2

REV. A

Extension Cylinder Assembly (2 Hyd) - PN 49316

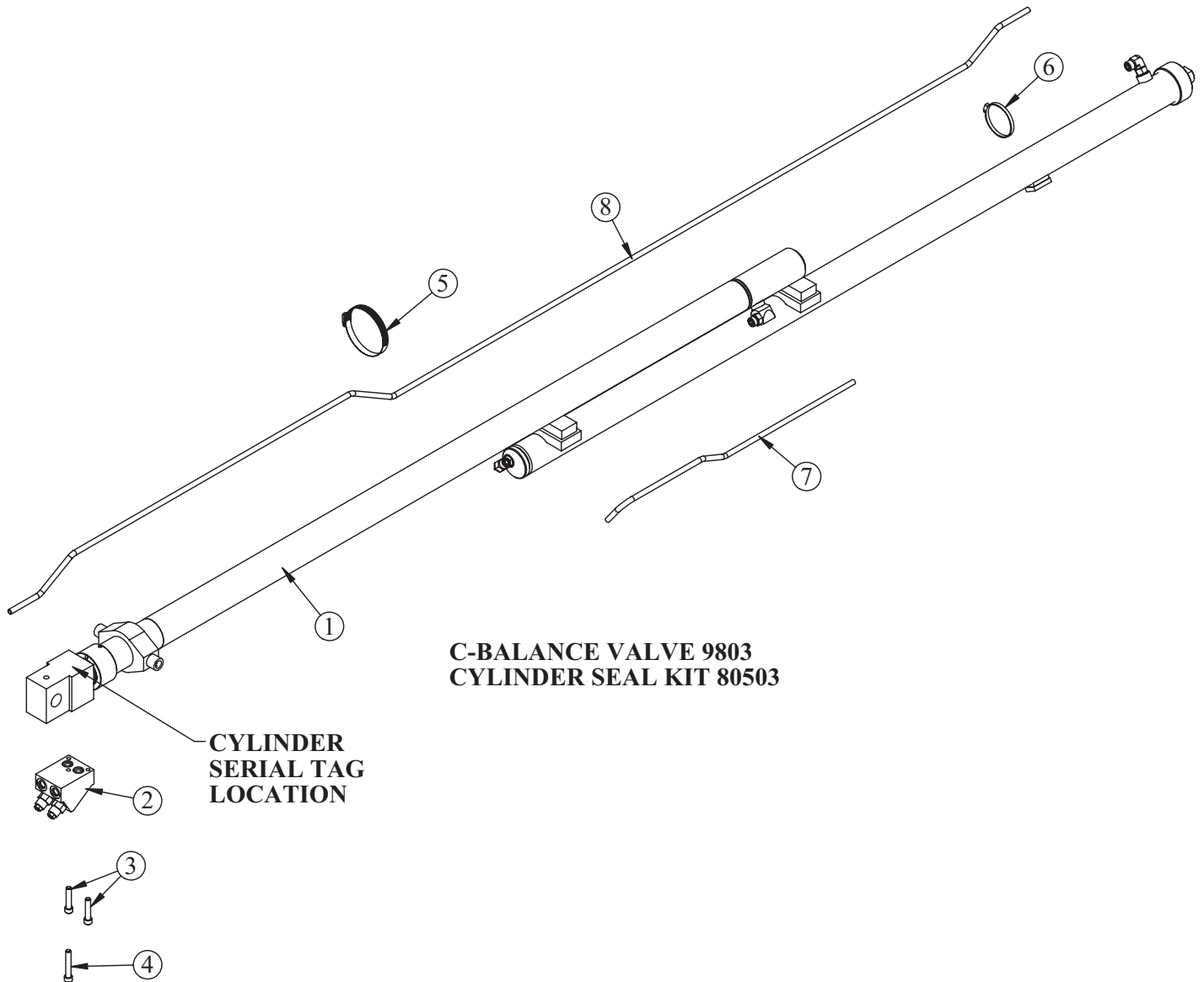

PN 49316

ITEM	PART	DESCRIPTION	QTY.
1	37548	CYLINDER EXT 2 STAGE 2.0/2.0 PTD 60	1
2	14115	MANIFOLD ASM 6620 EXT CBBB-LJN-XVN	1
3	11882	CAP SCR 0.38-16X1.75 SH ZC	2
4	14601	CAP SCR 0.38-16X2.25 SH ZC	1
5	24729	HOSE CLAMP #52 3.00 - 3.75	1
6	D0655	HOSE CLAMP #36 WRM GEAR	1
7	87827	TUBE ASM 0.38X23.25 EXT CYL 7621/12621 YZ	1
8	88393	TUBE ASM 0.38X102.13 EXT CYL 7621/12621 YZ	1

Extension Cylinder Assembly (1 Hyd/1 Manual) - PN 57936

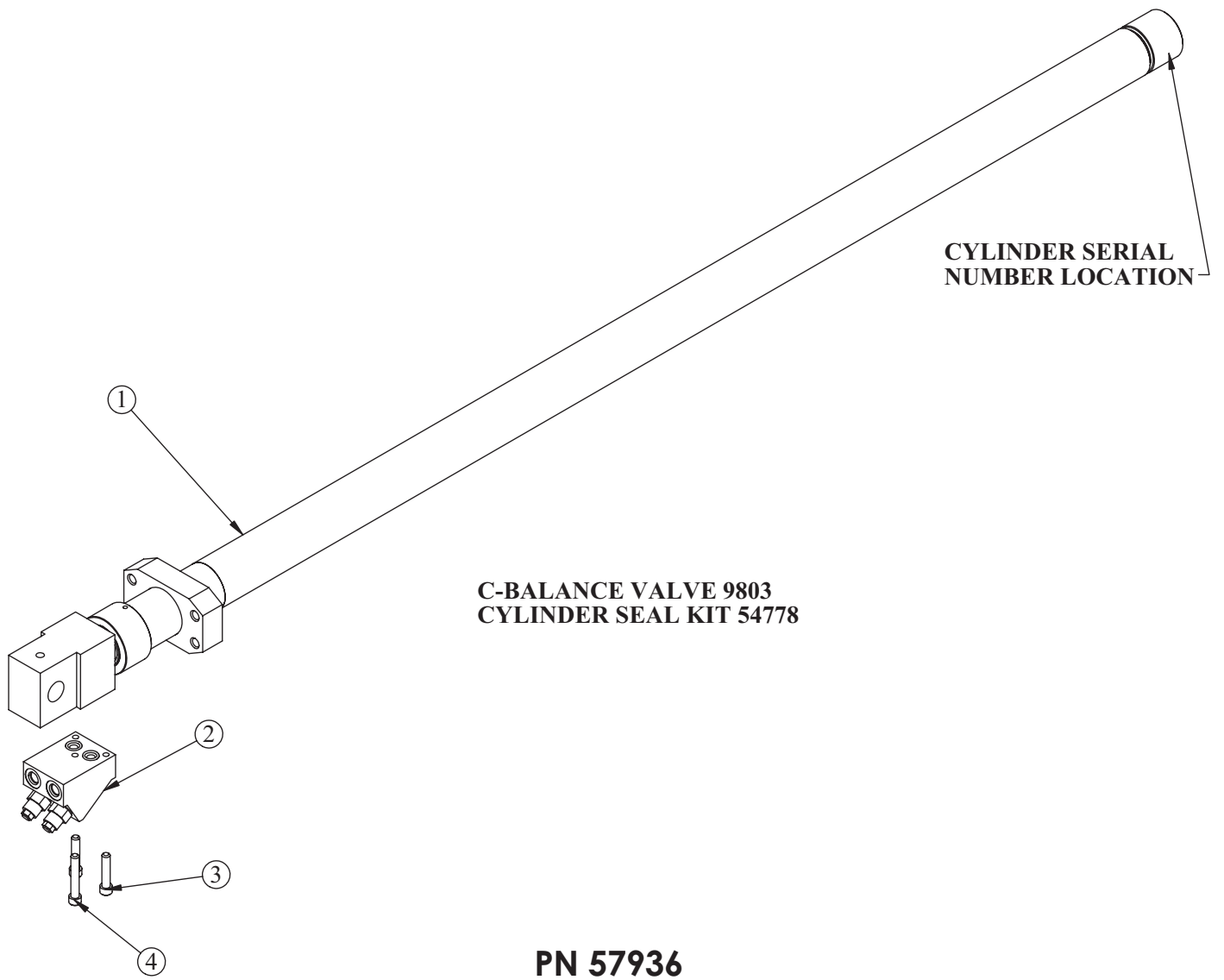

ITEM	PART	DESCRIPTION	QTY.
1	57932	CYLINDER 2.00X60.00 5521 MANUAL	1
2	14115	MANIFOLD ASM 6620 EXT CBBB-LJN-XVN	1
3	11882	CAP SCR 0.38-16X1.75 SH ZC	2
4	14601	CAP SCR 0.38-16X2.25 SH ZC	1

Cable & Hook Assembly - PN 57597

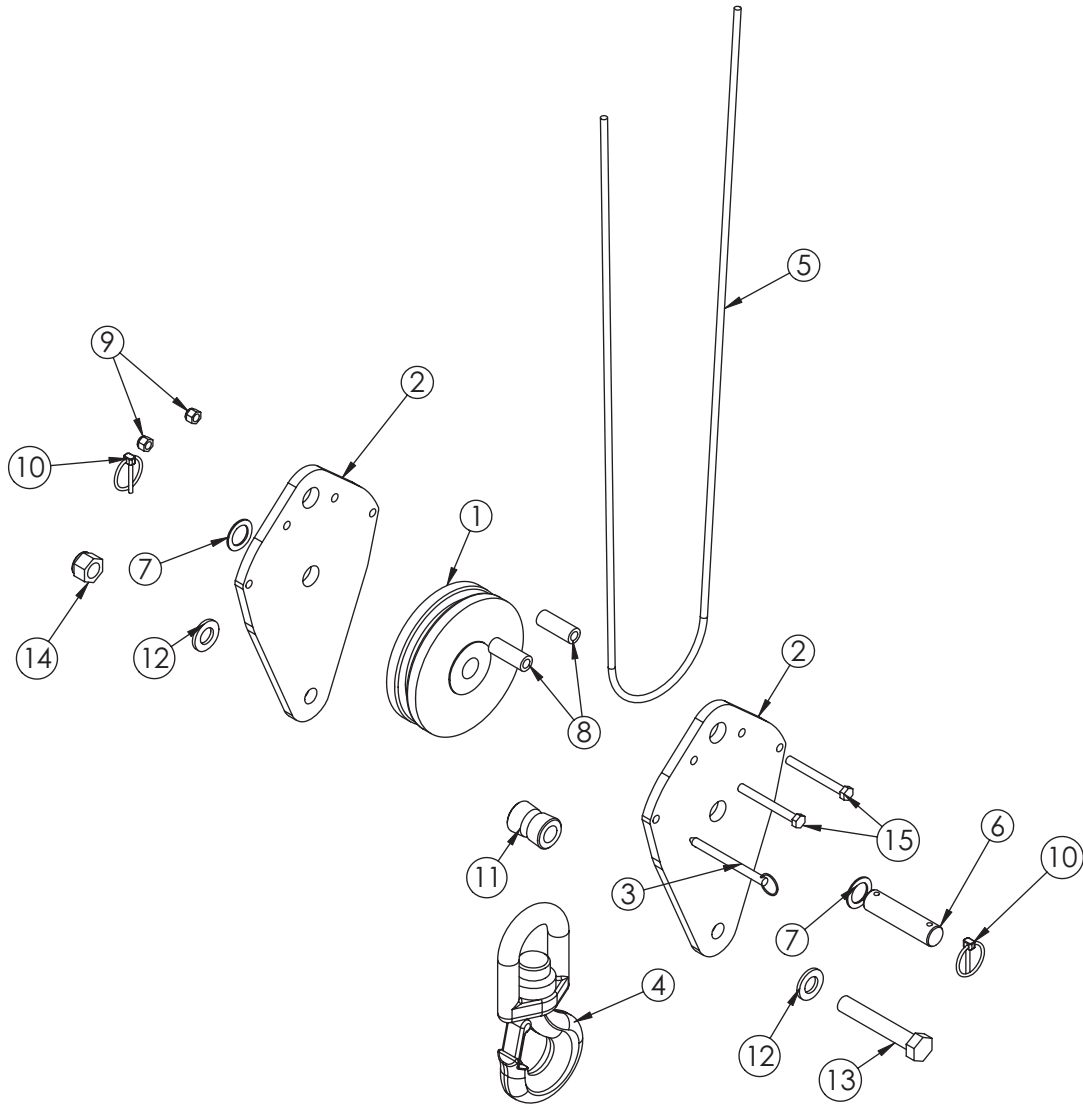

PN 57597

ITEM	PART	DESCRIPTION	QTY.
1	11545	SHEAVE 6620 6.75 DIA .31R/1.94 THK	1
2	57596PC	PLATE SNATCH BLOCK 5521	2
3	13436	PIN .38X4.00 QUICK RELEASE	1
4	25831	HOOK 5 TON SWIVEL CROSBY 1028623	1
5	9610	WIRE ROPE 0.31 6X19 IWRC-XIP 90FT	1
6	39874ZP	PIN 1.00X4.06 COTTER	1
7	0867	MACHY WASHER 1.00ID 14GA	2
8	44643PC	COLLAR 0.44X0.75X2.00	2
9	0347	NUT 0.38-16 HHGR5 NYLOC	2
10	5753	PIN 0.19X1.56 LYNCH	2
11	39844	BUSHING V HOOK	1
12	C6219	WASHER 0.75 SAE FLAT YELLOW GR8	2
13	5841	CAP SCR 0.75-10X4.50 HHGR8	1
14	C0538	NUT 0.75-10 HHGR8 NYLOC	1
15	0531	CAP SCR 0.38-16X3.50 HHGR5	2

Power Unit Assembly - PN 57939

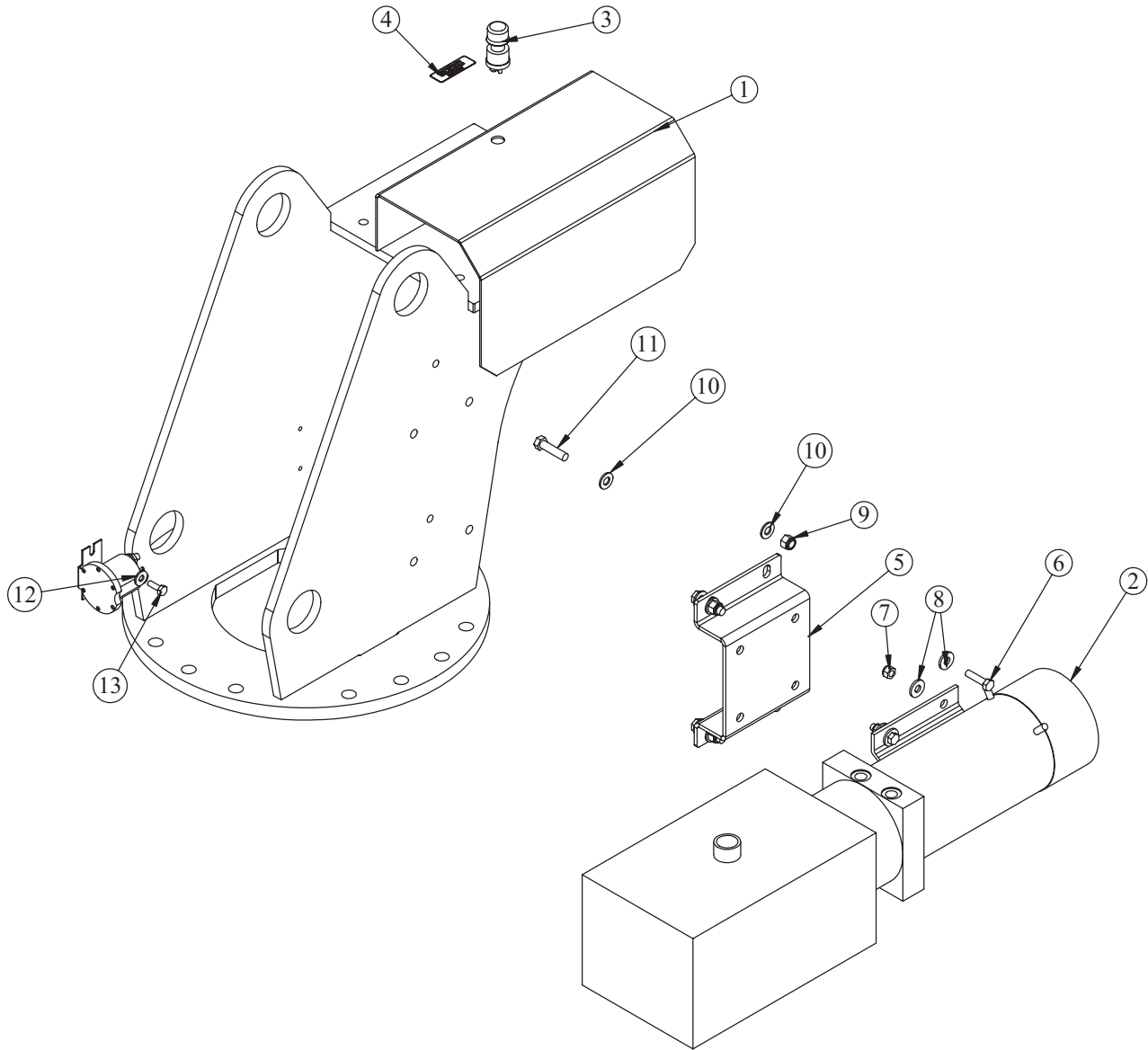

PN 57939

ITEM	PART	DESCRIPTION	QTY.
1	19997	COVER POWER UNIT 5520	1
2	16994	POWER UNIT 12V 5520 HORIZ	1
3	17771	SWITCH PUSH BUTTON 9216-03	1
4	18472	DECAL MANUAL OPERATION 5520	1
5	59136	BRACKET POWER UNIT 5521	1
6	0485	CAP SCR 0.31-18X1.25 HHGR5	4
7	0342	NUT 0.31-18 HHGR5 NYLOC	4
8	0343	WASHER 0.31 USS FLAT	8
9	56673	NUT 0.38-16 HHGR8 NYLOC	4
10	C6353	WASHER 0.38 SAE FLAT YELLOW GR8	8
11	16962	CAP SCR 0.38-16X1.50 HHGR8	4
12	0340	WASHER 0.25 USS FLAT	2
13	0479	CAP SCR 0.25-20X0.75 HHGR5	2

NOTES:

SOLENOID 12V 24956



Subject to Change without Notification.
© 2023 Stellar Industries, Inc.