

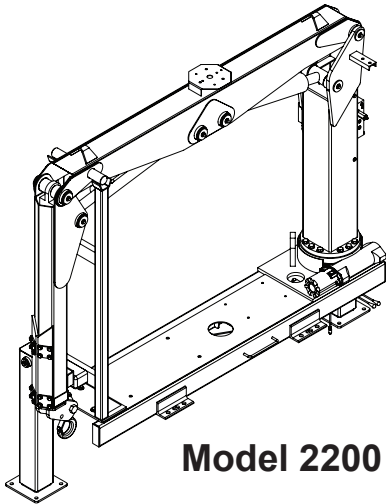

Small OTR Service Cranes Owner's Manual

Safety • Operation • Maintenance • Troubleshooting



Model 2200

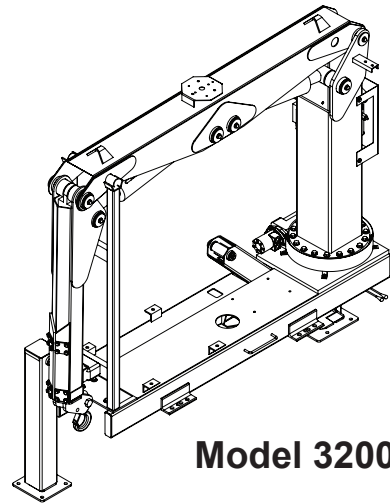

Model 3200

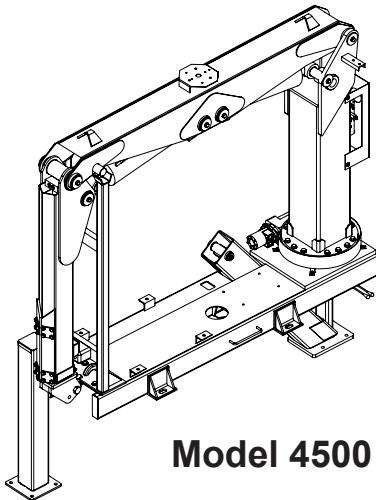

Model 4500

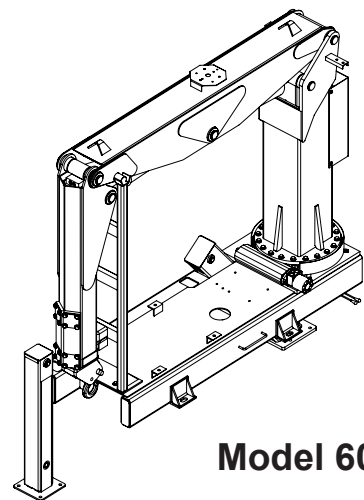

Model 6000

Notice: A copy of this manual must remain with the equipment at all times.
For a printable download copy, please visit: www.stellarindustries.com

Stellar Industries, Inc.

190 State Street

PO Box 169

Garner, IA 50438

800-321-3741

Fax: 641-923-2811

www.stellarindustries.com

WARNING

Operating, maintaining, and servicing a Stellar product may expose you to chemicals including, but not limited to, engine exhaust, carbon monoxide, phthalates, and lead. These chemicals are known to the State of California to cause cancer and birth defects (or other reproductive harm). To keep your exposure to a minimum, be sure to avoid breathing exhaust and service your Stellar product in a well-ventilated area while wearing gloves or washing your hands frequently. For more information, go to www.P65Warnings.ca.gov/passenger-vehicle.

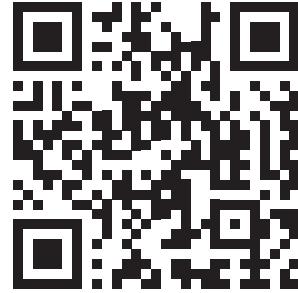

www.p65warnings.ca.gov

NOTICE

Cold Weather Performance

Although clear data on cold weather performance from every steel manufacturer is not available for all types and thicknesses of steel, Stellar Industries is confident that the weldments on our products will operate to 100% of their intended purpose to temperatures down to -40° F / C.

It is recommended if Stellar manufactured equipment needs to be used in temperatures below -40° F / C, the operator should pull the unit into a climate-controlled area and allow the weldments to warm up to and then maintain a temperature above this level.

Serial Tag Location

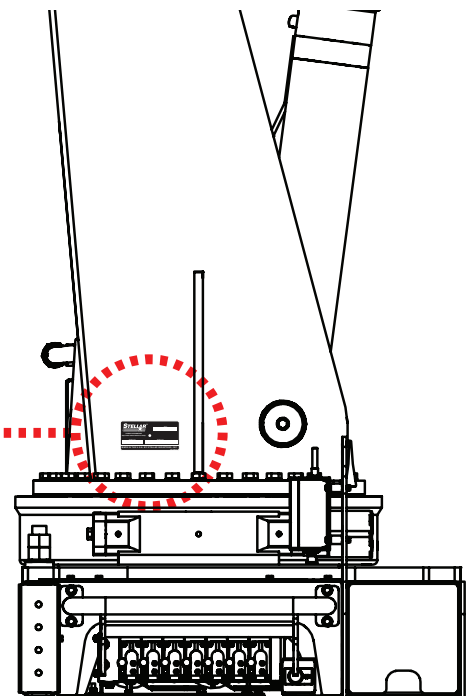
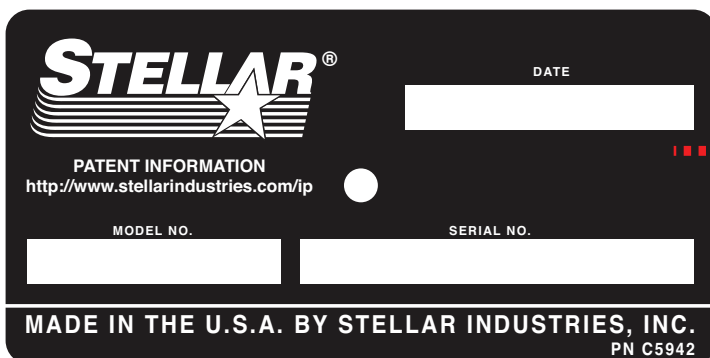

Table of Contents

Introduction	iv
Chapter 1 - Operations.....	1
General Operation	2
Pre-Operation Inspection.....	2
Job Site Setup	3
Step 1: Disengage drive axle and set the parking brake	3
Step 2: Engage the hydraulic power source	3
Step 3: Turn on electrical power	4
Step 4: Position the stabilizers	4
Step 5: Operate the crane	5
Step 6: Stow the crane	7
Step 7: Stow the stabilizers	7
Step 8: Finalize Service.....	7
Step 9: Disengage the hydraulic power source	7
Step 10: Leave the worksite	7
Radio Remote Control Functions	8
Safety Decals of Note.....	9
Chapter 2 - Maintenance.....	11
General Maintenance Guidelines	12
Basic Crane Maintenance Schedule*	12
Hydraulic Oil/Filter Maintenance.....	13
Washing the Crane	13
Paint Maintenance.....	13
PTO and Pump Maintenance	13
Rotation Gear Bearing Maintenance	13
Gear-Bearing Bolt Maintenance	14
Rotation Gear Bearing Thread Tightening Procedure	14
Torque Data Chart	15
Face Seal/O-Ring Size Chart	16
Lubrication Recommendations	17
Washing the Crane:.....	18
New Paint Care and Cleaning Procedures during Initial Ownership and Beyond	18
General Crane Washing Instructions	18
Chapter 3 - Troubleshooting.....	19
Troubleshooting Table	20
Manual Operation	26

Introduction

Stellar® Cranes are designed to provide safe and dependable service for a variety of operations. With proper use and maintenance, these cranes will operate at peak performance for many years.

To promote this longevity, carefully study the information contained in this manual before putting the equipment into service. Though it is not intended to be a training manual for beginners, this manual should provide solid guidelines for the safe and proper usage of the crane.

Once you feel comfortable with the material contained in this manual, strive to exercise your knowledge as you safely operate and maintain the crane. This process is vital to the proper use of the unit.

A copy of this manual is provided with every crane and can be found in the hard plastic manual case that is installed on the chassis. A copy of this manual shall remain with the crane at all times.

Throughout the manual, three signal words will be used to bring attention to important items:

NOTICE

A NOTICE signal word indicates a practice not related to physical injury.

⚠ WARNING

A WARNING signal word indicates a hazardous situation which, if not avoided, could result in death or serious injury.

⚠ DANGER

A DANGER signal word indicates a hazardous situation which, if not avoided, will result in death or serious injury.

Information contained within this manual does not cover all maintenance, operating, or repair instructions pertinent to all possible situations. Please be aware that some sections of this manual contain information pertaining to Stellar® manufactured cranes in general and may or may not apply to your specific model.

This manual is not binding. Stellar Industries, Inc. reserves the right to change, at any time, any or all of the items, components, and parts deemed necessary for product improvement or commercial/production purposes. This right is kept with no requirement or obligation for immediate mandatory updating of this manual.

If more information is required or technical assistance is needed, or if you feel that any part of this manual is unclear or incorrect, please contact the Stellar Customer Service Department by phone at 800-321-3741 or email at service@stellarindustries.com.

Chapter 1 - Operations

CHAPTER CONTENTS

General Operation.....	2
Pre-Operation Inspection	2
Job Site Setup.....	3
Step 1: Disengage drive axle and set the parking brake	3
Step 2: Engage the hydraulic power source	3
Step 3: Turn on electrical power.....	4
Step 4: Position the stabilizers	4
Step 5: Operate the crane.....	5
Step 6: Stow the crane.....	7
Step 7: Stow the stabilizers.....	7
Step 8: Finalize Service	7
Step 9: Disengage the hydraulic power source.....	7
Step 10: Leave the worksite.....	7
Radio Remote Control Functions.....	8
Safety Decals of Note	9

General Operation

Safety should be the number one thought on every operator's mind. Three factors should exist for safe operation: a qualified operator, well-maintained equipment, and the proper use of this equipment.

This chapter contains information regarding the safety and operation of Stellar® Small OTR Service Cranes and should be read and understood completely by everyone working with or near the crane before putting the unit into operation.

⚠ WARNING Failure to follow operating, maintenance, or safety instructions can result in death or serious injury.

It is the responsibility of the owner to instruct the operator in the safe operation of the equipment and to provide the operator with properly maintained equipment.

⚠ WARNING Stellar® Crane operators must conform to the qualifications specified in ANSI B30.5 - Chapter 5-3 Operation. Trainees or untrained persons shall be under the direct supervision of qualified persons.

Operators shall consult with the owner of the equipment regarding current safety regulations and required personal protective equipment.

Please take note that Stellar Industries, Inc. is not liable for accidents incurred by the crane because of non-fulfillment from the operator's side of current rules, laws, and regulations.

Pre-Operation Inspection

Before operating the equipment, make sure all regular maintenance has been performed. Each day, inspect the crane for all of the following:

- Vehicle for standard checks such as proper tire inflation and fluid levels.
- Parking brake operation.
- Hydraulic reservoir for proper oil level.
- Hoses and gearboxes for evidence of oil leaks.
- Crane controls for excessive wear, cleanliness and proper operation.
- Operational aids such as decals for placement and legibility.
- All securing hardware such as cotter pins, snap rings, hairpins, and pin keepers for proper installation.
- All safety guards for proper installation.

Replace/repair as necessary prior to operation. For a more detailed checklist of scheduled inspection points, refer to the Stellar® Crane Inspection Log. This document is an essential guide for the daily, monthly, quarterly and annual inspection tasks that will help maintain the quality of your Stellar product.

Job Site Setup

Thoroughly plan the lift by understanding the work site area and your loads before positioning the vehicle. For a complete and detailed description of job site setup, please refer to the AEM Safety Manual (Form C-70-2). Consider the following:

- The vehicle should be positioned in an area free from bystanders and overhead obstructions. Use a signal person if necessary.
- **⚠ DANGER** Always maintain safe clearance from high voltage power lines in accordance with ANSI B30.5: 5-3.4.5 Operating Near Electric Power Lines. Death or serious injury will result from inadequate clearance if crane, load, or vehicle becomes electrically charged.
- Make certain that the vehicle is parked on stable, flat ground as close to the job as possible. The surface under the service truck must be able to support the weight of the machine and its load.
- Use wheel chocks if parking the vehicle on a slope.
- Always park the vehicle with the grade. If cross-grade parking is required, the load capacity must be decreased appropriately to mitigate tipping risk.
- Park the vehicle perpendicular and at the proper distance to the tire being serviced. The vehicle's proper distance will be determined by multiple variables and can be figured from the crane load chart, size of tire, type of service being performing, and various other factors.
- **⚠ WARNING** Never begin a lift without estimating the load weight and calculating the distance and position on the capacity chart.
- Once the vehicle is properly placed, secure the work area using safety cones.
- **⚠ WARNING** Do not operate the crane during electrical storms.
- In dusty work areas, every effort must be taken to keep dust and sand out of the moving parts of the machinery.
- In high humidity work areas, keep parts as dry as possible and well lubricated.

Step 1: Disengage drive axle and set the parking brake

The drive axle must be disengaged and the parking brake must be set before operating any of the equipment.

Step 2: Engage the hydraulic power source

1. Make certain that the transmission is in neutral/park.
2. Engage the hydraulic power source. If using a PTO, consult the PTO manual for specific instructions if needed. *Note: Allow the hydraulic system oil to warm before operating any of the hydraulic equipment, especially during cold weather.*

Step 3: Turn on electrical power

Locate the desired function on the switch panel inside the cab and activate to power the equipment.

Step 4: Position the stabilizers

Once the PTO is engaged, locate the street side (SS) and curb side (CS) stabilizer control handles. Push the lever down to lower or extend the corresponding stabilizer leg. When the stabilizer makes solid contact with the ground, release the control lever.

⚠ WARNING Keep clear of stabilizer legs during operation. Moving stabilizers can cause serious crushing injuries. Make certain that all personnel are clear of the stabilizer and the ground contact point before operating.

⚠ WARNING Do not raise the rear tires of the truck off the ground with the stabilizers. Confirm that the stabilizers are positioned on stable, flat ground and that the truck is as level as possible both front to rear and side to side. Use stabilizer pads to ensure the proper distribution of weight.

Step 5: Operate the crane

Using the Radio Remote:

To operate the crane using the radio remote control:

1. Make certain that the red e-stop button is in the up position (disengaged).
2. To start up the remote control, follow the instructions provided in the remote control manufacturer's manual.
4. To operate the crane, activate and hold the desired toggle (See Radio Remote Control page for details). The remote control units for these models operate the crane functions proportionally by using the trigger to control the oil flow entering the control valve when a specific toggle is activated. The more you engage the trigger, the faster the crane function will operate.

Note: The Radio remote control is equipped with an emergency stop button. If you encounter a situation that you need to stop the crane functionality immediately, press down on the red Emergency Stop button.

Operating the Crane:

1. Slowly pull the trigger and activate the main boom toggle up to un-stow the crane from travel position.
2. Once the crane is un-stowed, proceed with operating the proper toggles to perform the service.

Lifting the load:

Consider the following:

- When performing a lift, have the load as close to the ground as possible.
- **⚠ WARNING** Never exceed manufacturer's capacity charts and ratings. These ratings are based on the machine's hydraulic, mechanical, and structural design rather than stability. If there is a tire manipulator attached to your crane, use the manipulator load chart, as the weight of the unit must be taken into account.
- Center the crane directly over the load to avoid side loading.
- Make certain that the stabilizers are positioned on flat, stable ground. If the terrain is soft or loose, stabilizer pads may be required. In icy conditions, bolts can be added to the holes in the stabilizer pads for additional traction.
- Never perform a lift that can induce a dynamic force greater than the capacity of the crane.

Step 5: Operate the crane (Cont.)

- It is the responsibility of the operator to know the weight of the handled load to avoid overloading the crane. Do not rely on the overload device to determine maximum rated loads. If the crane is picking more than the maximum rated load, the overload protection device may be malfunctioning. Discontinue use immediately and contact Stellar Customer Service for support.
- **⚠ WARNING** Do not use a crane to lift personnel without factory approved lifting device.
- Do not attempt to lift fixed loads.

Moving the load:

Ensure that the load is secure and balanced before moving:

- Consult the Tire Industry Association (TIA) tire service training materials for proper tire handling.
- Be sure that the crane is level and stable before moving the load.
- Always look for any changes to the surroundings since the job site setup. Be aware of any new or missed overhead obstructions (branches, power lines, etc) and bystanders. Use a signal person if necessary.
- **⚠ WARNING** Never operate the crane with personnel under any part the boom or load. Do not extend or rotate a load over anyone. Never allow personnel to place themselves under any part of the boom or load.
- **⚠ WARNING** Never leave a crane load suspended or unattended.
- Do not use the boom to drag a load.
- Do not use the crane boom to push downward onto anything.
- Avoid sudden starts and stops when moving a load.

Step 6: Stow the crane

When the job is complete, use the correct toggles to bring the crane gently down onto the crane rest.

Step 7: Stow the stabilizers

Retract outriggers using the control levers or switches marked 'outrigger'.

Step 8: Finalize Service

Finalize the service by storing the safety cones, shutting drawers and compartments, and securing the load.

Step 9: Disengage the hydraulic power source

- Disengage the hydraulic power source.
- Turn off all switches on the control panel.
- Stow the radio remote in the cab. If your truck has a docking station, secure the remote prior to leaving the work site.

Step 10: Leave the worksite

The parking brake must be released before moving the truck.

⚠ WARNING Make certain that any air tanks are completely drained before moving the truck.

Radio Remote Control Functions

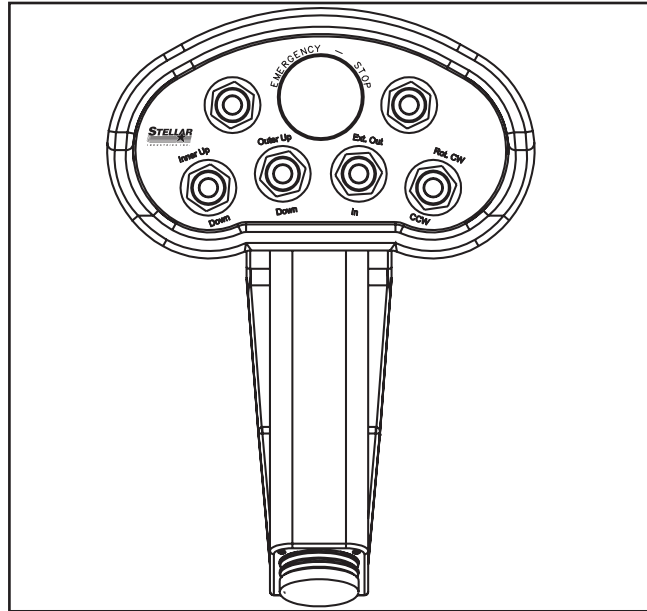

The crane is operated by a radio control system which operates an electronic valve bank. The controller (as shown above) operates the following functions:

- Main Boom Up and Down**
- Outer Boom Up and Down**
- Extension Boom In and Out**
- Rotation Clockwise and Counter-Clockwise**

- The Radio remote control is equipped with an emergency stop button. If you encounter a situation that you need to stop the crane functionality immediately, press down on the red Emergency Stop button. DO NOT use the e-stop as an on/off button, as it is intended solely for safety during emergencies.
- The rechargeable battery included with this equipment is located on the underside of the remote.

Safety Decals of Note

Safety decals serve to inform the viewer of the hazard type, how to avoid the hazard, and the consequences of not avoiding the hazard.

Decals are considered safety equipment. They must be maintained, as would other safety devices. All safety instruction plates, notices, capacity charts and any other decal applied to the crane or service body must be kept legible and in good condition. Replace any decals that are missing, damaged, or illegible.

Detailed below are a number of key safety decals related to this equipment. Use the decal placement drawing in the Installation, Assembly Drawings, and Parts Manual to note the actual location of the safety decals on the equipment.

Body/Chassis

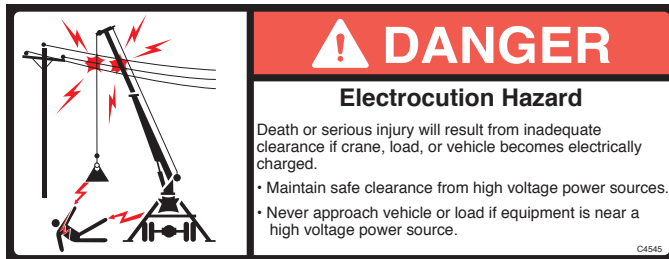

Decal Part Number: C4545

Decal Location: Four corners of the body/chassis

Hazard Type: Electrocutation Hazard

Consequences: Will result in death or serious injury.

Avoidance: Maintain safe clearance from high voltage power sources. Never approach vehicle or load if equipment is near a high voltage power source.

Stabilizers



Decal Part Number: C4795

Decal Location: Each stabilizer leg

Hazard Type: Crush Hazard

Consequences: Can result in death or serious injury.

Avoidance: Keep clear of stabilizer legs during operation.

WARNING

Untrained Operator Hazard

Read and understand all manuals and safety signs before operating or servicing this equipment.

Failure to follow operating, maintenance, or safety instructions can result in death or serious injury.

WARNING

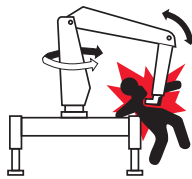

Crush Hazard

Keep clear of crane during operation.

Failure to keep clear of moving crane can result in death or serious injury.

DANGER

Electrocution Hazard

Death or serious injury will result from touching tethered remote if crane, load, or vehicle becomes electrically charged.



Maintain safe clearance from high voltage power sources.

DANGER

Electrocution Hazard

Death or serious injury will result from inadequate clearance if crane, load, or vehicle becomes electrically charged.

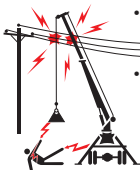

- Maintain safe clearance from high voltage power sources.
- Never approach vehicle or load if equipment is near a high voltage power source.

85504

Decal Part Number: 85504

Decal Location: Each stabilizer leg

Hazard Type: Multiple

Consequences: Multiple

Avoidance: Multiple

Chapter 2 - Maintenance

CHAPTER CONTENTS

General Maintenance Guidelines.....	12
Basic Crane Maintenance Schedule*.....	12
Hydraulic Oil/Filter Maintenance	13
Washing the Crane	13
Paint Maintenance	13
PTO and Pump Maintenance	13
Rotation Gear Bearing Maintenance.....	13
Gear-Bearing Bolt Maintenance.....	14
Rotation Gear Bearing Thread Tightening Procedure.....	14
Torque Data Chart.....	15
Face Seal/O-Ring Size Chart.....	16
Lubrication Recommendations.....	17
Washing the Crane:	18
New Paint Care and Cleaning Procedures during Initial Ownership and Beyond.....	18
General Crane Washing Instructions	18

General Maintenance Guidelines

Maintenance is an important part of extending the life of any Stellar® Crane. Performing key maintenance items on a scheduled program will prevent unnecessary downtime.

Before performing any maintenance to the crane, consider the following:

- **⚠️ WARNING** Only qualified service personnel are to perform maintenance on the crane. Never modify or alter any of the equipment, whether mechanical, electrical, or hydraulic, without explicit approval from Stellar Industries.
- Position the crane where it will be out of the way of other operations or vehicles in the area.
- Stow the boom fully to prevent uncontrolled movement.
- Place all controls in the off position and secure operating features from inadvertent motion. Follow all company directed lockout/tagout procedures.
- Before any service or repair is performed, disengage the hydraulic power source and shut off the engine.
- Allow systems to cool before performing any maintenance.
- Before performing any maintenance on electrical components, disconnect the power source.
- Before performing any maintenance on hydraulic components, relieve hydraulic oil pressure from all hydraulic circuits. Move pedals and control levers repeatedly through their operating positions to relieve all pressures.
- **⚠️ WARNING** Do not disconnect hydraulic hoses while there is still pressure in those components.
- **⚠️ WARNING** Do not touch or grab any hoses that could be under pressure.
- Replace parts with Stellar® approved parts only.
- Keep the crane and service body clean and free from grease build-up, oil and dirt to prevent slippery conditions.
- Label or tag parts when disassembling.
- Immediately repair or have repaired any components found to be inadequate.

Basic Crane Maintenance Schedule*

MAINTENANCE OPERATION	DAILY	WEEKLY	MONTHLY	HOURLY
CHECK HYDRAULIC RESERVOIR OIL LEVEL	X			
GREASE ROTATION GEAR INNER RACE BEARINGS		X		
GREASE ROTATION GEAR WORM DRIVE BEARINGS			3-MONTHS	
GREASE ROTATION GEAR OPEN GEAR TEETH.			X	
GREASE ALL CYLINDER PIVOT POINTS			X	
DRAIN AND REPLACE HYDRAULIC OIL				6500
TIGHTEN ALL HYDRAULIC LINES.			6-MONTHS	

* For a more detailed outline of scheduled inspection points, refer to the Stellar® Crane Inspection Log. The Stellar® Crane Inspection Log is an essential guide for the daily, monthly, quarterly and annual inspection tasks that will help maintain the quality of your Stellar product.

Hydraulic Oil/Filter Maintenance

Stellar Industries recommends the first filter change to occur after the first 250 hours of service. The second, and every subsequent change, should occur after every 1,000 hours of service. By following these guidelines, the hydraulic oil should last up to 6,500 hours.

Note: These recommendations are based on normal working parameters. If operating in less than favorable conditions (excessive dust, moisture, etc.), be sure to check the filter gauge often for filter change notice.

Washing the Crane

Important: Prior to washing the Stellar crane, all electrical components must be covered to prevent any water from being injected into the plastic housing. Avoid any direct water pressure to any of the electrical components.

Paint Maintenance

Touch up any chips or scratches to prevent further paint damage.

PTO and Pump Maintenance

Every six (6) months, remove the hydraulic pump from the PTO and lubricate the splines using Stellar PN 20885. Failure to lubricate shaft splines will cause damage to the PTO and Hydraulic pump.

Rotation Gear Bearing Maintenance

Rotation Worm Gear and Open Gear Teeth

Use a heavy Moly Lube grease (Stellar PN 4460) to lubricate the worm gear and open gear teeth of the rotation bearing. Slowly rotate the crane while pumping the grease between the worm and rotation gear. This should be greased every month or sooner depending on the usage of the crane. Another way of applying the grease would be to remove the gear guard and brush the Molube grease between the gear teeth of the rotation bearing.

NOTICE

Do not lubricate the worm and rotation gear teeth with EP2 grease. EP2 grease will wipe the Molube grease clean causing excessive wear.

Worm Gear Bearings and Races

Apply three (3) pumps of EP2 grease to the two grease zerks located on the side of the Rotation Gear bearing; every three months. After adding the EP2 grease, rotate the crane fully.

Inner Gear Bearing Race

The grease zerk for the inner race bearing is located on the compartment drip tray. The inner race will need to be lubricated with EP2 Grease weekly. The first week grease the inner race bearing at the one (1), three (3), five (5), seven (7), nine (9), and eleven (11) o'clock positions. The following week, grease the inner race bearing in the two (2), four (4), six (6), eight (8), ten (10) and twelve (12) o'clock positions. Rotate lubrication points every week.

Gear-Bearing Bolt Maintenance

Once a bolt has been torqued to 75% of its proof load and then removed, the torque coefficient may no longer be the same as when the bolt was new thus giving indeterminate clamp loads after torquing.

⚠ WARNING Anytime a torqued gear-bearing bolt is removed, it must be replaced with a new bolt of the identical grade and size.

NOTICE Always use Red Loctite Threadlocker sealant to secure the new bolt.

Rotation Gear Bearing Thread Tightening Procedure

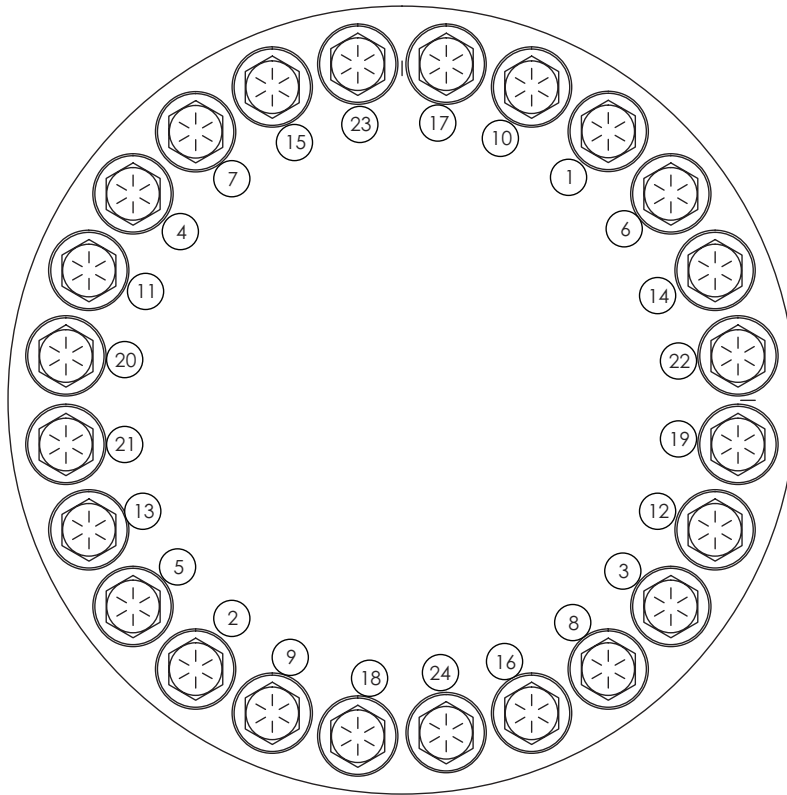

Step 1: Refer to the Torque Data Chart on the previous page to determine the proper torque value based on the size of bolt used.

Step 2: Torque all bolts to approximately 40% of the specified torque value using the tightening sequence shown above. Note: The number of bolts may be different than shown in the diagram but the sequence will work using the same pattern in relation to Bolt #1.

Step 3: Torque all bolts to 75% of the specified torque value using the tightening sequence shown above.

Step 4: Torque all bolts to the listed torque value using the tightening sequence shown above.

Torque Data Chart

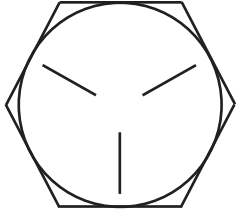
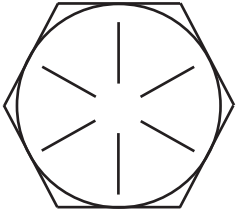
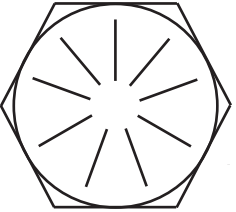
		GRADE 5		GRADE 8		GRADE 9
						
SIZE (DIA-TPI)	BOLT DIA (INCHES)	PLAIN (FT-LB)	PLATED (FT-LB)	PLAIN (FT-LB)	PLATED (FT-LB)	PLATED (FT-LB)
5/16-18	0.3125	17	13	25	18	22
3/8-16	0.3750	31	23	44	33	39
7/16-14	0.4375	49	37	70	52	63
1/2-13	0.5000	75	57	105	80	96
9/16-12	0.5625	110	82	155	115	139
5/8-11	0.6250	150	115	220	160	192
3/4-10	0.7500	265	200	375	280	340
7/8-9	0.8750	395	295	605	455	549
1-8	1.000	590	445	910	680	823
1 1/8-7	1.1250	795	595	1290	965	1167
1 1/4-7	1.2500	1120	840	1815	1360	1646
1 3/8-6	1.3750	1470	1100	2380	1780	2158
1 1/2-6	1.500	1950	1460	3160	2370	2865

NOTE:

When using the torque data in the chart, the following rules should be observed:

- Bolt manufacturer’s particular specifications should be consulted when provided.
- Flat washers of equal strength must be used.
- All torque measurements are given in foot-pounds. To convert to inch-pounds, multiply by 12.
- Torque values specified are for bolts with residual oils or no special lubricants applied.
- Torque values for socket-head capscrews are the same as for grade 8 capscrews.
- Do not use these values if a different torque value or tightening procedure is given for a specific application. Torque values listed are for general use only. Check tightness of fasteners periodically.
- Shear bolts are designed to fail under predetermined loads. Always replace shear bolts with identical grade.
- Fasteners should be replaced with the same or higher grade. If higher grade fasteners are used, these should only be tightened to the strength of the original.
- Tighten plastic insert or crimped steel-type lock nuts to approximately 110 percent of the dry torque values shown in the chart below, applied to the nut, not to the bolt head. Tighten toothed or serrated-type lock nuts to the full torque value. **Note: “Lubricated” means coated with a lubricant such as engine oil, or fasteners with phosphate and oil coatings. “Dry” means plain or zinc plated without lubrication. Tighten lubricated bolts to approximately 80% of dry bolts.**

Face Seal/O-Ring Size Chart

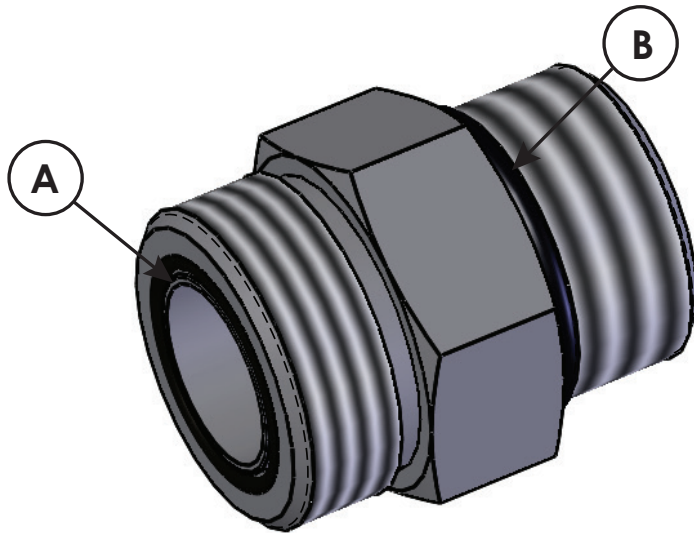









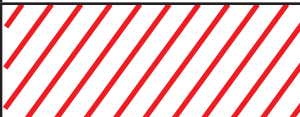

Hose Size	Fitting Size	Face Seal (A) Stellar® PN	O-ring Boss (B) Stellar® PN
1/4"	#4	C2027	D1245
3/8"	#6	C2028	D1246
1/2"	#8	C2029	D1247
5/8"	#10	32223	D1248
3/4"	#12	D1244	D1249
1"	#16		D1250

Lubrication Recommendations

CRANE LUBRICATION		
COMPONENT	LOCATION	RECOMMENDATION
HYDRAULIC SYSTEM	RESERVOIR	RBELOW -5°F HIGH VI, LOW POUR, ISO 22, AW HYDRAULIC OIL
		-5°F TO 90°F HIGH VI, LOW POUR, ISO 32, AW HYDRAULIC OIL
		ABOVE 90°F ISO 46, AW HYDRAULIC OIL
OPEN GEAR TEETH	CRANE ROTATION GEAR	MOLY GREASE 936SF HEAVY (STELLAR PN 4460)
WORM DRIVE BEARINGS (INCLUDING TURNTABLE BEARING INNER RACE)	CRANE ROTATION GEAR, INSIDE CRANE COMPARTMENT	EP2 LITHIUM COMPLEX GREASE (STELLAR PN 78090)
CYLINDERS	CRANE PIVOT AREAS	EP2 LITHIUM COMPLEX GREASE (STELLAR PN 78090)
CRANE PINS & BUSHINGS	CRANE PIVOT POINTS	EP2 LITHIUM COMPLEX GREASE (STELLAR PN 78090)
WEAR PAD LUBRICATION	N EXTENSION BOOMS	SYNTHETIC LUBRICANT CONTAINING TEFLON®
COMPRESSOR LUBRICATION		
COMPONENT	LOCATION	RECOMMENDATION
RECIPROCATING SINGLE STAGE	COMPRESSOR CRANKCASE	ISO 100 COMPRESSER OIL
RECIPROCATING DOUBLE STAGE	COMPRESSOR CRANKCASE	ISO 100 COMPRESSER OIL
SCREW COMPRESSOR	COMPRESSOR CRANKCASE	-15°F TO 86°F SYNTHETIC PERFORMING ISO 32 COMPRESSER OIL
		-23°F TO 100°F SYNTHETIC PERFORMING ISO 46 COMPRESSER OIL
		32°F TO 113°F SYNTHETIC PERFORMING ISO 68 COMPRESSER OIL

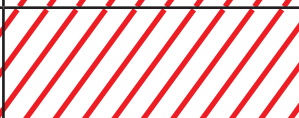
Washing the Crane:

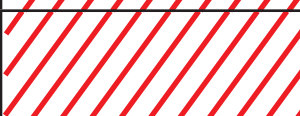
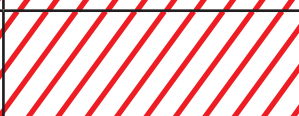
New Paint Care and Cleaning Procedures during Initial Ownership and Beyond

	0 to 30 days past manufacturing date	30 to 60 days past manufacturing date	After 60 days past manufacturing date	Any day paint surface is hot due to exposure to daylight
Water-only Rinse to Clean	<ul style="list-style-type: none"> low pressure no soap 			
Wax				
Handheld Pressure Washer			<ul style="list-style-type: none"> distance > 4 inches pressure < 1700 psi water temp < 120° F neutral pH detergent 	
Automated Wash System			<ul style="list-style-type: none"> pressure < 1700 psi water temp < 120° F neutral pH detergent non-abrassive brushes 	

General Crane Washing Instructions

Follow the parameters above while washing the crane at least once per week, especially when exposed to a dusty, acidic, or alkaline environment. This will maximize durability of the paint, wiring, and rubber material by removing corrosive substances collected from roads or job sites. When washing the crane, avoid direct water spray toward electrical components such as floodlights, radio remote receivers, the VEC center, and areas of the crane which may have rock chips. Avoid the use of stiff bristles. Use of a soft cloth or felt brush is recommended.

Although contact with anti-freeze, gasoline, hydraulic fluid, oil, or windshield washer fluid is expected with this type of equipment, washing these products from your paint surface in a timely manner will greatly enhance the life of your paint finish. Some compounds could be especially damaging to the paint finish and should be removed as soon as possible by rinsing with warm water at a minimum.

NOTICE

Exposure time causing potential paint damage by hydraulic fluid and oil is reduced if the paint surface is hot.

Chapter 3 - Troubleshooting

CHAPTER CONTENTS

Troubleshooting Table	20
Manual Operation.....	26

Troubleshooting

This chapter will list a number of potential problems that may occur while operating the crane. Most problems are easily solved using the solutions portion of this chapter. If problems persist, please contact Customer Service at Stellar Industries 1-800-321-3741.

Serial Tag Location

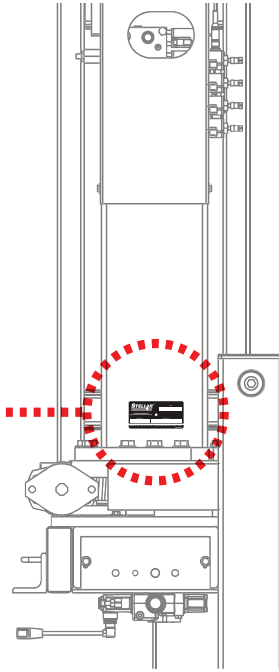
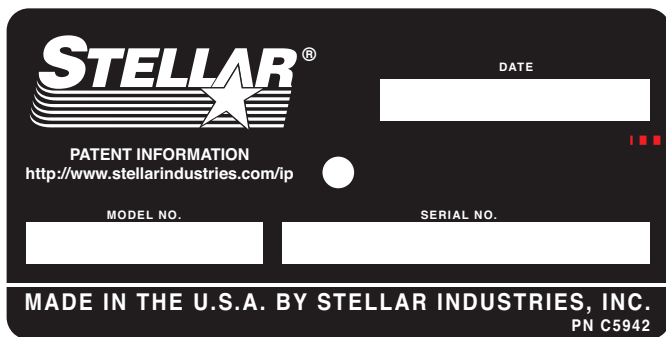

Prior to troubleshooting:

Always make sure the parking brake is engaged and the PTO is engaged (if equipped).

To determine if there is an electrical or hydraulic problem, first try to operate the crane manually (See Manual Operation at end of this chapter). If the crane operates, there will be an electrical problem to trace. If the crane does not operate using the manual overrides, there is a problem within the hydraulic circuit.

Problem - Possible Cause - Possible Solution Table

PROBLEM	POSSIBLE CAUSE	POSSIBLE SOLUTION
CRANE WILL NOT OPERATE	PTO IS NOT ENGAGED	ENGAGE PTO. IF PTO WON'T ENGAGE, REFER TO PTO MANUFACTURER'S MANUAL FOR DETAILS
	CRANE IS NOT RECEIVING PROPER HYDRAULIC FLOW	CHECK HYDRAULIC RESERVOIR FLUID LEVEL
		ENSURE PTO IS ENGAGED
		ENSURE PANIC BAR E-STOP IS NOT ENGAGED
		VERIFY SELECTOR SWITCH IS IN CRANE MODE AND NOT STABILIZER/OFF MODE
		ENSURE DUMP VALVE IS RECEIVING PROPER ELECTRICAL SIGNAL AND OPERATING PROPERLY
		VERIFY HYDRAULIC PUMP IS PRODUCING PROPER FLOW
		ENSURE HYDRAULIC OIL IS AT THE PROPER OPERATING TEMPERATURE
	CRANE IS NOT RECEIVING PROPER HYDRAULIC PRESSURE	CHECK HYDRAULIC RESERVOIR FLUID LEVEL
		ENSURE PTO IS ENGAGED
		ENSURE PANIC BAR E-STOP IS NOT ENGAGED
		VERIFY SELECTOR SWITCH IS IN CRANE MODE AND NOT STABILIZER/OFF MODE
		ENSURE DUMP VALVE IS RECEIVING PROPER ELECTRICAL SIGNAL AND OPERATING PROPERLY
		VERIFY HYDRAULIC PUMP IS PRODUCING PROPER PRESSURE
		CRANE DOES NOT HAVE PROPER ELECTRICAL POWER
	VERIFY GOOD GROUND	
	VERIFY GOOD POWER SUPPLY	
	VERIFY PROPER VOLTAGE	
	VERIFY ELECTRICAL WIRING/ CONNECTION INTEGRITY	
	ENSURE MANUAL/REMOTE SWITCH IS WORKING PROPERLY	

PROBLEM	POSSIBLE CAUSE	POSSIBLE SOLUTION		
CRANE WILL NOT OPERATE	CRANE DOES NOT HAVE PROPER ELECTRICAL POWER	VERIFY ENGINE SPEED CONTROL HAS BEEN ACTIVATED.		
	RADIO CONTROL SYSTEM IS NOT FUNCTIONING	ENSURE MANUAL/REMOTE SWITCH IN THE 'REMOTE' POSITION		
		ENSURE TRANSMITTER IS PROPERLY STARTED. REFER TO THE RADIO SYSTEM MANUFACTURER'S MANUAL FOR DETAILS		
		VERIFY RECEIVER IS GETTING PROPER ELECTRICAL POWER		
		ENSURE TRANSMITTER BATTERY IS CHARGED		
		IF ERROR CODE IS DISPLAYED, REFER TO THE RADIO SYSTEM MANUFACTURER'S MANUAL FOR DETAILS		
		ENSURE E-STOP SWITCH IS NOT ENGAGED		
	MANUAL CONTROL SYSTEM IS NOT FUNCTIONING	ENSURE MANUAL/REMOTE SWITCH IN THE 'MANUAL' POSITION		
		ENSURE E-STOP IS NOT ENGAGED		
	CRANE OPERATES SLOWLY.	CRANE IS NOT RECEIVING PROPER HYDRAULIC FLOW	CHECK HYDRAULIC RESERVOIR FLUID LEVEL.	
ENSURE PTO IS ENGAGED				
ENSURE PANIC BAR E-STOP IS NOT ENGAGED				
VERIFY SELECTOR SWITCH IS IN CRANE MODE AND NOT STABILIZER/OFF MODE				
ENSURE DUMP VALVE IS RECEIVING PROPER ELECTRICAL SIGNAL AND OPERATING PROPERLY				
VERIFY HYDRAULIC PUMP IS PRODUCING PROPER FLOW				
ENSURE HYDRAULIC OIL IS AT THE PROPER OPERATING TEMPERATURE				
VERIFY ENGINE SPEED CONTROL HAS BEEN ACTIVATED				
CRANE IS NOT RECEIVING PROPER HYDRAULIC PRESSURE		CHECK HYDRAULIC RESERVOIR FLUID LEVEL		
		ENSURE PTO IS ENGAGED		
		ENSURE PANIC BAR E-STOP IS NOT ENGAGED		
		VERIFY SELECTOR SWITCH IS IN CRANE MODE AND NOT STABILIZER/OFF MODE		
		ENSURE DUMP VALVE IS RECEIVING PROPER ELECTRICAL SIGNAL AND OPERATING PROPERLY		
		VERIFY HYDRAULIC PUMP IS PRODUCING PROPER PRESSURE		
		CRANE OPERATES SLOWLY	CRANE DOES NOT HAVE PROPER ELECTRICAL POWER	CHECK FUSE AND HOLDER

PROBLEM	POSSIBLE CAUSE	POSSIBLE SOLUTION
CRANE OPERATES SLOWLY	CRANE DOES NOT HAVE PROPER ELECTRICAL POWER	VERIFY GOOD GROUND
		VERIFY PROPER VOLTAGE
		VERIFY ELECTRICAL WIRING/ CONNECTION INTEGRITY
		ENSURE MANUAL/REMOTE SWITCH IS WORKING PROPERLY
		VERIFY ENGINE SPEED CONTROL HAS BEEN ACTIVATED
	REMOTE TRANSMITTER IS IN SNAIL MODE	SWITCH REMOTE FROM SNAIL MODE TO NORMAL MODE
CRANE WILL OPERATE MANUALLY BUT WILL NOT OPERATE ELECTRICALLY	REMOTE/MANUAL SWITCH IS IN THE 'MANUAL' POSITION	TOGGLE THE REMOTE/MANUAL SWITCH TO THE 'REMOTE' POSITION. ENSURE THE SWITCH IS WORKING PROPERLY
	RADIO RECEIVER DISPLAYING AN ERROR CODE.	REFER TO RADIO SYSTEM MANUFACTURER'S MANUAL
	TRANSMITTER IS NOT PROPERLY STARTED	START UP TRANSMITTER PROPERLY - REFER TO MFG MANUAL.
CRANE WILL OPERATE ELECTRICALLY BUT WILL NOT OPERATE MANUALLY	REMOTE/MANUAL SWITCH IS IN THE 'REMOTE' POSITION	TOGGLE THE REMOTE/MANUAL SWITCH TO THE 'MANUAL' POSITION. ENSURE THE SWITCH IS WORKING PROPERLY
NOT ALL CRANE FUNCTIONS OPERATE USING THE RADIO REMOTE TRANSMITTER OR CRANE PERATED INTERMITTENTLY	RADIO RECEIVER DISPLAYING AN ERROR CODE	REFER TO RADIO SYSTEM MANUFACTURER'S MANUAL
CYLINDER DRIFTS OUTWARD OR DOWNWARD	COUNTER BALANCE VALVES ARE NOT FUNCTIONING PROPERLY	CONTACT STELLAR CUSTOMER SERVICE FOR SUPPORT
CYLINDER DRIFTS OUTWARD OR DOWNWARD	COUNTER BALANCE VALVES ARE NOT FUNCTIONING PROPERLY	CONTACT STELLAR CUSTOMER SERVICE FOR SUPPORT
	AIR IN HYDRAULIC SYSTEM	FULLY CYCLE THE CYLINDER BOTH DIRECTIONS (BLOW PAST RELIEF) TO REMOVE AIR FROM SYSTEM
	LEAK IN HYDRAULIC SYSTEM	VISUALLY INSPECT. REPAIR/REPLACE IF NECESSARY
	DEFECTIVE CYLINDER PISTON SEALS	VISUALLY INSPECT. REPAIR/REPLACE IF NECESSARY
	EXCESSIVE LOAD INDUCED THROUGH CRANE	VERIFY CAPACITY CHART
	VALVE BANK NOT FUNCTIONING PROPERLY	VERIFY OIL QUALITY
	DAMAGED CYLINDER	VISUALLY INSPECT. REPLACE IF NECESSARY

PROBLEM	POSSIBLE CAUSE	POSSIBLE SOLUTION
SINGLE CRANE FUNCTION ILL NOT OPERATE (WILL NOT PRESSURIZE)	VALVE SECTION SHUTTLE BALL IS NOT RELEASING	LOCATE A DIFFERENT VALVE SECTION FURTHER DOWN STREAM FROM THE VALVE SECTION THAT IS NOT FUNCTIONING. NOTE: USE A FUNCTION OTHER THAN ANY ROTATION SECTIONS SUCH AS CRANE ROTATION, TIREMAN ROTATION, OR PAD ROTATION. OPERATE THE VALVE SECTION OR CRANE FUNCTION FURTHER DOWN STREAM FROM THE FAULTY VALVE SECTION. EXTEND THE CYLINDER OR CYLINDERS UNTIL FULL EXTENSION IS ACHIEVED AND HOLD. WHILE HOLDING THAT FUNCTION, OPERATE THE FAULTY VALVE SECTION FUNCTION, THEN QUICKLY RELEASE THE HANDLE ASSEMBLY OF THE VALVE SECTION THAT WAS BEING HELD. BY PRESSURIZING THE THE FUNCTION FURTHER DOWN STREAM AND QUICKLY RELEASING THE HANDLE, THE BACK PRESSURE SHOULD RELEASE THE SHUTTLE BALL ON THE FAULTY VALVE SECTION. THIS MAY NOT WORK THE FIRST TIME SO REPEAT THE ABOVE PROCEDURE UNTIL THE FAULTY FUNCTION OPERATES PROPERLY
VIBRATIONS AND JERKING IN HYDRAULIC CYLINDERS	AIR IN CYLINDER	FULLY CYCLE THE CYLINDER BOTH DIRECTIONS (BLOW PAST RELIEF) TO REMOVE AIR FROM SYSTEM
	THE TEMPERATURE OF THE HYDRAULIC OIL IS TOO LOW	PERFORM MANEUVERS WITHOUT LOADS FOR SEVERAL MINUTES TO WARM UP THE OIL
	LACK OF OIL IN RESERVOIR	ADD HYDRAULIC OIL
	COUNTER BALANCE VALVES ARE NOT FUNCTIONING PROPERLY	CONTACT STELLAR CUSTOMER SERVICE FOR SUPPORT
CRANE ROTATION IS ABNORMAL DURING OPERATION	INADEQUATE BEARING LUBRICATION	LUBRICATE GEAR BEARING/GEAR BOX
	THE TRUCK IS NOT ON A LEVEL SURFACE	LEVEL THE TRUCK USING STABILIZERS
	ROTATION BEARING IS WORN	REPLACE WITH NEW BEARING KIT
	ROTATION MOTOR WORN	REPLACE ROTATION MOTOR
	GEAR BEARING WORN/ MISSING TEETH.	REPLACE WITH NEW BEARING KIT

PROBLEM	POSSIBLE CAUSE	POSSIBLE SOLUTION
THE CRANE DOES NOT LIFT THE LOADS ON THE LOAD CHART	INCORRECT SYSTEM PRESSURE	INCORRECT SYSTEM PRESSURE
	CRANE IS NOT RECEIVING PROPER HYDRAULIC PRESSURE	CHECK HYDRAULIC RESERVOIR FLUID LEVEL
		ENSURE DUMP VALVE IS OPERATING PROPERLY
		VERIFY HYDRAULIC PUMP IS PRODUCING PROPER PRESSURE
THE CRANE DOES NOT LIFT THE LOADS ON THE LOAD CHART	CRANE IS NOT RECEIVING PROPER YDRAULIC FLOW	CHECK HYDRAULIC RESERVOIR FLUID LEVEL
		ENSURE DUMP VALVE IS OPERATING PROPERLY
		VERIFY HYDRAULIC PUMP IS PRODUCING PROPER FLOW
		ENSURE HYDRAULIC OIL IS AT THE PROPER OPERATING TEMPERATURE
NOISE COMING FROM ARTICULATION POINTS	BUSHINGS ARE WORN	REPLACE BUSHINGS
	INADEQUATE LUBRICATION	LUBRICATE BUSHINGS
	DAMAGED STRUCTURE	INSPECT AND REPAIR/REPLACE AS NEEDED
	BROKEN/WORN PIN	REPLACE PIN
STABILIZERS FAIL TO OPERATE	REMOTE/MANUAL SWITCH IS IN THE REMOTE POSITION	TOGGLE SWITCH TO THE MANUAL POSITION
	REMOTE/MANUAL SWITCH IS MALFUNCTIONING.	INSPECT AND REPAIR/REPLACE AS NEEDED
	PANIC BAR/E-STOP IS ENGAGED (MODELS 9000/13500)	RELEASE PANIC BAR/E-STOP

Manual Operation

If the remote control malfunctions, follow these steps to operate the crane manually:

1. Activate Flow Control. Turn the override screw on proportional flow control counter-clockwise. Full adjustment is between three and five turns.

2. Operate Solenoids. Using the identification decal as a guide, slide the knurled sleeve out and then push or pull to operate the desired function. Be sure the sleeve is in the center, locked, position before returning to remote operation.

3. Deactivate Flow Control. Turn the override screw clockwise until stopped. Full adjustment is between 3 and 5 turns.

4. Return the valve bank manual overrides to the neutral position.

⚠ WARNING Failure to return the valve bank manual overrides to the neutral position can result in unexpected crane movement.

5. Have the unit serviced immediately to restore remote control functionality.

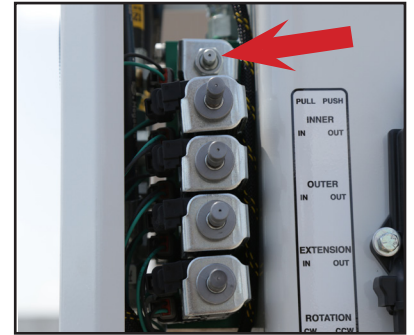

Flow Control Valve

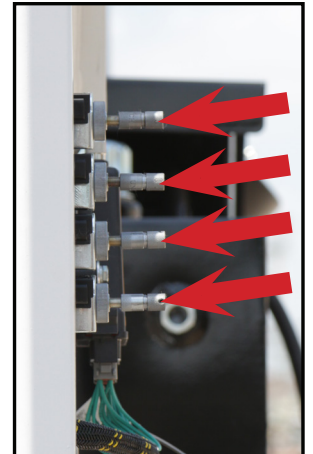

Solenoids



Subject to Change without Notification.
© 2024 Stellar Industries, Inc.