

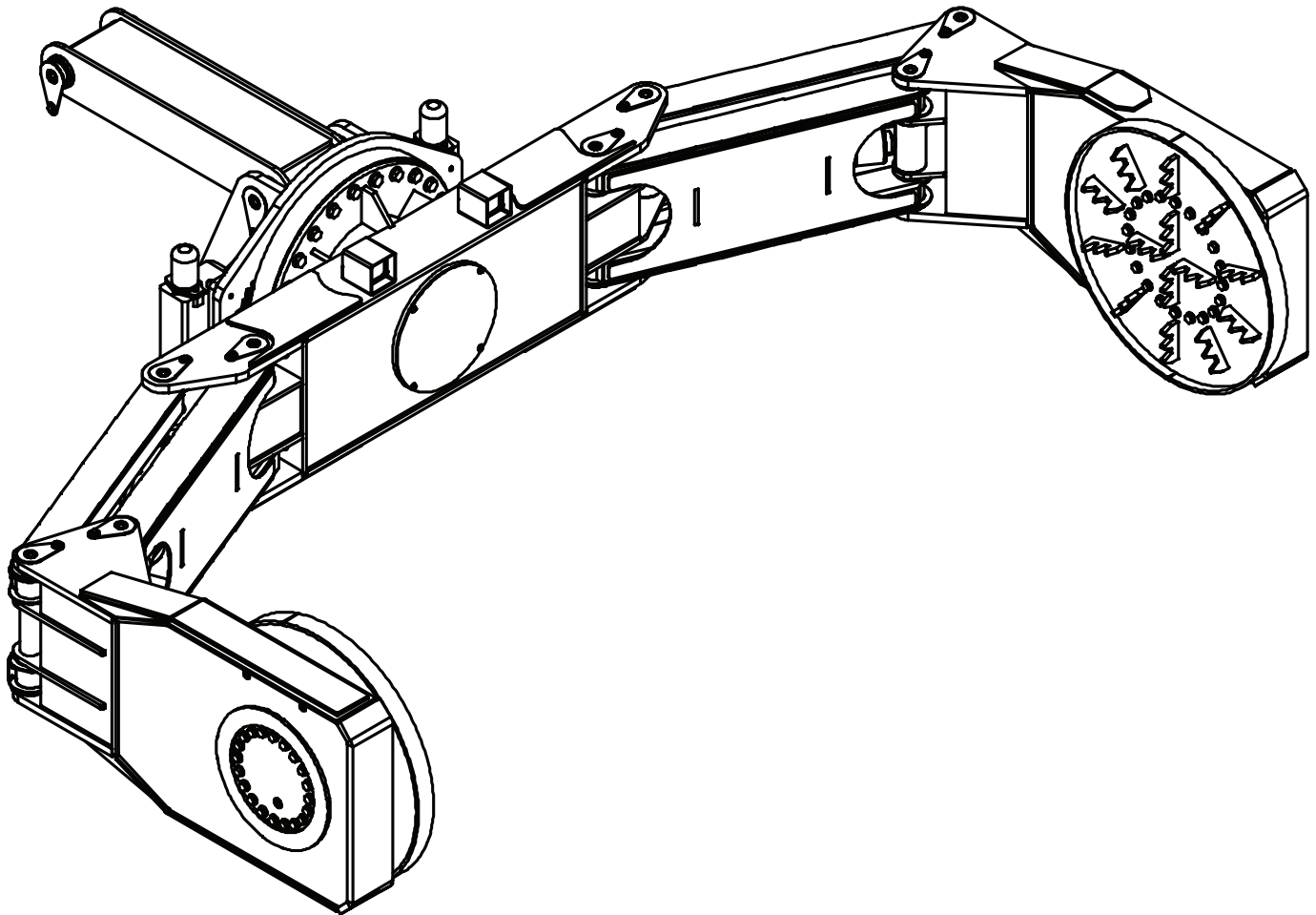

TireMan 20165 Owner's Manual

Installation • Assembly Drawings • Parts



Notice: A copy of this manual must remain with the equipment at all times.
For a printable download copy, please visit: www.stellarindustries.com

Stellar Industries, Inc.

190 State Street

PO Box 169

Garner, IA 50438

800-321-3741

Fax: 641-923-2811

www.stellarindustries.com

Subject to Change without Notification.
© 2022 Stellar Industries, Inc.

Rev 1
PN 90385

Model TM20165 Manual Revisions

Date of Revision	Section Revised	Description of Revision
2/17/16	Hydraulics and Assembly	Updated Hydraulic and Assembly Drawings

⚠ WARNING

Operating, maintaining, and servicing a Stellar product may expose you to chemicals including, but not limited to, engine exhaust, carbon monoxide, phthalates, and lead. These chemicals are known to the State of California to cause cancer and birth defects (or other reproductive harm). To keep your exposure to a minimum, be sure to avoid breathing exhaust and service your Stellar product in a well-ventilated area while wearing gloves or washing your hands frequently. For more information, go to www.P65Warnings.ca.gov/passenger-vehicle.

Table of Contents

Introduction.....	iv
Model TM20165 Specifications.....	1
TM20165 Dimensional Layout	2
General Installation	3
Installer Notice	3
Torque Data Chart	4
Hydraulic Installation	5
Face Seal/O-Ring Size Chart.....	6
Hydraulic Kit - PN 81761 Part 1	7
Hydraulic Kit - PN 81761 Part 2	8
Hydraulic Kit - PN 81761 Part 3	9
Hydraulic Installation Drawing - PN 82658	10
Hydraulic Schematic - PN 81761	11
TireMan Hydraulic Kit - PN 65365.....	12
Cooler Wiring	13
PTO Schematic	14
24V Converter Wiring	15
Decal Placement - PN 77565	16
TM20165 Assembly Standard - PN 63528	17
TM20165 Assembly w/Fallback Protection - PN 76685	18
Crane Assembly - PN 81760 Part 1.....	19
Crane Assembly - PN 81760 Part 2.....	20
Crane Assembly - PN 81760 Part 3.....	21
Crane Assembly - PN 81760 Part 4.....	22
Mounting Kit Subframe Assembly - Part 1	23
Mounting Kit Subframe Assembly - Part 2.....	24
Crane Base Stabilizer Assembly - PN 65107	25
Crane Base Stabilizer Cylinder Assembly - PN 64367	26
Non-Crane Base Stabilizer Assembly - PN 64262.....	27
Non-Crane Base Stabilizer Extension Cylinder Assembly - PN 64367	28
Reservoir Assembly - PN 86517	29

Introduction

A copy of this manual is provided with every tire manipulator and can be found in the hard plastic manual case that is installed on the chassis. A copy of this manual shall remain with the tire manipulator at all times.

Throughout the manual, three signal words will be used to bring attention to important items:

NOTICE

A NOTICE signal word indicates a practice not related to physical injury.

⚠ WARNING

A WARNING signal word indicates a hazardous situation which, if not avoided, could result in death or serious injury.

⚠ DANGER

A DANGER signal word indicates a hazardous situation which, if not avoided, will result in death or serious injury.

Information contained within this manual does not cover operation, maintenance, or troubleshooting. Please refer to the Large OTR Crane Manual for details on these items.

This manual is not binding. Stellar Industries, Inc. reserves the right to change, at any time, any or all of the items, components, and parts deemed necessary for product improvement or commercial/production purposes. This right is kept with no requirement or obligation for immediate mandatory updating of this manual.

In closing:

If more information is required or technical assistance is needed, or if you feel that any part of this manual is unclear or incorrect, please contact the Stellar Customer Service Department by phone at 800-321-3741 or email at service@stellarindustries.com.

**For Technical Questions, Information, Parts, or Warranty, Call Toll-Free at
800-321-3741**

Hours: Monday - Friday, 8:00 a.m. - 5:00 p.m. CST

Or email at the following addresses:

Technical Questions, and Information

service@stellarindustries.com

Order Parts

parts@stellarindustries.com

Warranty Information

warranty@stellarindustries.com

Model TM20165 Specifications

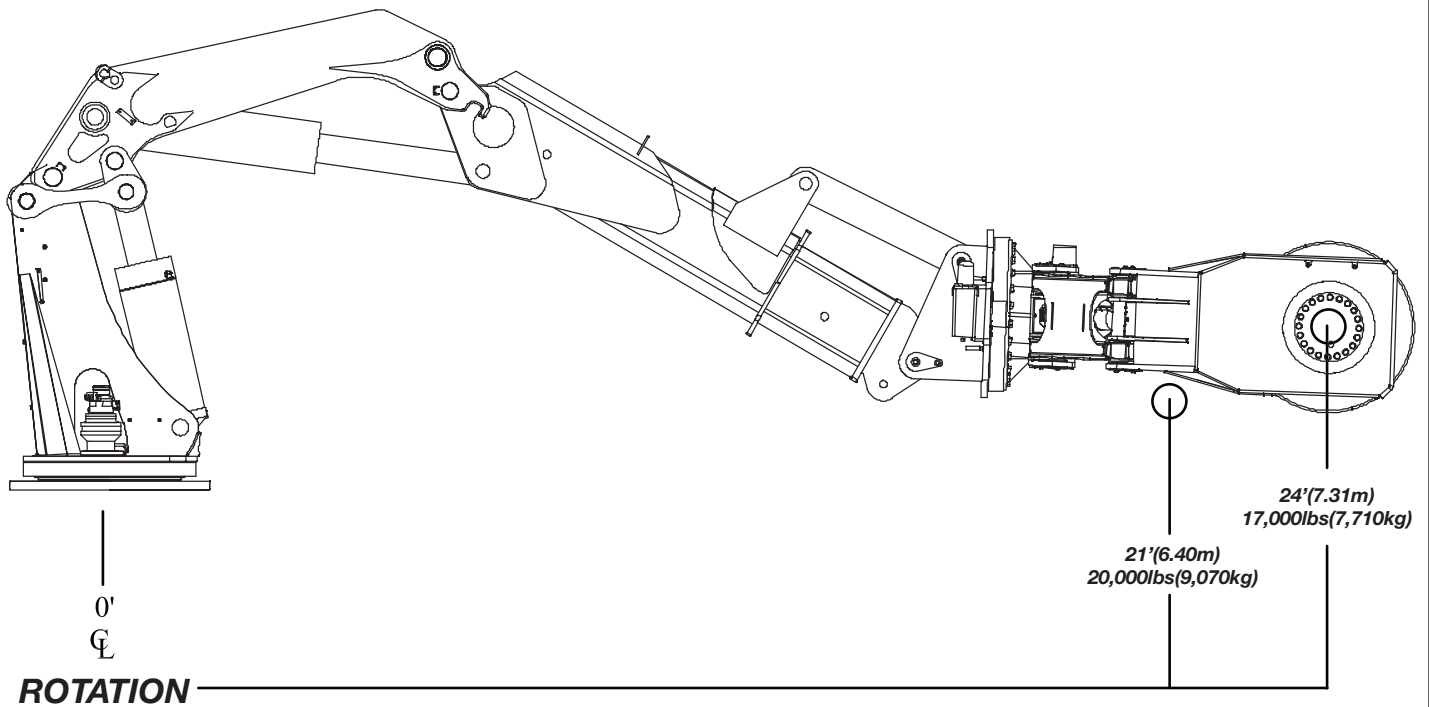

Capacity:	20,000 lbs @ 21' (9,070 kg @ 6.4 m)
Clamping Span:	43" to 164" (110 cm to 417 cm)
Clamp Cylinders:	5" (12.7 cm) bore with pilot operated check valves
Tilt Cylinder:	Provided by crane extension boom
Body Rotation:	320° power
Rotation System:	Worm gear
Clamping Pad Rotation:	Continuous 360° power
TireMan Tilt:	+74° to -27.5°
System Pressure:	5000 PSI (350 bar)
Hydraulic Flow:	26-32 GPM (100-120 L/min)
Hydraulic Controls:	Incorporated with the crane controls
Approximate Shipping Weight:	10,700 lbs (4,854 kg)

TM20165 Dimensional Layout

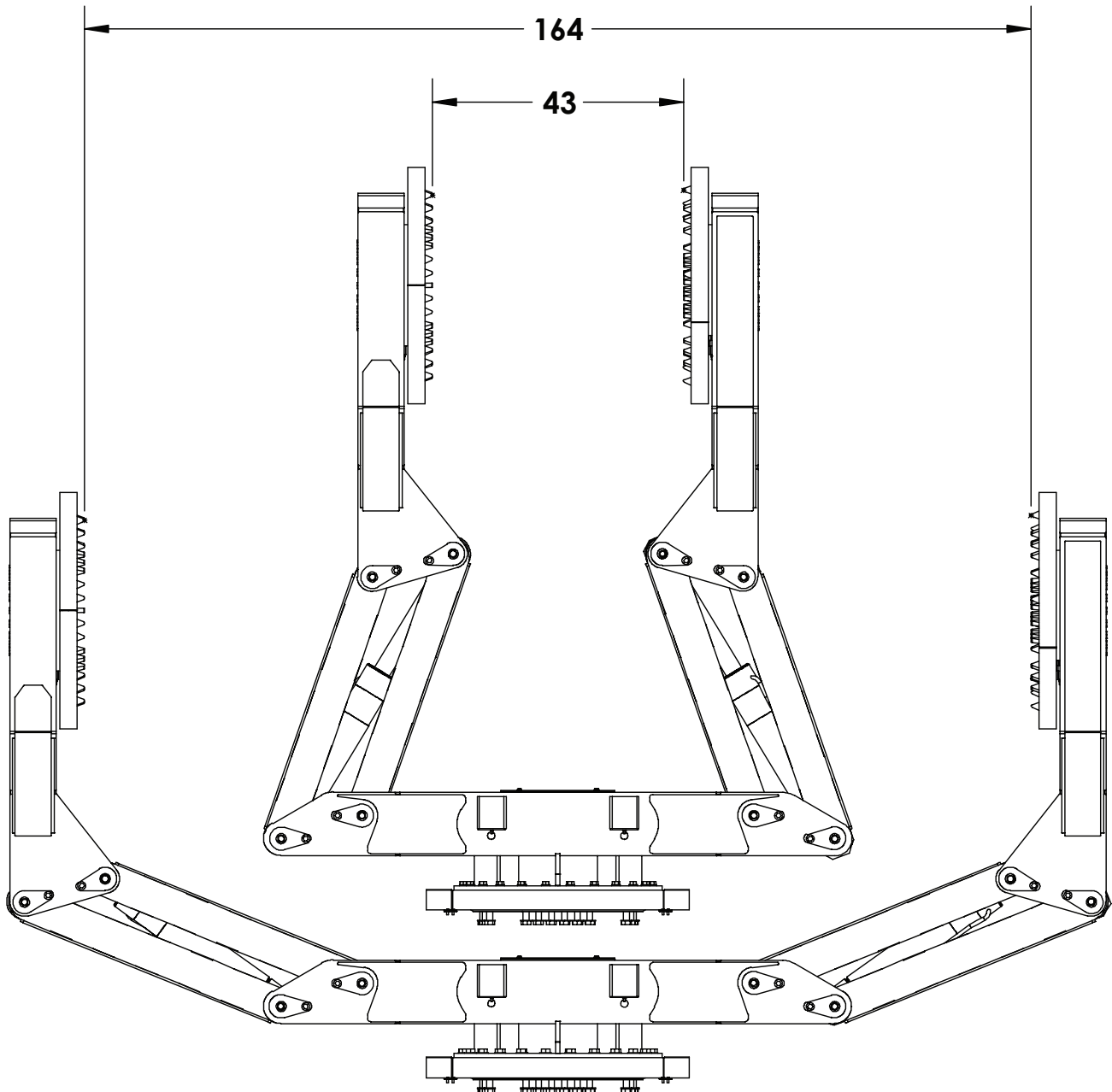

General Installation

This chapter is designed to serve as a general guide for the installation of a Stellar TM20165 on a Stellar Service Crane. Each installation is considered unique so certain portions of this chapter may or may not apply to your direct application. If a question should arise during the installation process, please contact Stellar Customer Service at (800) 321 3741.

This crane is designed for use with a Stellar Service Crane installed on a vehicle that meets the minimum chassis requirements of the crane. It is the installer's responsibility to assure that the unit is mounted on a platform that will support the maximum crane rating of this crane.

⚠ WARNING Do not install this crane/manipulator on a body not capable of handling the loads imposed on it. Failure to do so may result in serious injury or death.

Installer Notice

According to Federal Law (49 cfr part 571), each final-stage manufacturer shall complete the vehicle in such a manner that it conforms to the standards in effect on the date of manufacture of the incomplete vehicle, the date of final completion, or a date between those two dates. This requirement shall, however, be superseded by any conflicting provisions of a standard that applies by its terms to vehicles manufactured in two or more stages.

Therefore, the installer of Stellar® Cranes and Bodies is considered one of the manufacturers of the vehicle. As such a manufacturer, the installer is responsible for compliance with all applicable federal and state regulations. They are required to certify that the vehicle is in compliance with the Federal Motor Vehicle Safety Standards and other regulations issued under the National Traffic and Motor Vehicle Safety Act.

Please reference the Code of Federal Regulations, title 49 - Transportation, Volume 5 (400-999), for further information, or visit <http://www.gpoaccess.gov/nara/index.html> for the full text of Code of Federal Regulations.

Torque Data Chart

When using the torque data in the chart, the following rules should be observed:

- Bolt manufacturer's particular specifications should be consulted when provided.
- Flat washers of equal strength must be used.
- All torque measurements are given in foot-pounds. To convert to inch-pounds, multiply by 12.
- Torque values specified are for bolts with residual oils or no special lubricants applied.
- Torque values for socket-head capscrews are the same as for Grade 8 capscrews.

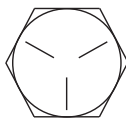
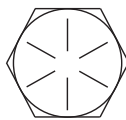
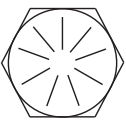
		GRADE 5		GRADE 8		GRADE 9
						
Size (DIA-TPI)	Bolt DIA (Inches)	Plain (Ft-Lb)	Plated (Ft-Lb)	Plain (Ft-Lb)	Plated (Ft-Lb)	Plated (Ft-Lb)
5/16-18	0.3125	17	13	25	18	22
3/8-16	0.3750	31	23	44	33	39
7/16-14	0.4375	49	37	70	52	63
1/2-13	0.5000	75	57	105	80	96
9/16-12	0.5625	110	82	155	115	139
5/8-11	0.6250	150	115	220	160	192
3/4-10	0.7500	265	200	375	280	340
7/8-9	0.8750	395	295	605	455	549
1-8	1.000	590	445	910	680	823
1 1/8-7	1.1250	795	595	1290	965	1167
1 1/4-7	1.2500	1120	840	1815	1360	1646
1 3/8-6	1.3750	1470	1100	2380	1780	2158
1 1/2-6	1.500	1950	1460	3160	2370	2865

- **NOTICE** Do not use these values if a different torque value or tightening procedure is given for a specific application. Torque values listed are for general use only. Check tightness of fasteners periodically.
- Shear bolts are designed to fail under predetermined loads. Always replace shear bolts with identical grade.
- Fasteners should be replaced with the same or higher grade. If higher grade fasteners are used, these should only be tightened to the strength of the original.
- Tighten plastic insert or crimped steel-type lock nuts to approximately 110 percent of the dry torque values shown in the chart below, applied to the nut, not to the bolt head. Tighten toothed or serrated-type lock nuts to the full torque value. *Note: "Lubricated" means coated with a lubricant such as engine oil, or fasteners with phosphate and oil coatings. "Dry" means plain or zinc plated without lubrication. Tighten lubricated bolts to approximately 80% of dry bolts.*

Hydraulic Installation

Never modify or alter any of the equipment, whether mechanical, electrical, or hydraulic, without Stellar Industries' approval.

⚠ WARNING Do not touch or grab any hoses that could be under pressure. Release system pressure before attempting to make adjustments or repairs.

Do not attempt service or repair when PTO is engaged.

Disassemble and assemble hydraulic components on a clean surface.

Clean all metal parts in a nonflammable cleaning fluid. Then lubricate all components to aid in assembly.

⚠ WARNING Hydraulic fluid expands when heated. This raises the pressure in an unventilated tank. Release the tank pressure before removing the cap completely. Failure to do so may cause the oil to shoot out of the tank very rapidly and cause severe burns.

⚠ WARNING Do not rely on the hydraulic fluid to support the boom or crane. If hydraulic fluid escapes, the boom or crane can fall immediately. Make sure the ground or blocking is supporting the boom before performing any maintenance or repair.

NOTICE Contaminants in a hydraulic system affect operation and will result in serious damage to the system components. Dirty hydraulic systems are a major cause of component failures.

If evidence of foreign particles is found in the hydraulic system, flush the system.

When installing metal hydraulic tubes, tighten all fittings finger tight. Then, in order, tighten the fittings at the rigid end, the adjustable end, and the mounting brackets. After tubes are mounted, install the hoses. Connect both ends of the hose with all fittings finger tight. Position the hose so it does not rub the machine or another hose and has a minimum of bending and twisting. Tighten fittings in both couplings.

Due to manufacturing methods, there is a natural curvature to a hydraulic hose. The hose should be installed so any bend is with this curvature.

Face Seal/O-Ring Size Chart

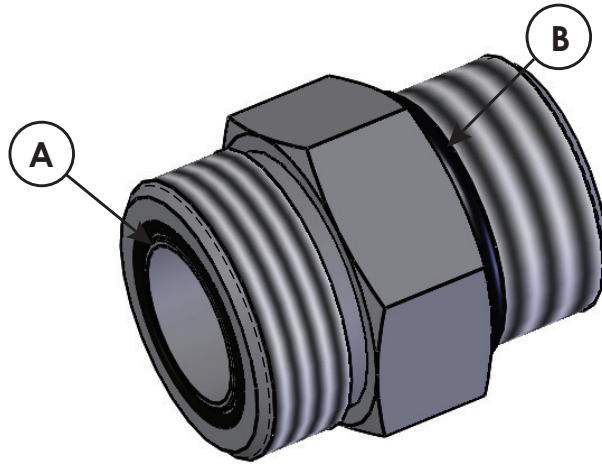

Hose Size	Fitting Size	Face Seal (A) Stellar® PN	O-ring Boss (B) Stellar® PN
1/4"	#4	C2027	D1245
3/8"	#6	C2028	D1246
1/2"	#8	C2029	D1247
5/8"	#10	32223	D1248
3/4"	#12	D1244	D1249
1"	#16		D1250

Hydraulic Kit - PN 81761 Part 1

PN 81761 - Part 1

ITEM	PART	DESCRIPTION	QTY.
1	C2142	FTG 12-12 MFS-MORB STRAIGHT	2
2	C2269	FTG 12-16 MFS-MORB STRAIGHT	1
3	59763	FTG 12-16 MFS-MBSPP STRAIGHT	2
4	31658	FTG 12-12 MFS-MBSPP STRAIGHT	3
5	c4903	FTG 12-12 MFS-FFSS 90	1
6	42053	FTG 12-12 MBSPP W/BS-FORB	3
7	51274	FTG 16-12 MFS-MAORB 90	1
8	65584	FTG 16-12 MFS-MBSPP 90	3
9	65580	FTG 16-16 MFS-MBSPP STRAIGHT	1
10	65582	FTG 12-12 MFS-MBSPP 90	1
11	67060	VALVE SHUTTLE VONBERG 65125-6T	1
12	30542	FTG 12-12-12 MAORB-FORB-FORB TEE	1
13	C2053	FTG 12-8 MORB-FORB STRAIGHT REDUCER	8
14	59959	FTG 16-16 MFS-MAORB 90	2
15	C5547	FTG 6-8 MFS-MAORB 90	1
16	C4227	FTG 8-12 MFS-MAORB 90	6
17	C2376	FTG 8-8 MFS-FFSS 90	6
18	65587	FTG 6-6 MFS-MBSPP STRAIGHT	1
19	12866	FTG 6-6 FFSS-MAORB 90	1
20	C0338	FTG 6-6 MFS-MAORB 90	2
21	65670	FTG 6-4 MFS-MBSPP STRAIGHT	1
22	10980	FTG 8-4 MORB-FORB STRAIGHT REDUCER	1
23	51817	FTG 4-4 MAORB-FORB 90	1
24	1554	FTG 8-8 MFS-MORB STRAIGHT	14
25	C5968	FTG 12-12 MFS-MAORB 90	2
26	39780	GAUGE OIL LF 2.5 0-6000 CBM SAE	1

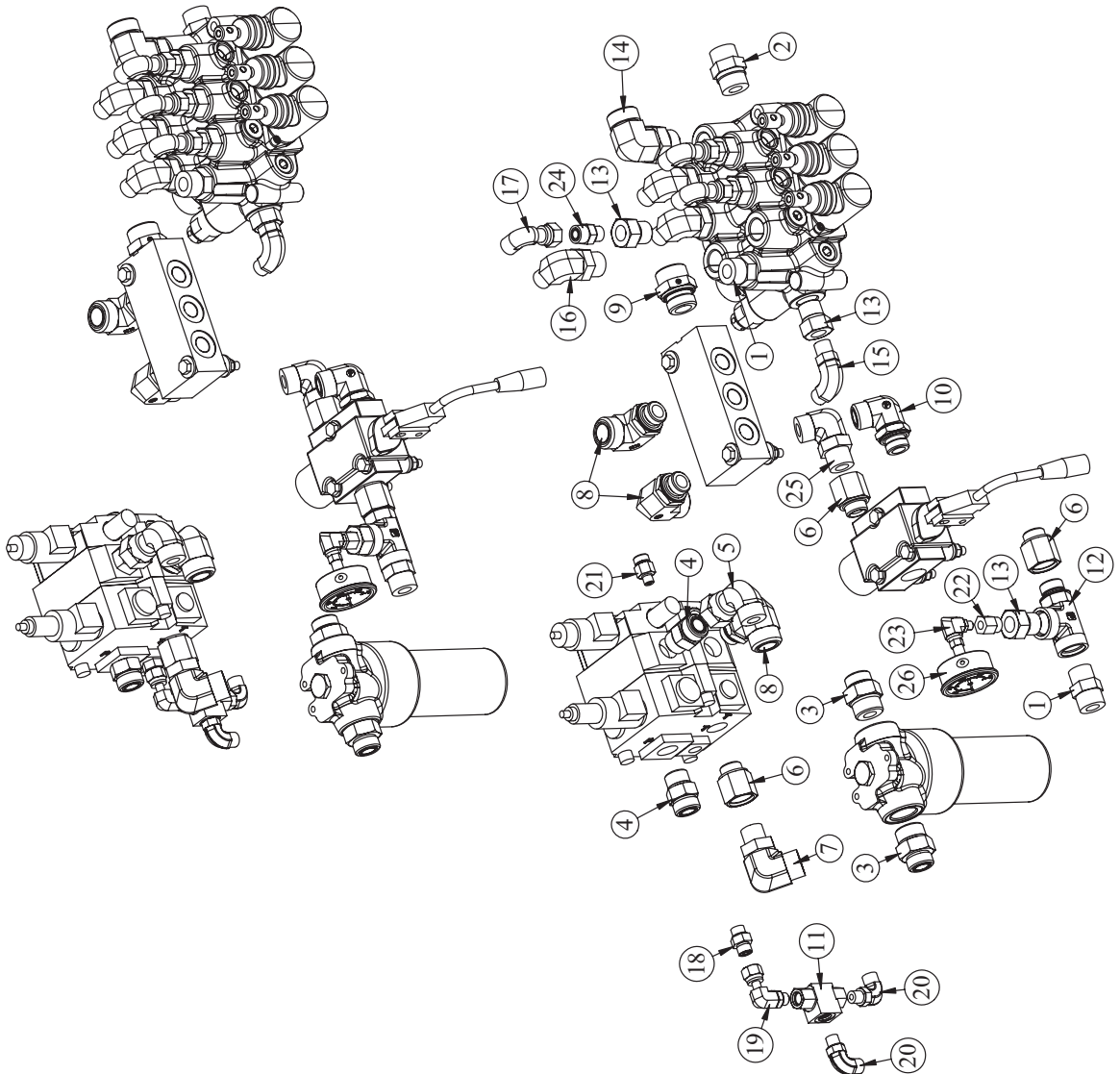

Hydraulic Kit - PN 81761 Part 2

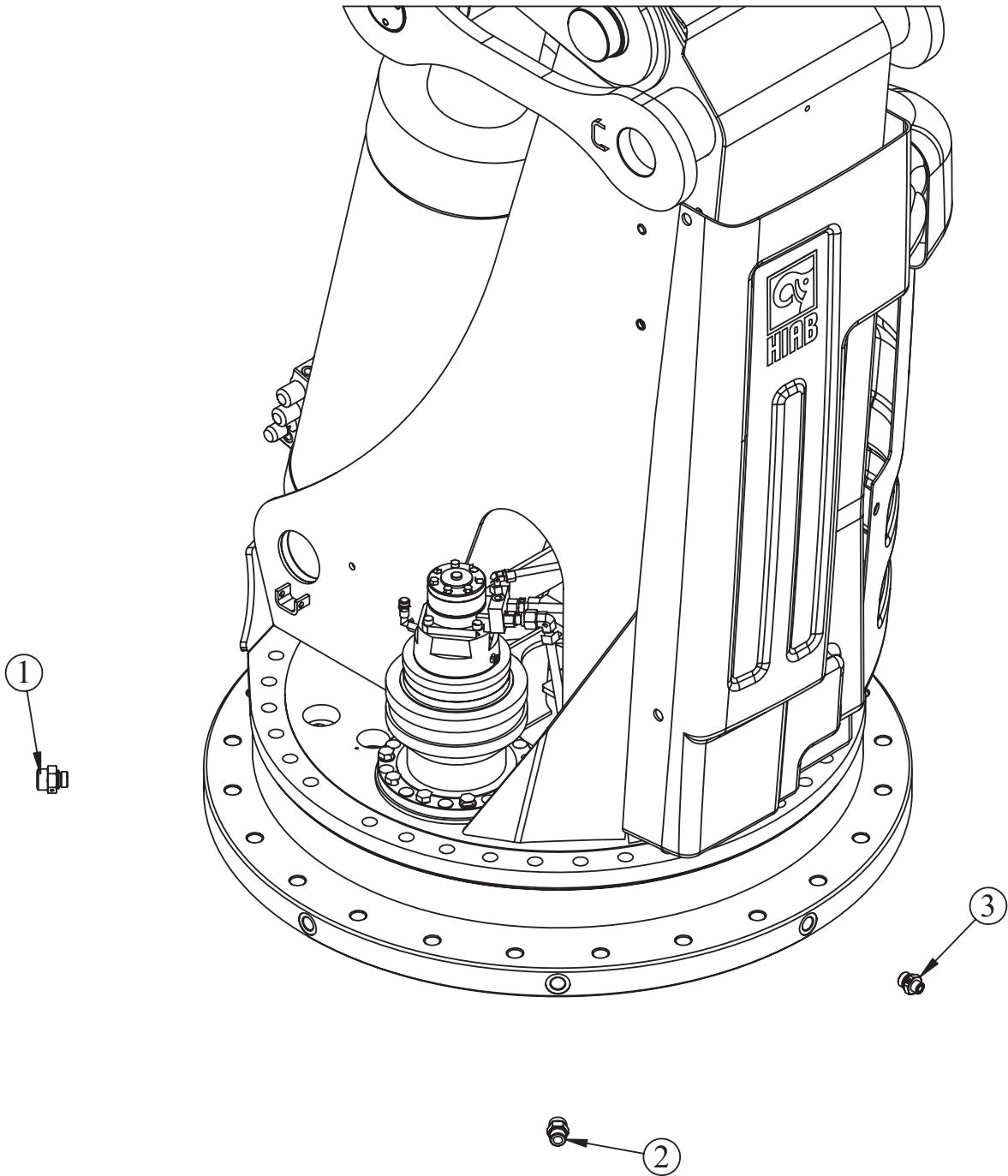

PN 81761 - Part 2

ITEM	PART	DESCRIPTION	QTY.
1	65579	FTG 16-12 MFS-MBSPP STRAIGHT	1
2	31658	FTG 12-12 MFS-MBSPP STRAIGHT	3
3	31659	FTG 8-12 MFS-MBSPP STRAIGHT	1

Hydraulic Kit - PN 81761 Part 3

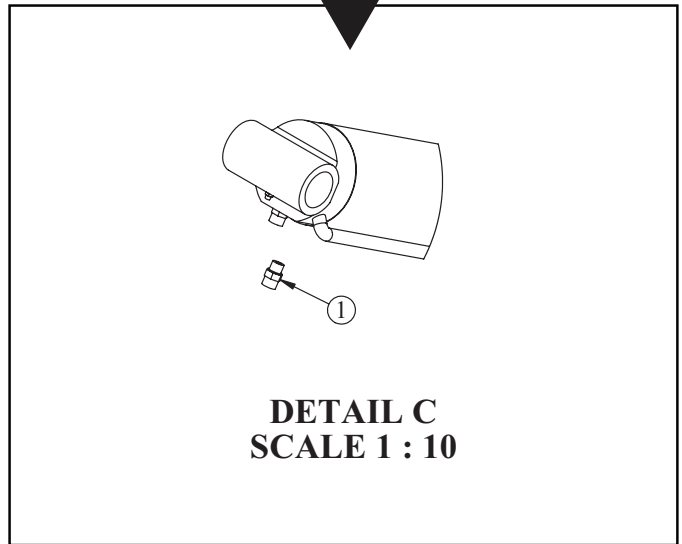
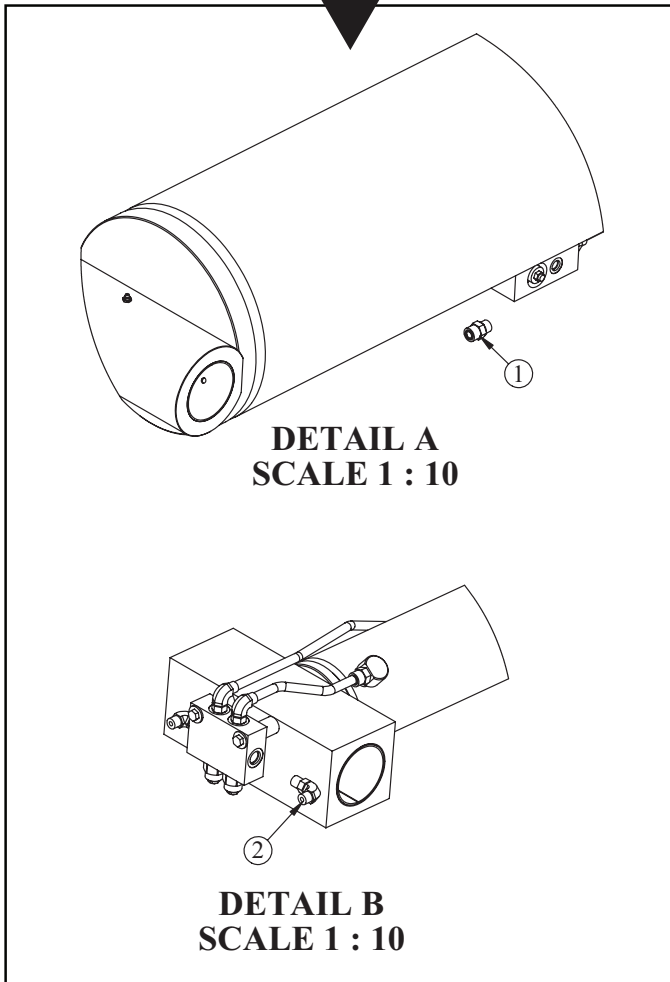
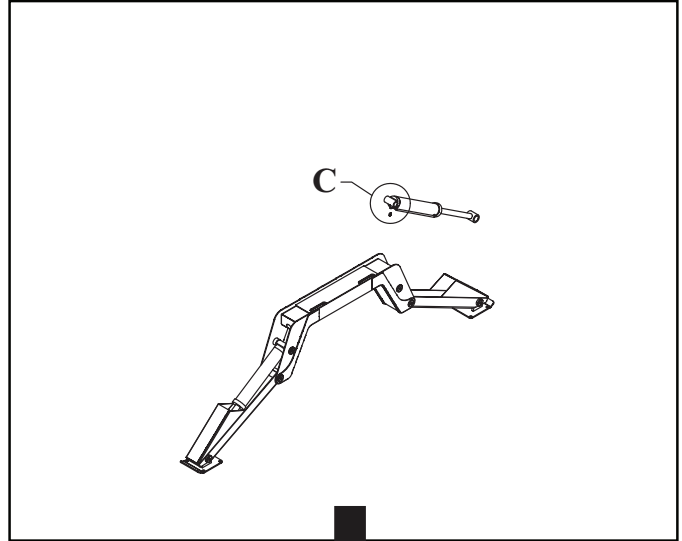
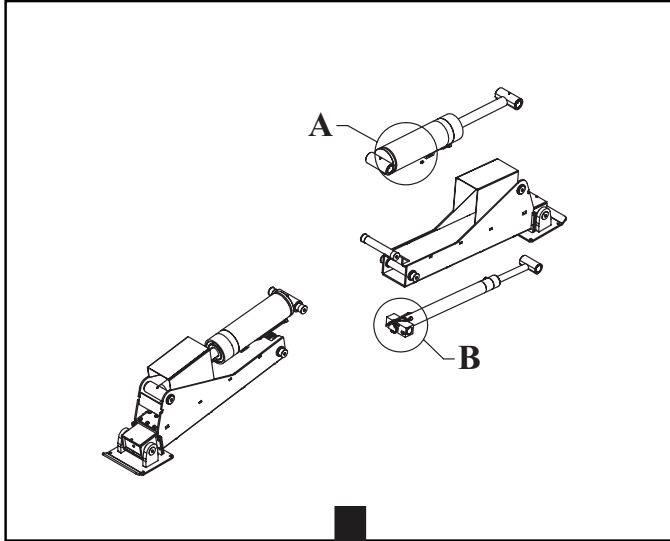

PN 81761 - Part 3

ITEM	PART	DESCRIPTION	QTY.
1	1554	FTG 8-8 MFS-MORB STRAIGHT	14
2	65663	FTG 8-8 MORB-MFS 90 SWIVEL	4

Hydraulic Installation Drawing - PN 82658

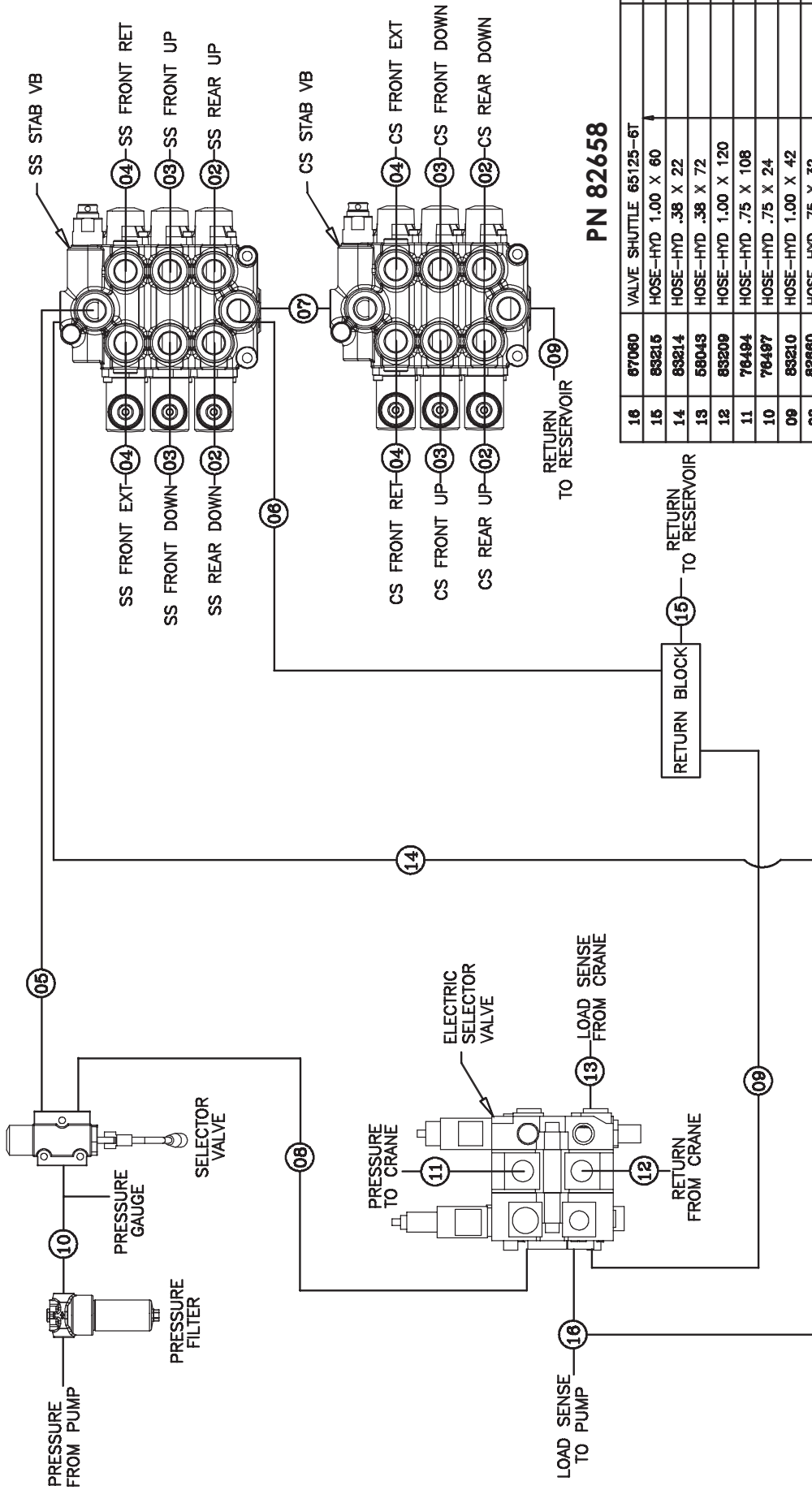

PN 82658

ITEM	PART No.	DESCRIPTION	QTY
16	67060	VALVE SHUTTLE 65125-6T	1
15	83216	HOSE-HYD 1.00 X 60	1ref
14	83214	HOSE-HYD .38 X 22	1ref
13	58043	HOSE-HYD .38 X 72	1ref
12	83209	HOSE-HYD 1.00 X 120	1ref
11	76494	HOSE-HYD .75 X 108	1ref
10	76497	HOSE-HYD .75 X 24	1ref
09	83210	HOSE-HYD 1.00 X 42	2ref
08	82860	HOSE-HYD .75 X 32	1ref
07	83213	HOSE-HYD .75 X 132	1ref
06	83208	HOSE-HYD 1.00 X 22	1ref
05	83207	HOSE-HYD .75 X 32	1ref
04	83212	HOSE-HYD .50 X 120	4ref
03	83211	HOSE-HYD .50 X 144	4ref
02	82859	HOSE-HYD .50 X 396	4ref
01	80908	HOSE KIT TMP20165 V2 (inci2-15)	1

Hydraulic Schematic - PN 81761

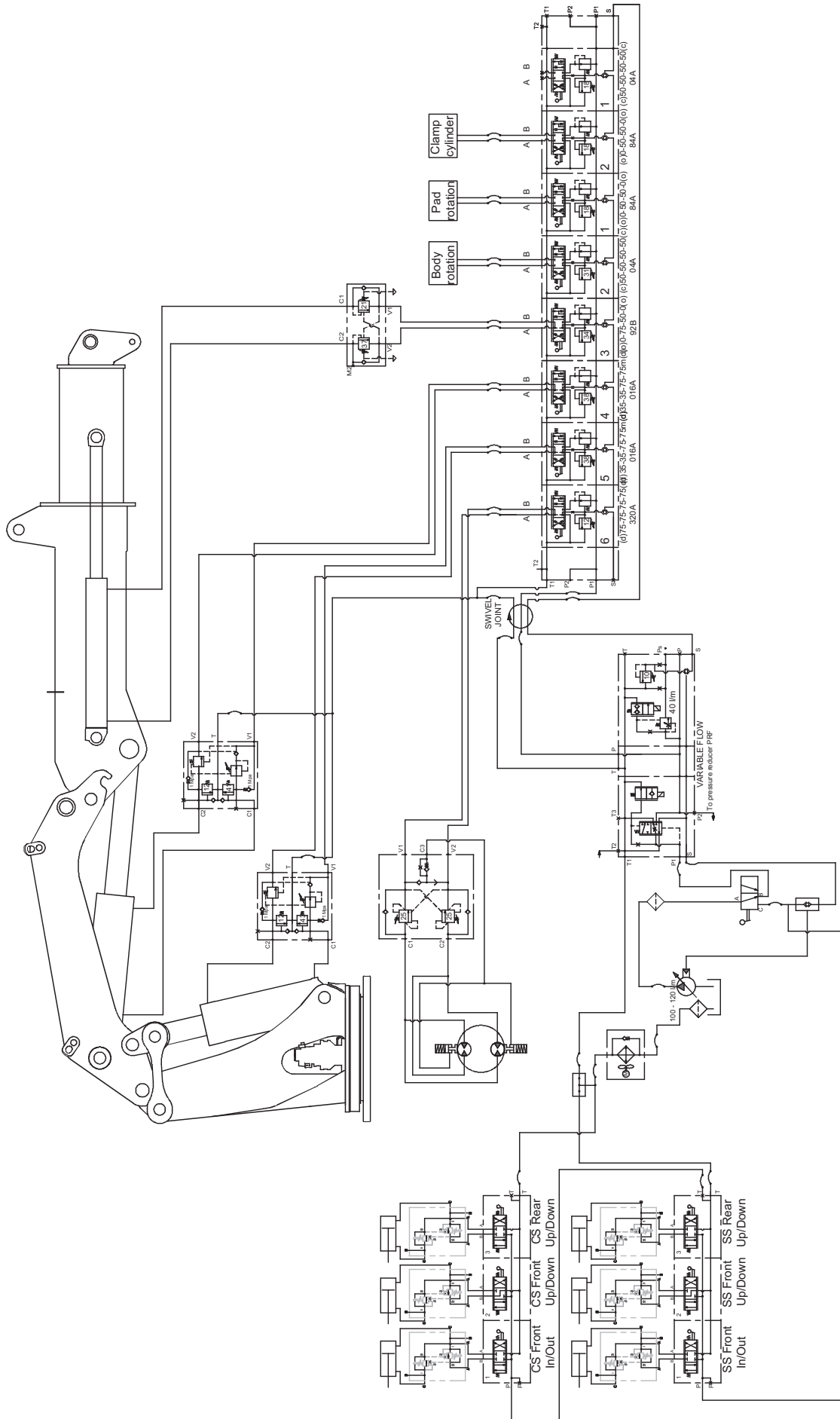

TireMan Hydraulic Kit - PN 65365

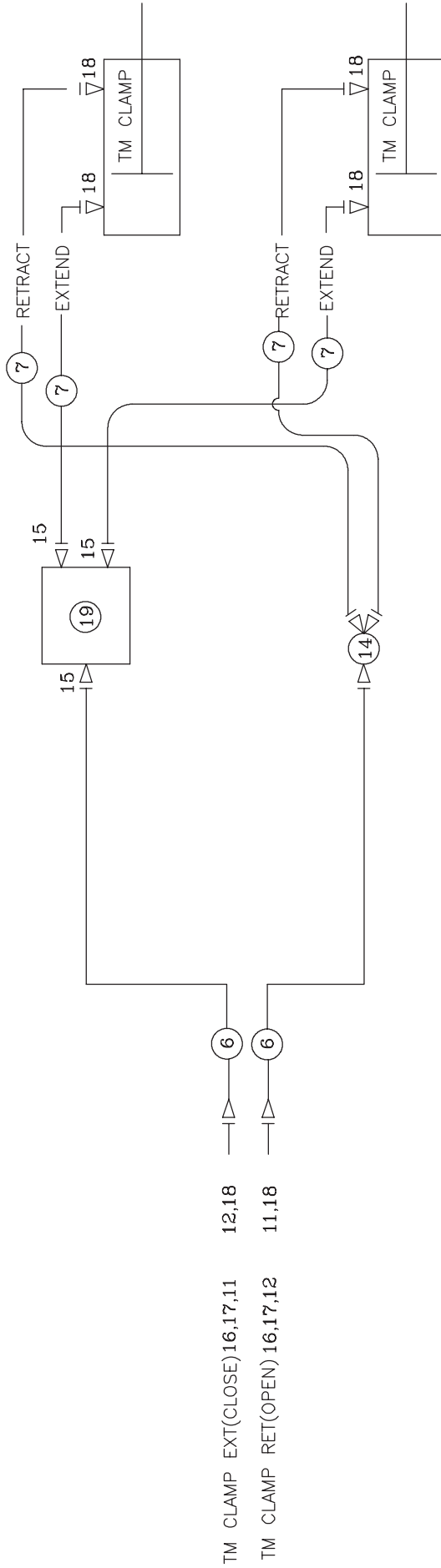

PN 65365

ITEM	PART No.	DESCRIPTION	QTY
19	65095	VALVE COMB DIV FD50-45-8TD-P-66	1
18	1554	FTG 8-8 MFS-MORB STRAIGHT	10
17	21400	FTG 8-8 MORB-FJS STRAIGHT	6
16	D1871	FTG 10-8 FJ-MJ STRAIGHT REDUCER	6
15	1556	FTG 8-8 MFS-MAORB 90	3
14	C2218	FTG 8-8-8 MFS-MFS-MFS TEE	1
13	C3643	FTG 8-10 MFS-MAORB 90	8
12	65573	QUICK COUPLER 2FFN12-12SAE-M	2
11	65572	QUICK COUPLER 2FFN12-12SAE-F	2
10	13557	QUICK COUPLER 2FFN38-12SAE-M	4
09	13556	QUICK COUPLER 2FFN38-12SAE-F	4
08			
07	78077	HOSE-HYD 0.50 X 60	4ref
06	31676	HOSE-HYD 0.50 X 120	2ref
05	78074	HOSE-HYD 0.50 X 52	1ref
04	78073	HOSE-HYD 0.50 X 124	2ref
03	78076	HOSE-HYD 0.50 X 310	1ref
02	78075	HOSE-HYD 0.50 X 272	2ref
01	65571	HOSE KIT, TM20165 (incl:2-7)	1

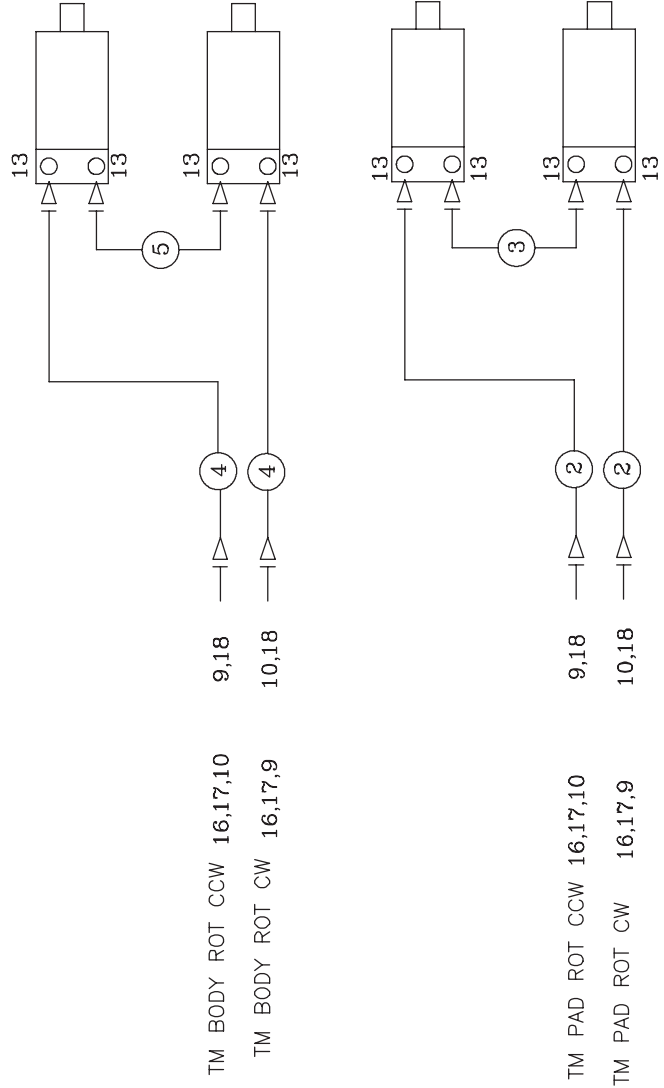

Cooler Wiring

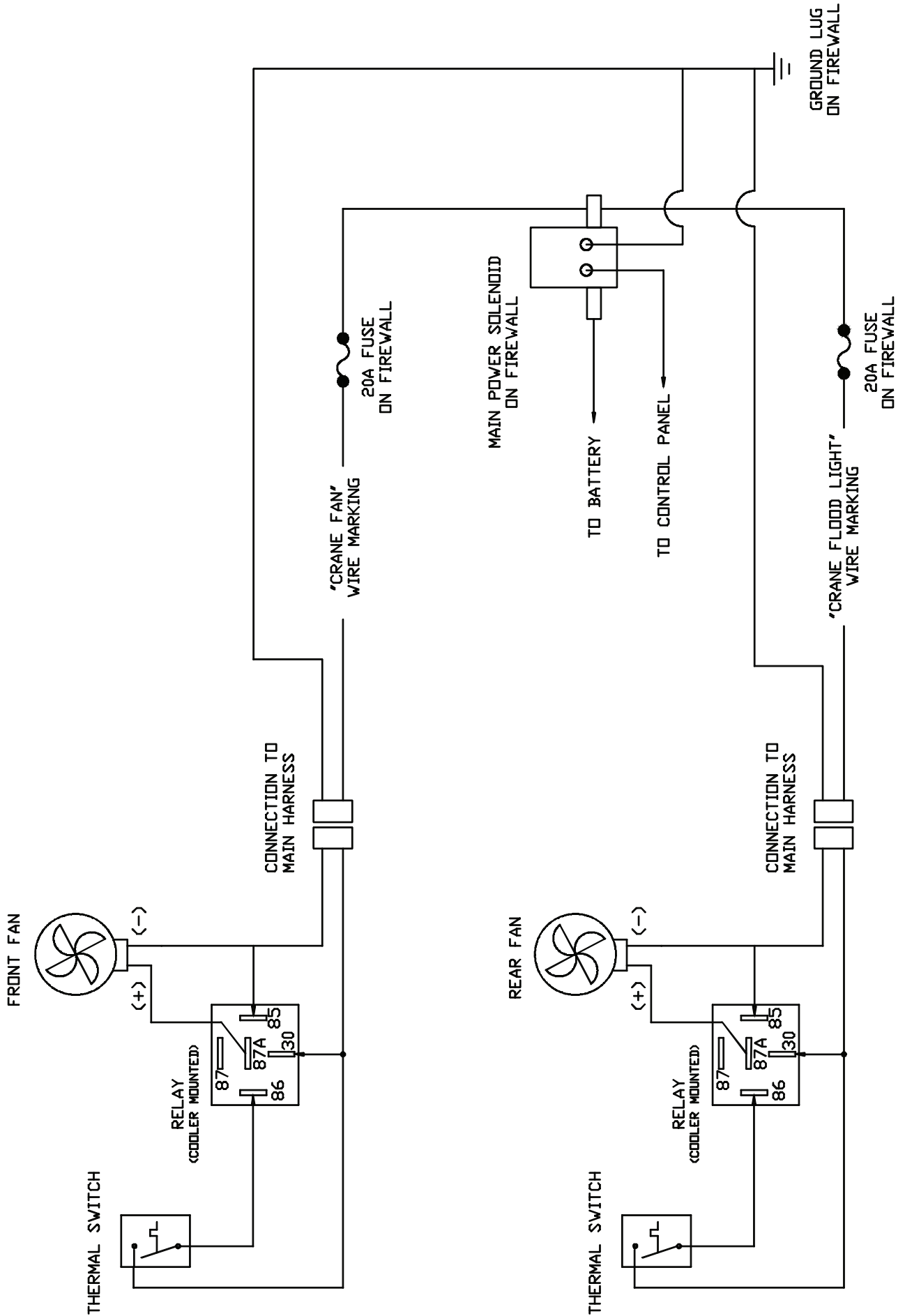

PTO Schematic

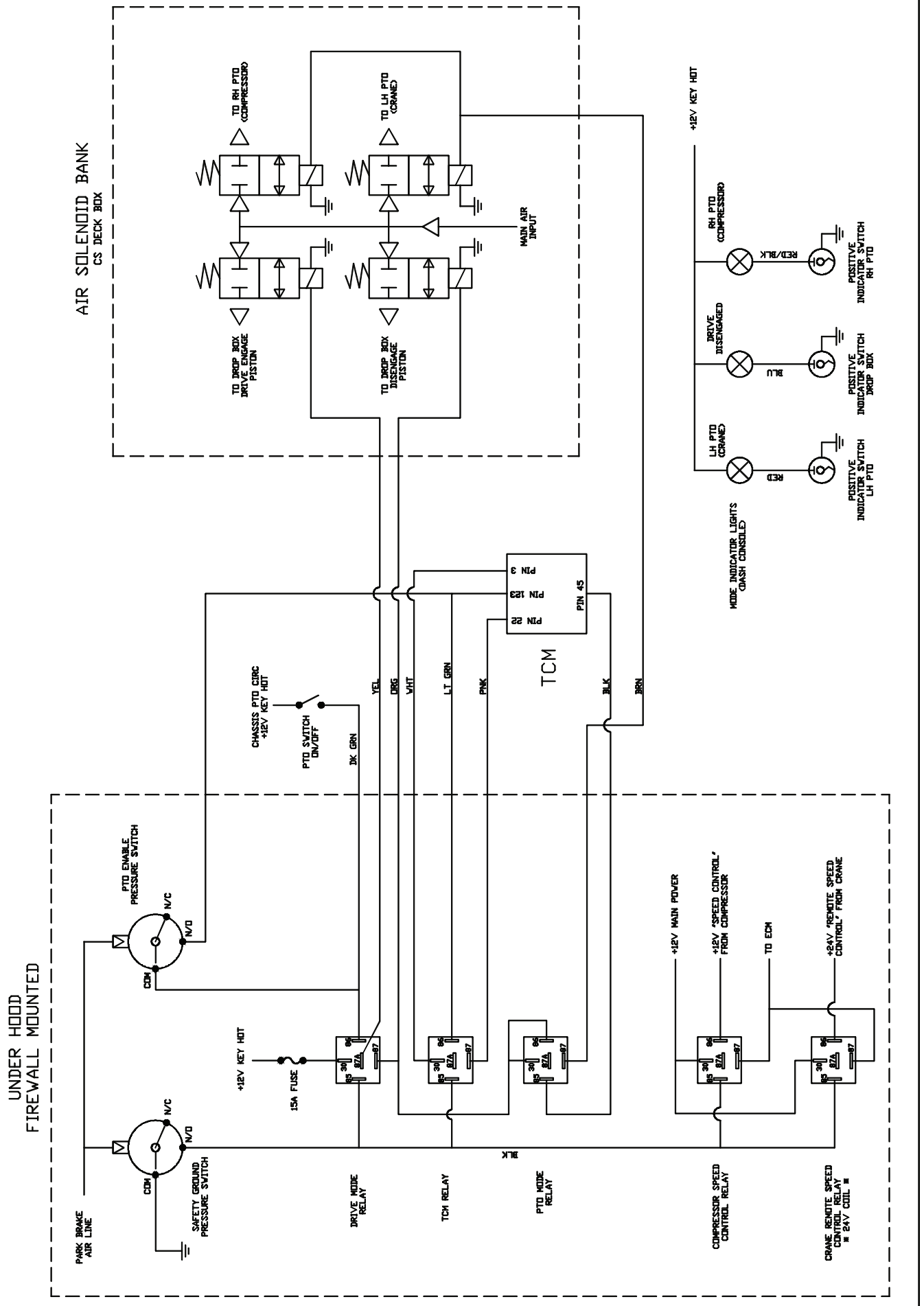

24V Converter Wiring

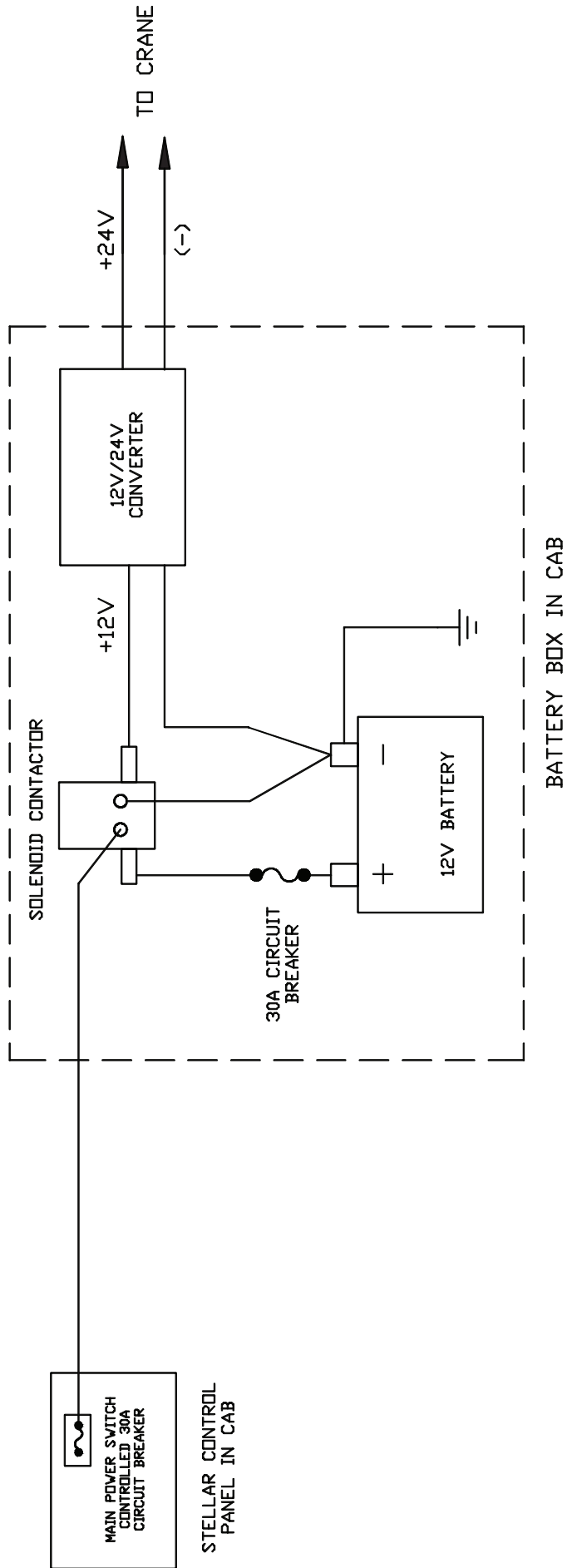

Decal Placement - PN 77565

Not Shown

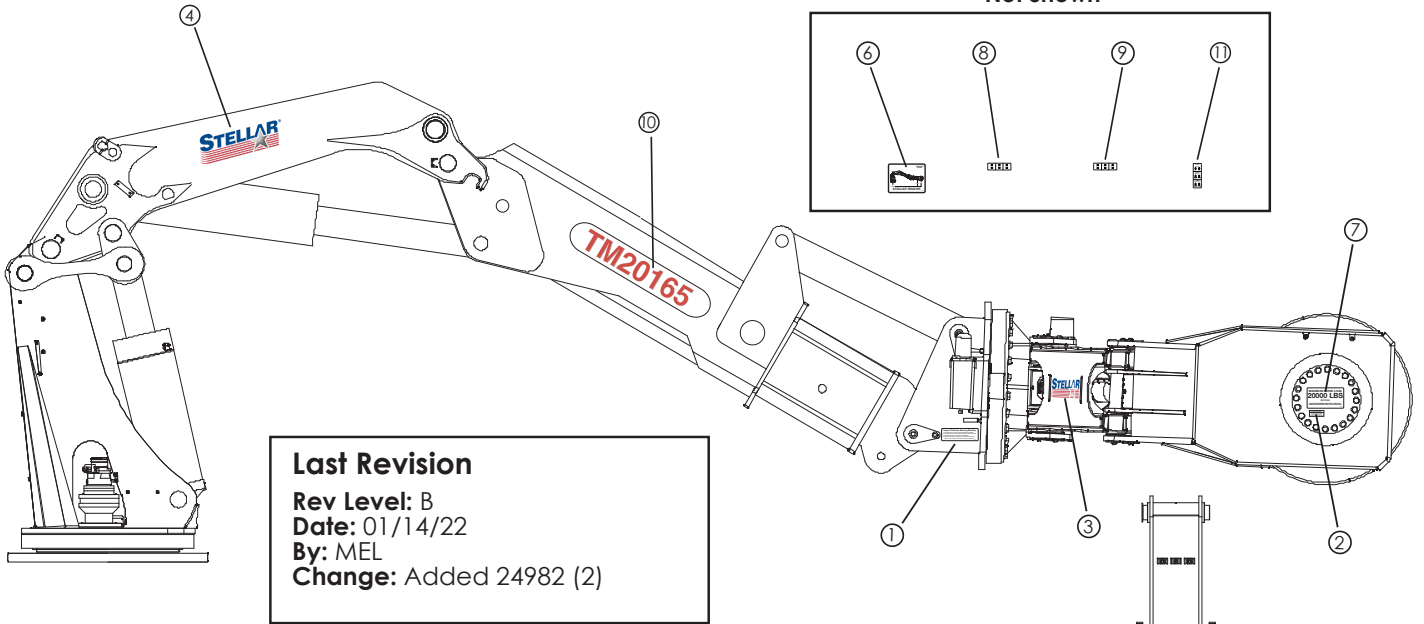

Last Revision
Rev Level: B
Date: 01/14/22
By: MEL
Change: Added 24982 (2)

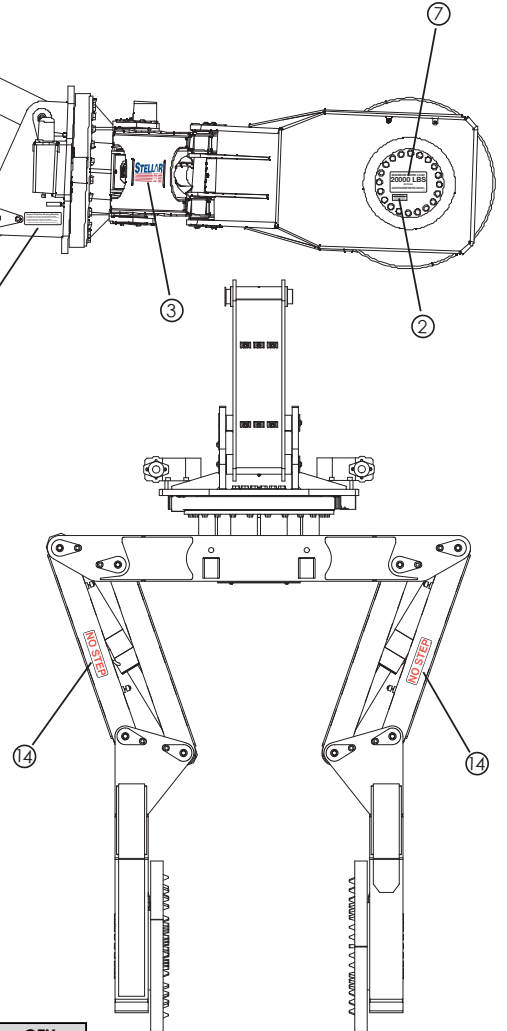
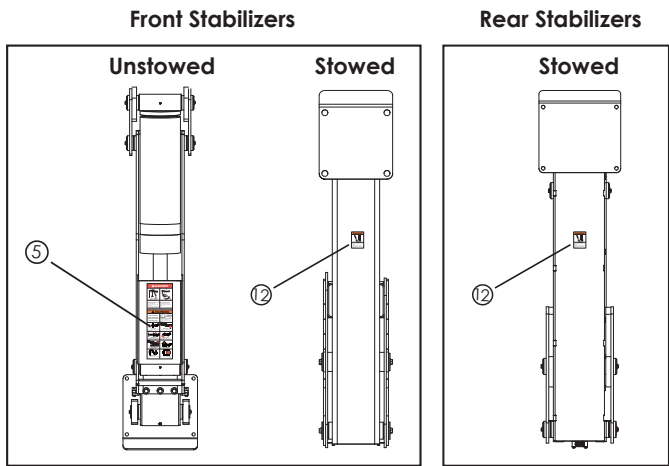

PN 77565

ITEM	PN	DESCRIPTION	LOCATION	QTY
1	22617	DECAL ROTATION BEARING	Rotation Bearing Base	1
2	22618	DECAL GREASE WEEKLY	Tire Man Arms - Both Sides	2
3	52681	DECAL STELLAR LOGO 6.00X16.50	TireMan Link - Both Sides	2
4	54589	DECAL STELLAR LOGO 8.00x22.25	Main Boom - Both Sides	2
5	54781	DECAL WARNING PLACARD	Front Stabilizer Leg - Both Sides	2
6	69749	DECAL CAPACITY TM20165	On body near control center - Not Shown	2
7	77562	DECAL RATED LOAD TM20165	Tire Man Arms - Both Sides	2
8	77563	DECAL STABILIZERS TM20165 SS	Near valve banks - Not Shown	1
9	77564	DECAL STABILIZERS TM20165 CS	Near valve banks - Not Shown	1
10	77566	DECAL IDENTIFICATION TM20165	Main Boom - Both Sides	2
11	77569	DECAL VB CONTROL TM20165	Near valve banks - Not Shown	1
12	C4795	DECAL WARNING STABILIZER	Front/Rear Stabilizer Legs - Both Sides	4
13	81771	DECAL TM20165 PUSH/PULL	Near Selector Valve - Not shown	1
14	24982	DECAL NO STEP 5.00X1.25	Tire Man Arms - Both Sides	2

For use with body:

ITEM	PN	DESCRIPTION	LOCATION	QTY
15	C4545	DECAL DANGER ELECTROCUTION	Four corners of the body.	4
16	C5910	DECAL STELLAR LOGO 3.75X9.00	Optional	1
17	C5911	DECAL STELLAR LOGO 1.65X4.50	Optional	3

TM20165 Assembly Standard - PN 63528

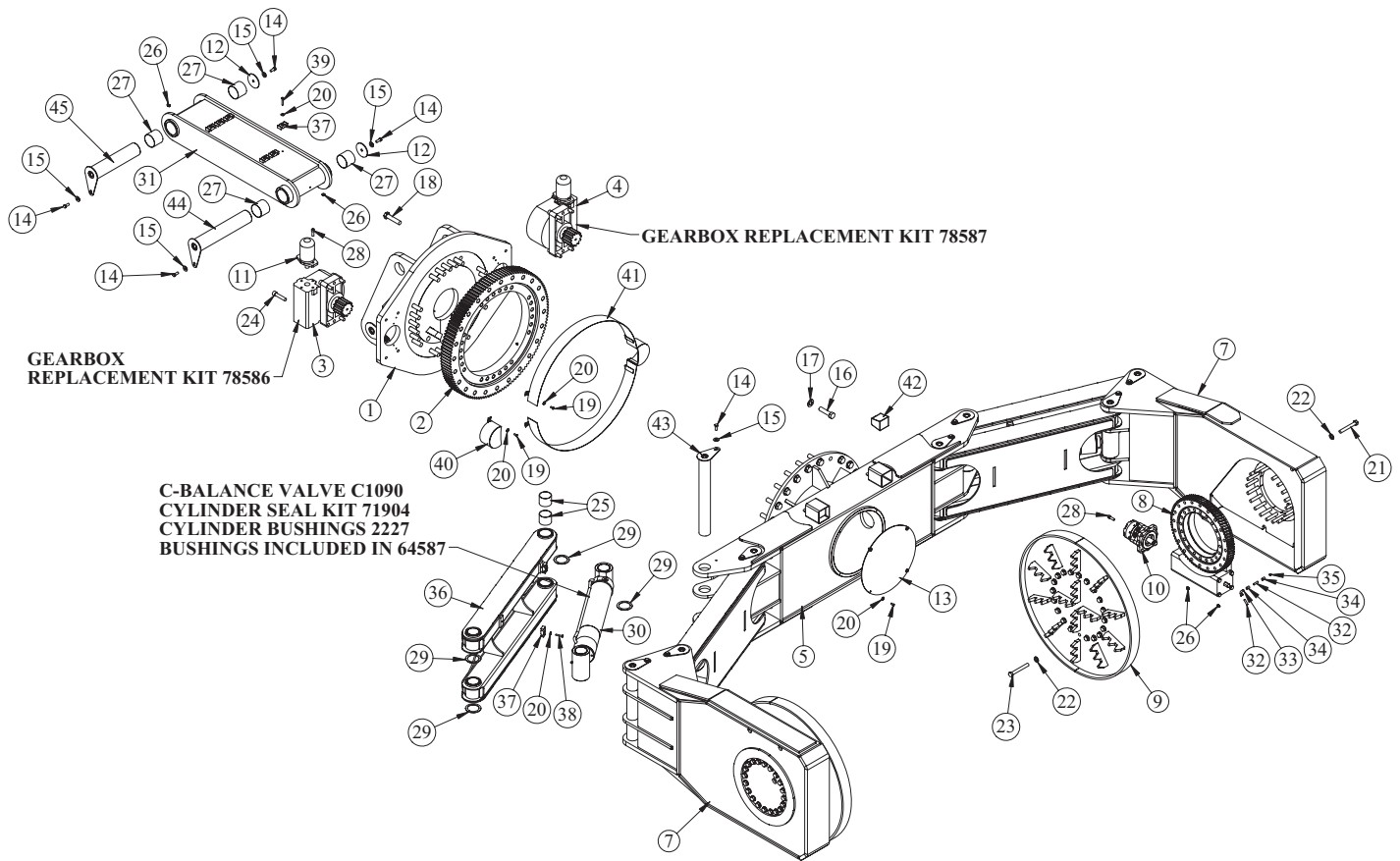

63528

ITEM	PART	DESCRIPTION	QTY.	ITEM	PART	DESCRIPTION	QTY.
1	63519	BASE TM20165	1	16	64851	CAP SCR 1.00-8X4.00 HHGR8	24
2	63518	BEARING TURNABLE TM20165	1	17	6538	WASHER 1.00 SAE FLAT YELLOW GR8	48
3	6537	GEAR BOX 015-00120-1	1	18	18462	CAP SCR 1.00-8X4.50 HHGR8	24
4	64364	GEAR BOX 015-00120-3	1	19	0420	CAP SCR 0.31-18X0.75 HHGR5	12
5	62491	BODY TM20165	1	20	0343	WASHER 0.31 USS FLAT	22
6	63523	LINK TM20165	2	21	64848	CAP SCR 0.75-10X5.50 HHGR8	40
7	63529	ARM TM20165	2	22	C6219	WASHER 0.75 SAE FLAT YELLOW GR8	80
8	63815	BEARING SWING DRIVE 9000 170-00055-5	2	23	C1029	CAP SCR 0.75-10X6.00 HHGR8	40
9	63668	PAD TIRE GRIPPING TM20165 CONT ROT	2	24	11298	CAP SCR 0.75-10X3.50 SH	8
10	64365	MOTOR 9000, WHITE 500260C3120DEAAA	2	25	54374	BUSHING COMPOSITE MRP 3.00X2.50	32
11	5311	MOTOR HYD ROSS MG140611AAAB	2	26	C1597	ZERK 1/8 NPT 90 DEG	6
12	13315	PIN CAP 0.56X4.00X0.19 YZ	11	27	18373	BUSHING BPC56DXR48 3.50X3.00	4
13	64838	COVER TUBE TM20165	1	28	D1295	CAP SCR 0.50-13X1.50 SH	12
14	0498	CAP SCR 0.50-13X1.25 HHGR5	22	29	1589	MACHY WASHER 3.00ID 14GA	20
15	0352	WASHER 0.50 USS FLAT	22	30	64587	CYLINDER 5.00X20.00	2
				31	63680	LINK TM20165	1
				32	C2250	FTG 2-2X1.50 MP-MP NIPPLE STRAIGHT BLK	4
				33	C2239	FTG 2-2 MP-FP STREET ELBOW 90	2
				34	C2256	FTG CPLR PIPE 0.13	4
				35	c1592	ZERK 1/8 NPT STRAIGHT	2
				36	78010	LINK TM20165 OUTSIDE	2
				37	8621	CLAMP HOSE/TUBE AG-3	10
				38	0487	CAP SCR 0.31-18X1.75 HHGR5	4
				39	0488	CAP SCR 0.31-18X2.00 HHGR5	6
				40	22272	GEAR GUARD TM14160B	2
				41	64845	GEAR GUARD TM20165	2
				42	78431	LIGHT FLOOD LED 3.2X2.9 850LM 16W 10-30V	2
				43	64591CR	PIN TEAR DROP 3.00X24.13 CR	8
				44	63943CR	PIN TEAR DROP 3.50X19.13 CR	2
				45	64849CR	PIN TEAR DROP 3.50X16.13 CR	1

NOT SHOWN:
65365 - 1
21409 - 1
D0240 - 1
D1810 - 0.67 FT
D1345 - 1
22161 - 1
56589 - 1
9752 - 2
9756 - 4
8384 - 4

TM20165 Assembly w/Fallback Protection - PN 76685

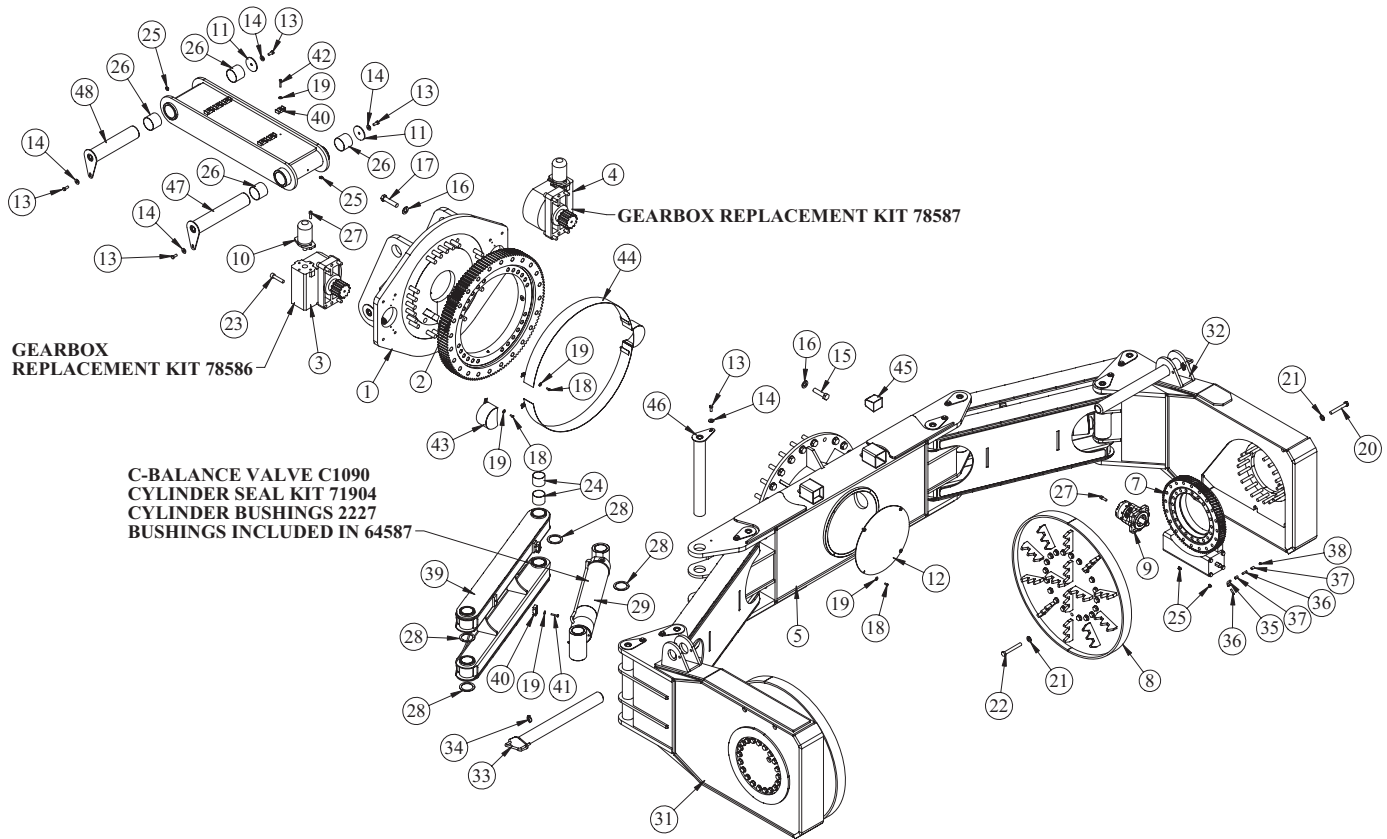

PN 76685

ITEM	PART	DESCRIPTION	QTY.	ITEM	PART	DESCRIPTION	QTY.
1	63519	BASE TM20165	1	22	C1029	CAP SCR 0.75-10X6.00 HHGR8	40
2	63518	BEARING TURNABLE TM20165	1	23	11298	CAP SCR 0.75-10X3.50 SH	8
3	6537	GEAR BOX 015-00120-1	1	24	54374	BUSHING COMPOSITE MRP 3.00X2.50	32
4	64364	GEAR BOX 015-00120-3	1	25	C1597	ZERK 1/8 NPT 90 DEG	6
5	62491	BODY TM20165	1	26	18373	BUSHING BPC56DXR48 3.50X3.00	4
6	63523	LINK TM20165	2	27	D1295	CAP SCR 0.50-13X1.50 SH	12
7	63815	BEARING SWING DRIVE 9000 170-00055-5	2	28	1589	MACHY WASHER 3.00ID 14GA	20
8	63668	PAD TIRE GRIPPING TM20165 CONT ROT	2	29	64587	CYLINDER 5.00X20.00	2
9	64365	MOTOR 9000, WHITE 500260C3120DEAAA	2	30	63680	LINK TM20165	1
10	5311	MOTOR HYD ROSS MG140611AAAB	2	31	76686	ARM TM20165 W/FALLBACK RH	1
11	13315	PIN CAP 0.56X4.00X0.19 YZ	11	32	76687	ARM TM20165 W/FALLBACK LH	1
12	64838	COVER TUBE TM20165	1	33	53056	WELDMENT PIN FALLBACK TM16160	2
13	0498	CAP SCR 0.50-13X1.25 HHGR5	22	34	5753	PIN 0.19X1.56 LYNCH	2
14	0352	WASHER 0.50 USS FLAT	22	35	C2239	FTG 2-2 MP-FP STREET ELBOW 90	2
15	64851	CAP SCR 1.00-8X4.00 HHGR8	24	36	C2250	FTG 2-2X1.50 MP-MP NIPPLE STRAIGHT BLK	4
16	6538	WASHER 1.00 SAE FLAT YELLOW GR8	48	37	C2256	FTG CPLR PIPE 0.13	4
17	18462	CAP SCR 1.00-8X4.50 HHGR8	24	38	c1592	ZERK 1/8 NPT STRAIGHT	2
18	0420	CAP SCR 0.31-18X0.75 HHGR5	12	39	78010	LINK TM20165 OUTSIDE	2
19	0343	WASHER 0.31 USS FLAT	22	40	8621	CLAMP HOSE/TUBE AG-3	10
20	64848	CAP SCR 0.75-10X5.50 HHGR8	40	41	0487	CAP SCR 0.31-18X1.75 HHGR5	4
21	C6219	WASHER 0.75 SAE FLAT YELLOW GR8	80	42	0488	CAP SCR 0.31-18X2.00 HHGR5	6
				43	22272	GEAR GUARD TM14160B	2
				44	64845	GEAR GUARD TM20165	2
				45	78431	LIGHT FLOOD LED 3.2X2.9 850LM 16W 10-30V	2
				46	64591CR	PIN TEAR DROP 3.00X24.13 CR	8
				47	63943CR	PIN TEAR DROP 3.50X19.13 CR	2
				48	64849CR	PIN TEAR DROP 3.50X16.13 CR	1

NOT SHOWN:

- 65365 - 1
- 21409 - 1
- D0240 - 1
- D1810 - 0.67 FT
- D1345 - 1
- 22161 - 1
- 56589 - 1
- 9752 - 2
- 9756 - 4
- 8384 - 4

Crane Assembly - PN 81760 Part 1

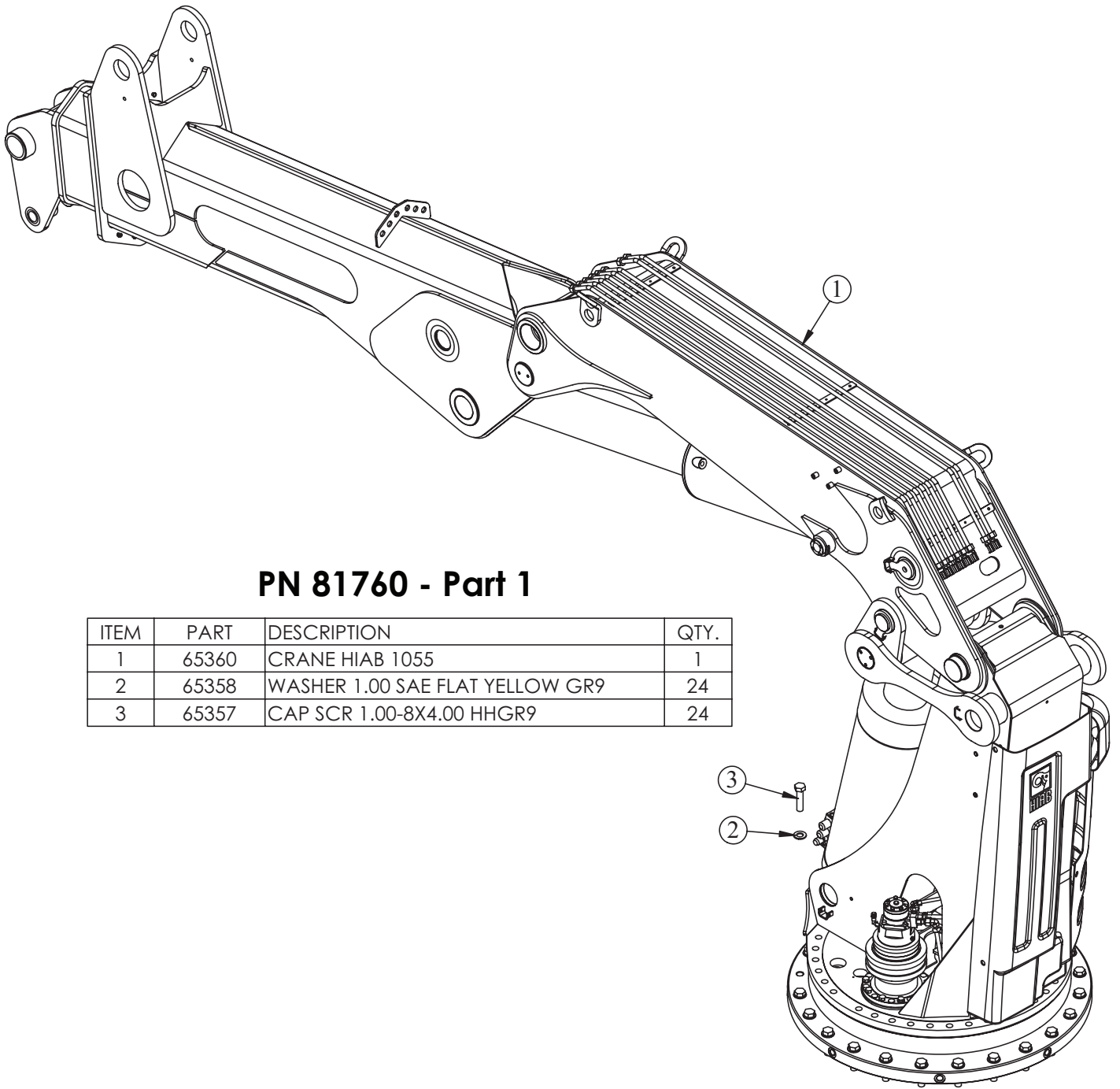

PN 81760 - Part 1

ITEM	PART	DESCRIPTION	QTY.
1	65360	CRANE HIAB 1055	1
2	65358	WASHER 1.00 SAE FLAT YELLOW GR9	24
3	65357	CAP SCR 1.00-8X4.00 HHGR9	24

Crane Assembly - PN 81760 Part 2

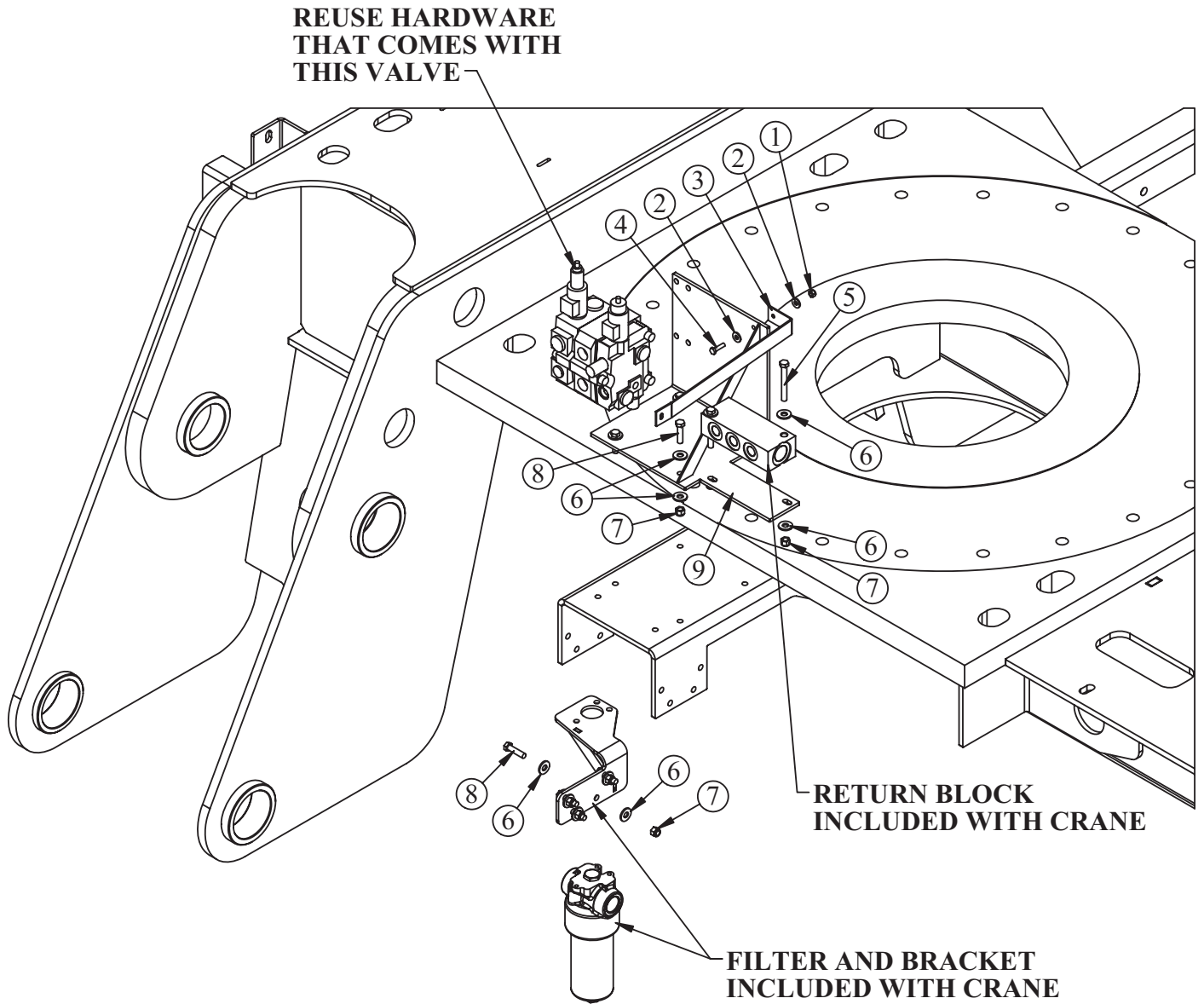

PN 81760 - Part 2

ITEM	PART	DESCRIPTION	QTY.
1	0333	NUT 0.25-20 HHGR5 NYLOC	1
2	0340	WASHER 0.25 USS FLAT	2
3	65966	BRKT REINFORCEMENT LOAD SENSE	1
4	0480	CAP SCR 0.25-20X1.00 HHGR5	1
5	C0949	CAP SCR 0.38-16X3.00 HHGR5	2
6	0346	WASHER 0.38 USS FLAT	44
7	0347	NUT 0.38-16 HHGR5 NYLOC	25
8	0345	CAP SCR 0.38-16X1.50 HHGR5	8
9	65871	BRKT WLDMT LOAD SENSE VALVE 65000	1

Crane Assembly - PN 81760 Part 3

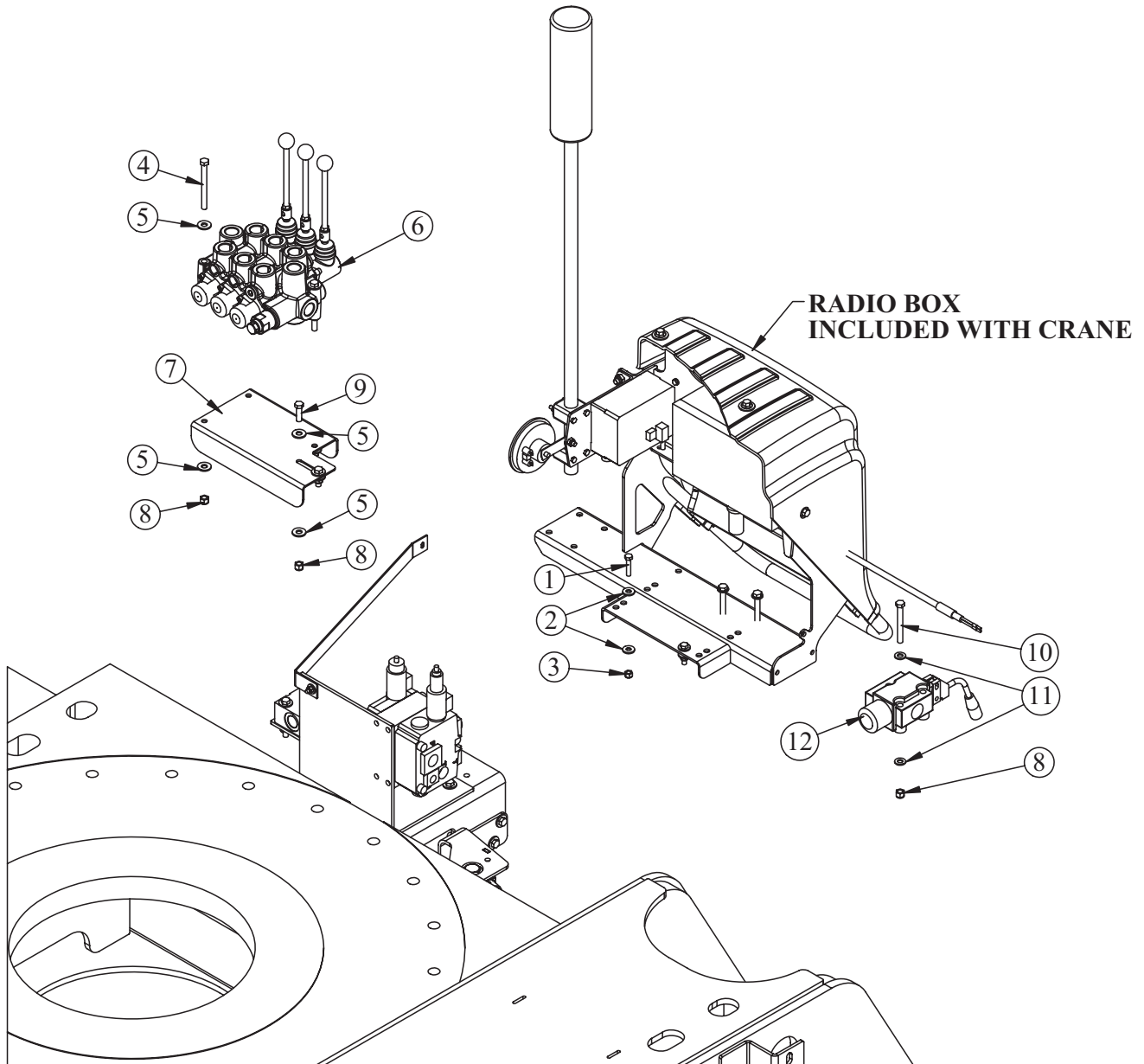

PN 81760 - Part 3

ITEM	PART	DESCRIPTION	QTY.
1	0486	CAP SCR 0.31-18X1.50 HHGR5	2
2	0343	WASHER 0.31 USS FLAT	4
3	0342	NUT 0.31-18 HHGR5 NYLOC	2
4	C0953	CAP SCR 0.38-16X4.00 HHGR5	6
5	0346	WASHER 0.38 USS FLAT	44
6	81026	VB STABILIZERS TM20165	1
7	80993	BRACKET VB MNT 65000 OUTRIGGER SS	1
8	0347	NUT 0.38-16 HHGR5 NYLOC	25
9	0335	CAP SCR 0.38-16X1.25 HHGR5	6
10	C0950	CAP SCR 0.38-16X3.25 HHGR5	3
11	C6353	WASHER 0.38 SAE FLAT YELLOW GR8	6
12	81025	VALVE DIVERTER HIAB TM20165	1

Crane Assembly - PN 81760 Part 4

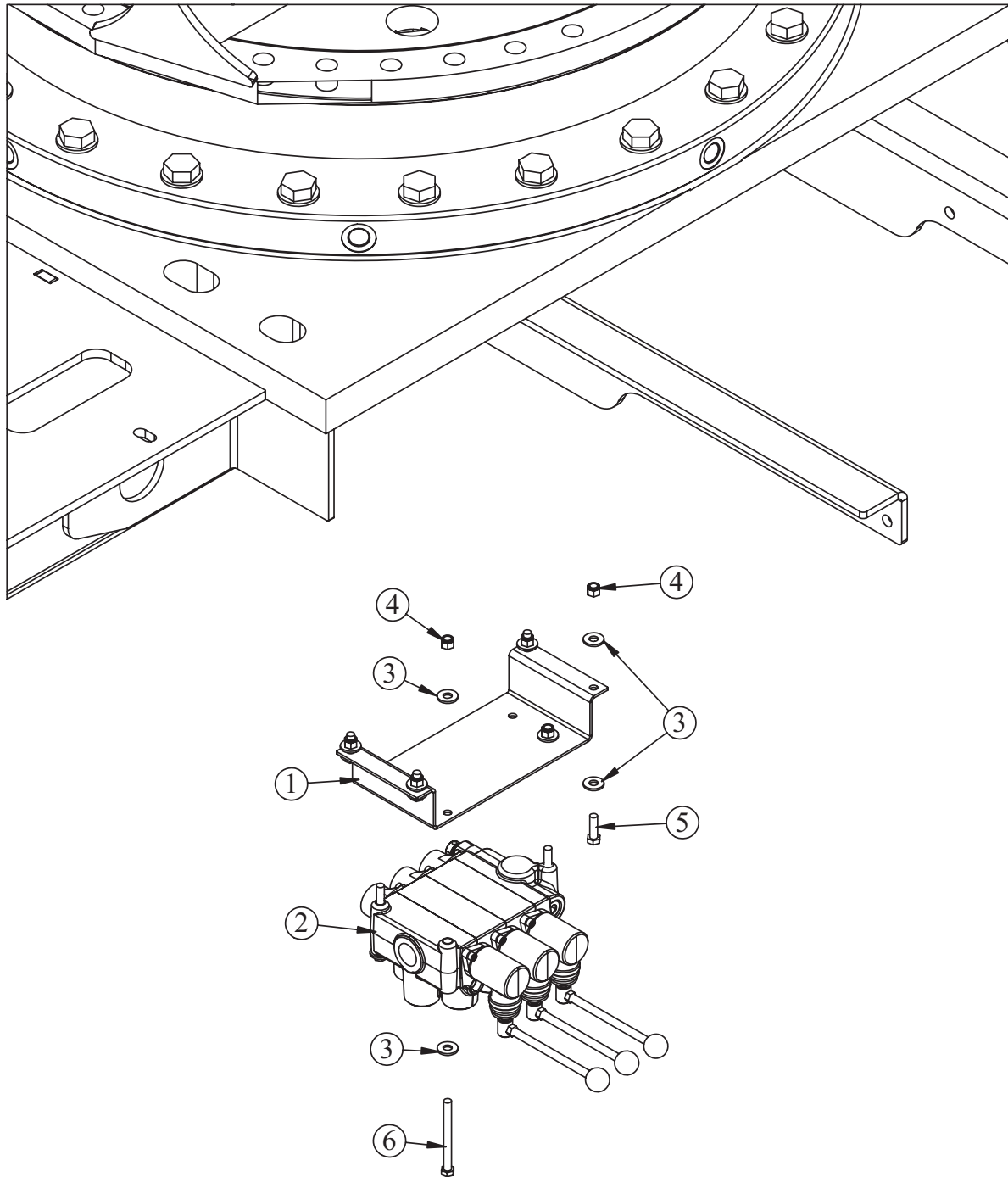

PN 81760 - Part 4

ITEM	PART	DESCRIPTION	QTY.
1	80992	BRACKET VB MNT 65000 OUTRIGGER CS	1
2	81026	VB STABILIZERS TM20165	1
3	0346	WASHER 0.38 USS FLAT	44
4	0347	NUT 0.38-16 HHGR5 NYLOC	25
5	0335	CAP SCR 0.38-16X1.25 HHGR5	6
6	C0953	CAP SCR 0.38-16X4.00 HHGR5	6

Mounting Kit Subframe Assembly - Part 1

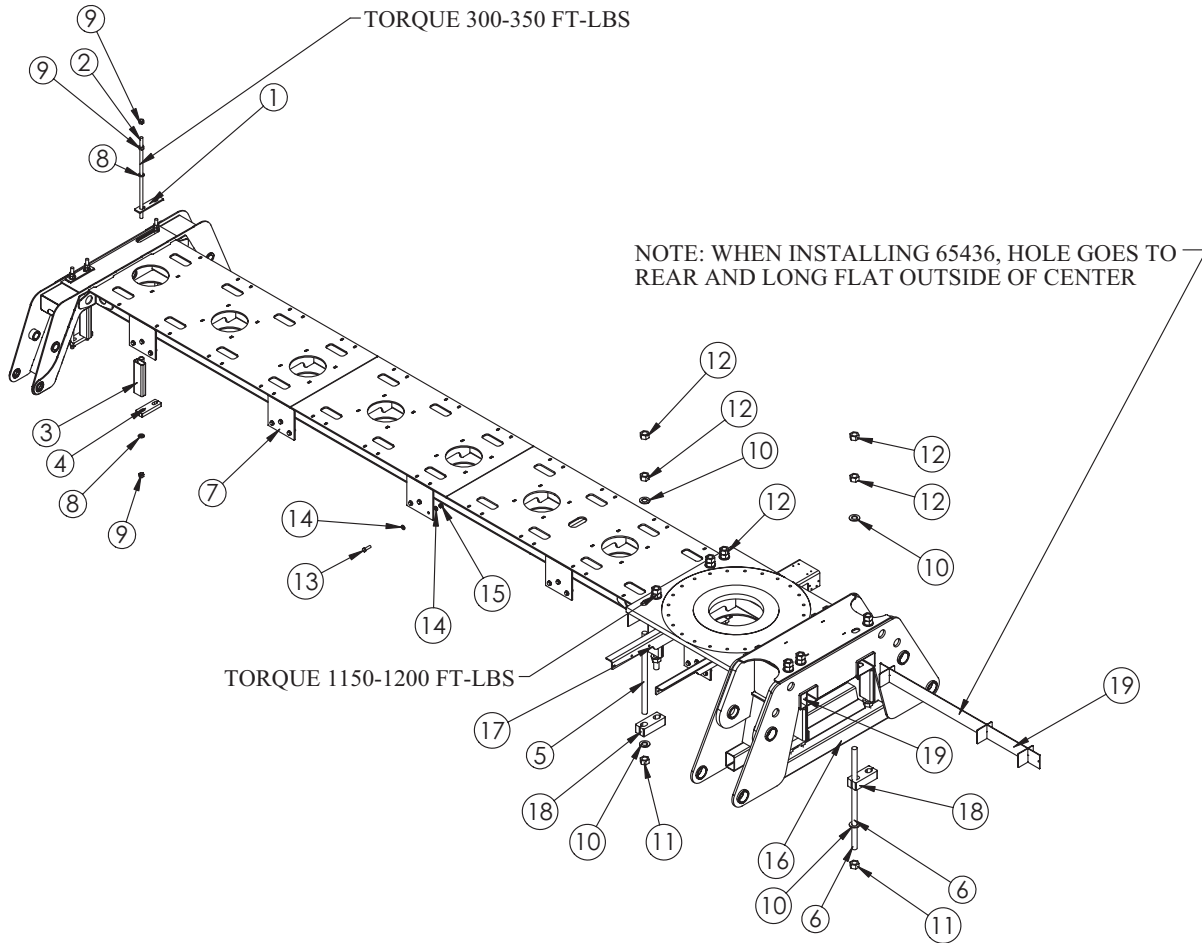

PN 65349

ITEM	PART	DESCRIPTION	QTY.
1	58660	PLATE MOUNTING HIAB 122	2
2	58516	TIE DOWN ROD HIAB 122	4
3	8202PC	FRAME SUPPORT 15000 CRANE	2
4	58658	MTG BLOCK HIAB 122	2
5	65350	TIE DOWN ROD 1.75-5X32.00	8
6	65354	TIE DOWN ROD 1.75-5X40.00	4
7	65433	SHEAR PLATE 0.50X12.00X12.00	10
8	6538	WASHER 1.00 SAE FLAT YELLOW GR8	8
9	61558	NUT 1.00-8 HHGR8	12
10	65098	WASHER 1.75 USS FLAT ZINC	24
11	65100	NUT 0.50-13 HHGR5 NYLOC	12
12	65099	NUT 0.50-13 HHGR5 NYLOC	24
13	58681	CAP SCR 0.75-10X2.50 HHGR8	30
14	C6219	WASHER 0.75 SAE FLAT YELLOW GR8	60
15	C0538	NUT 0.75-10 HHGR8 NYLOC	30
16	64982	TUBE 6.00X4.00X0.25WX64.00 100,000 PSI	2
17	65356PC	FRAME SUPPORT 65000	6
18	65352PC	MTG BLOCK 65000	6
19	65436	BRKT TUBE REINF WLDMT 65000	2

Mounting Kit Subframe Assembly - Part 2

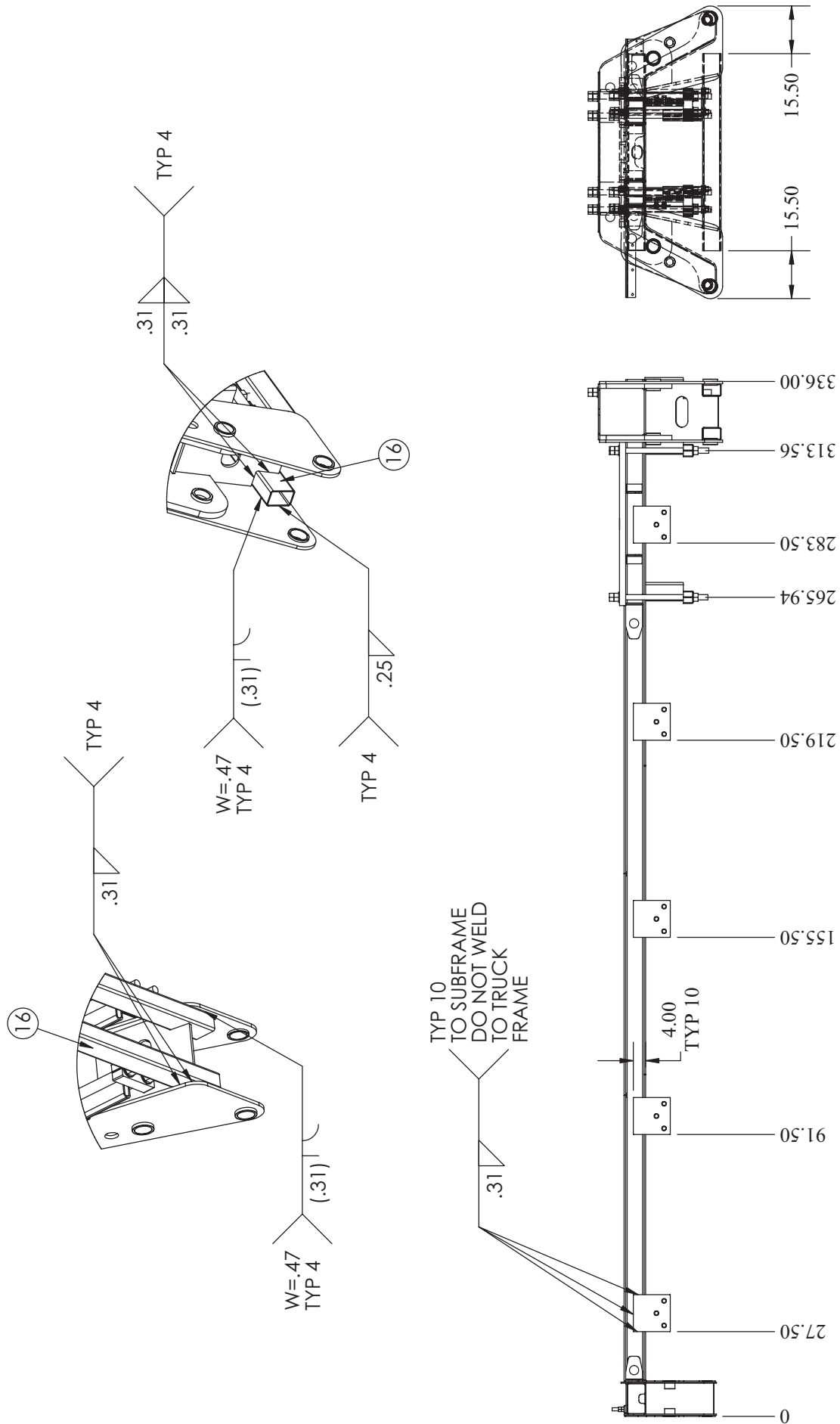

Crane Base Stabilizer Assembly - PN 65107

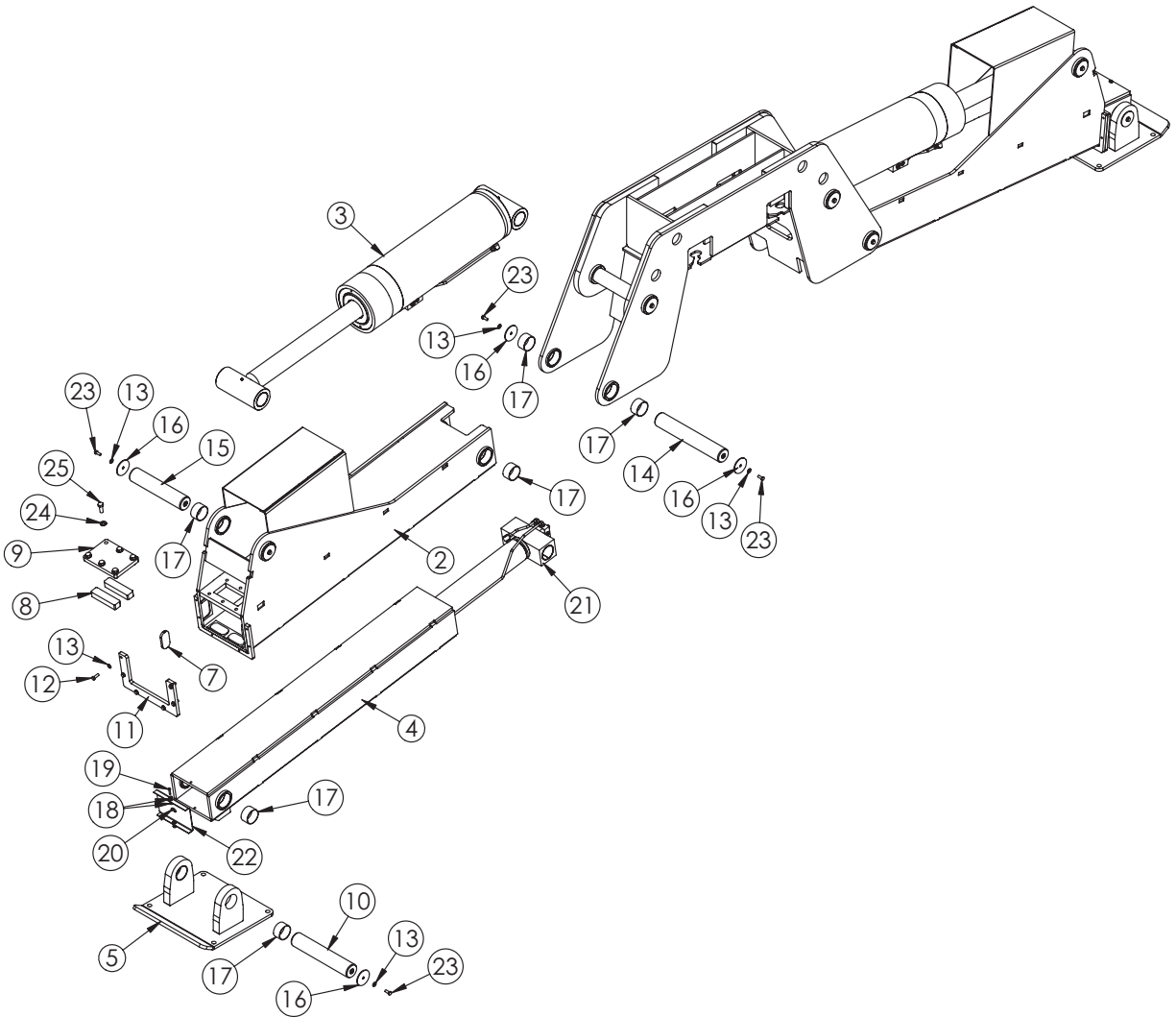

PN 65107

ITEM	PART	DESCRIPTION	QTY.
1	66856	SUBFRAME WLDMT BOLT ON 190-220 OTR REAR	1
2	64369	HOUSING STABILIZER LEG 65000	2
3	64367	CYLINDER ASM STABILIZER 65000	1
4	64372	LEG STABILIZER EXT 65000	2
5	64964	PAD STABILIZER 65000	2
6	64367	CYLINDER ASM STABILIZER 65000	1
7	38739	WEAR PAD SLIDER65	8
8	40455	WEAR PAD 2.00X8.00X1.50	4
9	64971	PLATE WEAR PAD COVER 65000	2
10	65103CR	PIN 3.50X18.69 D&T	2
11	64974	PLATE WEAR PAD COVER STABILIZER 65000	2
12	10548	CAP SCR 0.50-13X1.50 HHGR8	12
13	D0790	WASHER 0.50 SAE FLAT YELLOW GR8	28
14	65101CR	PIN 3.50X21.38 D&T	4
15	65102CR	PIN 3.50X17.13 D&T	2
16	13315	PIN CAP 0.56X4.00X0.19 YZ	16
17	64980	BUSHING COMPOSITE MRP 3.50X2.00	24
18	0343	WASHER 0.31 USS FLAT	8
19	0486	CAP SCR 0.31-18X1.50 HHGR5	4
20	0342	NUT 0.31-18 HHGR5 NYLOC	4
21	64970	CYLINDER ASM EXT 65000	2
22	65934	COVER STABILIZER LEG TM20165	2
23	10666	CAP SCR 0.50-13X1.25 HHGR8	16
24	C6219	WASHER 0.75 SAE FLAT YELLOW GR8	12
25	4543	CAP SCR 0.75-10X2.00 HHGR8	12

Crane Base Stabilizer Cylinder Assembly - PN 64367

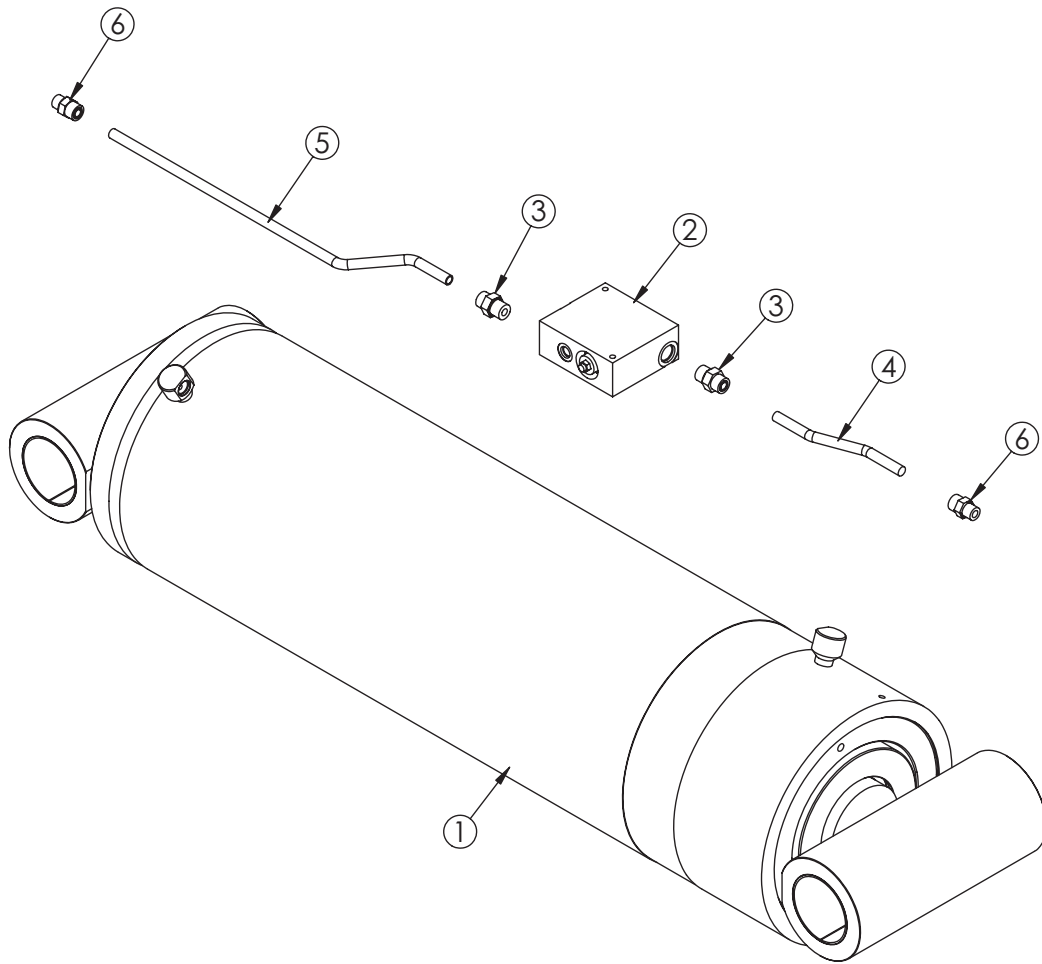

PN 64367

ITEM	PART	DESCRIPTION	QTY.
1	64368	CYLIDNER 11.00X34.00	1
2	15995	MANIFOLD ASM DUAL T2A 5000PSI	1
3	C2252	FTG 8-10 MFS-MORB STRAIGHT	2
4	54416	TUBE ASM 0.50X7.56 17000 YZ	1
5	64972	TUBE ASM 0.50X20.80 YZ	1
6	1554	FTG 8-8 MFS-MORB STRAIGHT	2

Non-Crane Base Stabilizer Assembly - PN 64262

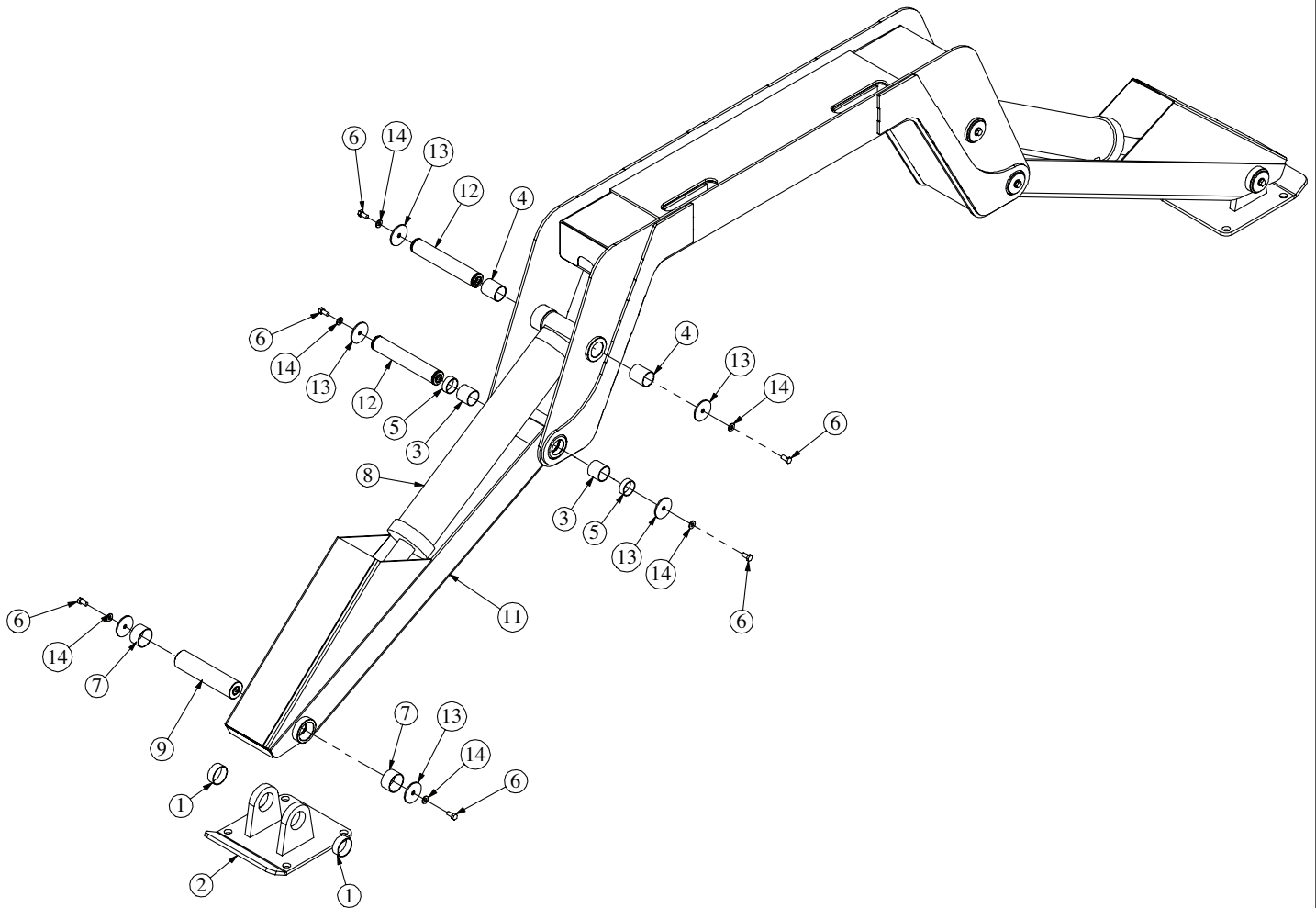

PN 64262

ITEM	PART	DESCRIPTION	QTY.
1	13343	BUSHING BPC40DXR16 2.50X1.00	4
2	66282	OUTRIGGER PAD 9000/TM20165	2
3	4381	BUSHING BPC32DXR32 2.00X2.00	4
4	4379	BUSHING BPC32DXR40 2.00X2.50	4
5	94747	BUSHING BPC32DXR12 2.00X0.75	4
6	10172	CAP SCR 0.50-13X1.00 HHGR8	12
7	13817	BUSHING BPC40DXR24 2.50X1.50	4
8	66283	CYLINDER 5.00X24.50 WHITE	2
9	54322ZP	PIN 2.50X10.38 D&T	2
11	66281	OUTRIGGER LEG WLDMT 9000/TM20165	2
12	9710ZP	PIN 2.00X11.69 SR/D&T	4
13	5145	PIN CAP 0.56X3.00X0.19	12
14	D0790	WASHER 0.50 SAE FLAT YELLOW GR8	12

Non-Crane Base Stabilizer Extension Cylinder Assembly - PN 64367

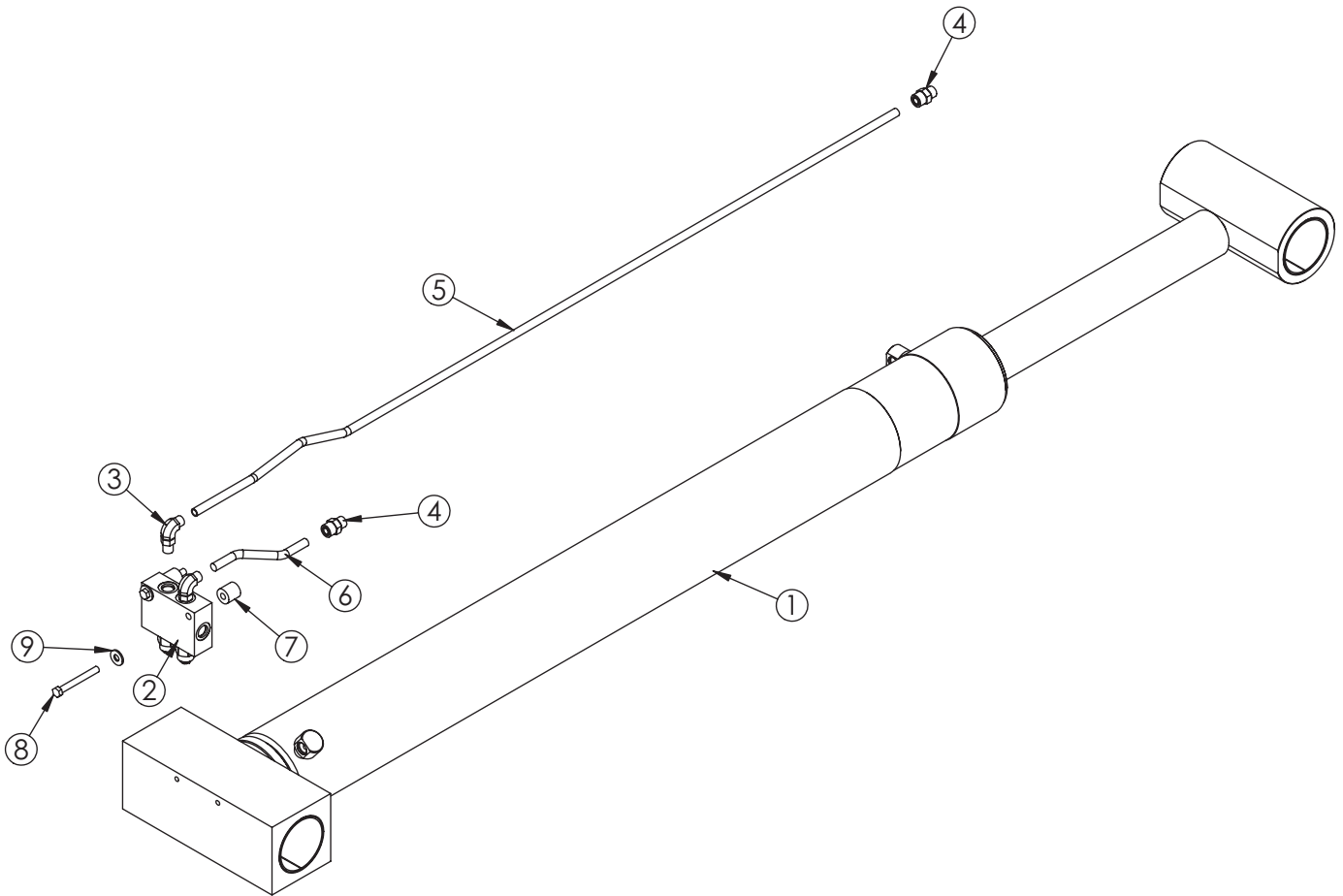

PN 64970

ITEM	PART	DESCRIPTION	QTY.
1	64599	CYLINDER 5.00X43.00	1
2	64978	MANIFOLD ASM DUAL T2A 5000PSI YAJ BLOCK	1
3	1556	FTG 8-8 MFS-MAORB 90	2
4	1554	FTG 8-8 MFS-MORB STRAIGHT	2
5	64973	TUBE ASM 0.50X63.06 YZ	1
6	16256	TUBE ASM 0.50X6.25 YZ	1
7	12936	SPACER 1.00 X 1.00OD X .406ID	2
8	C0950	CAP SCR 0.38-16X3.25 HHGR5	2
9	0346	WASHER 0.38 USS FLAT ZINC	2

Reservoir Assembly - PN 86517

PN 86517

ITEM	PART	DESCRIPTION	QTY.
1	60782	BUSHING 2.00X1.50 BLK	2
2	0478	CAP SCR 0.25-20X0.50 HHGR5	12
3	C0922	CAP SCR 0.31-18X1.00 HHGR5	8
4	0492	CAP SCR 0.38-16X0.75 HHGR5	8
5	0501	CAP SCR 0.50-13X2.00 HHGR5	6
6	37541	FTG 24-24 MP-HB STRAIGHT	2
7	19242	FTG 20-20 MFS-MORB STRAIGHT	2
8	0554	FTG 6-6 MFS-MP STRAIGHT	2
9	11149	GASKET ARCTIC FOX HEATER #A-611	1
10	C2126	MAGNETIC PLUG DRAIN 3/4"	1
11	C1060	FTG 24-24XCLOSE MP-MP NIPPLE STRAIGHT BLK	2
12	0342	NUT 0.31-18 HHGR5 NYLOC	8
13	C6106	NUT 0.50-13 HHGR5 NYLOC	6
14	11442	PLATE COVER TANK HEATER FLANGE PC WHITE	1
15	C4841	PLUG 0.38 NPT SQ HD BLK	1
16	4195	FTG 24-24 MP-FP STREET ELBOW 90 BLK	2
17	54393	SWITCH TEMP NC TT-F5B-100R-MP	2
18	15463	THERMO SIGHT GAUGE ZINGA SG-O5-A-T-N	1
19	37539	VALVE BALL 1.50	2
20	0340	WASHER 0.25 USS FLAT	12
21	0343	WASHER 0.31 USS FLAT	16
22	0352	WASHER 0.50 USS FLAT	12
23	65672	FTG 16-16 MFS-FFSS 45	1
24	86518	RSRVR 80GAL V2 65000	1
25	85928	FILTER TANK TOP 20 FORB	2
26	58396	GASKET RG-11 TANK TOP FILTER	2
27	85790	COOLER OIL MAR-32	2
28	51294	HOSE 1.25(200PSI)-20FFSS SHORT-20FFSS SHORT-20CL	2
29	81018	CAP FILL NO RELIEF ZINGA THREADED	1
30	51275	FTG 20-16 MFS-MAORB 90	3
31	59959	FTG 16-16 MFS-MAORB 90	1
32	60394	FTG 16-16 MFS-FFSS-MFS RUN TEE	1

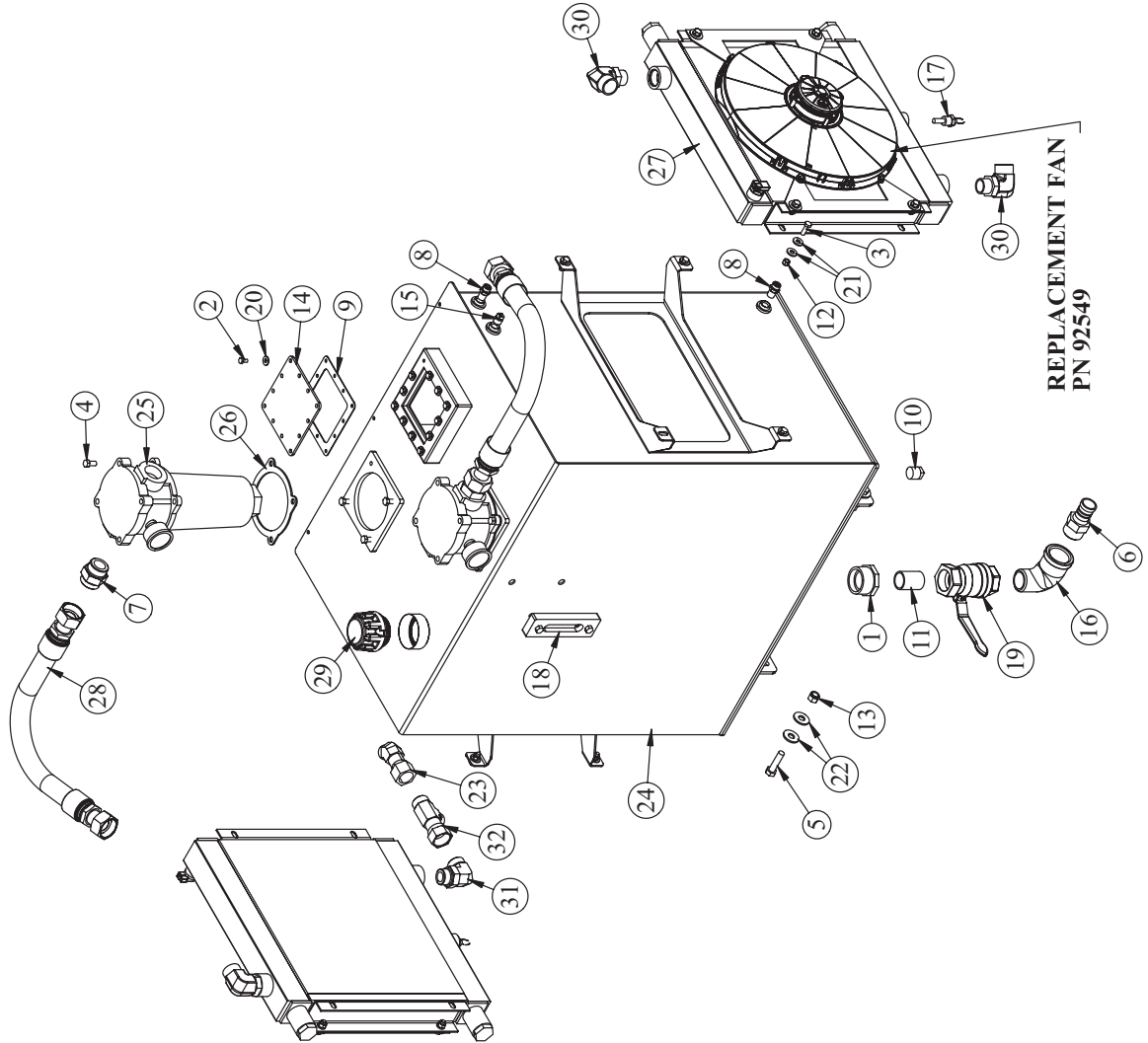



Subject to Change without Notification.
© 2022 Stellar Industries, Inc.