



MODEL EC4000

TELESCOPIC CRANE

OWNERS' MANUAL

Installation • Assembly Drawings • Parts

20 Ft Version

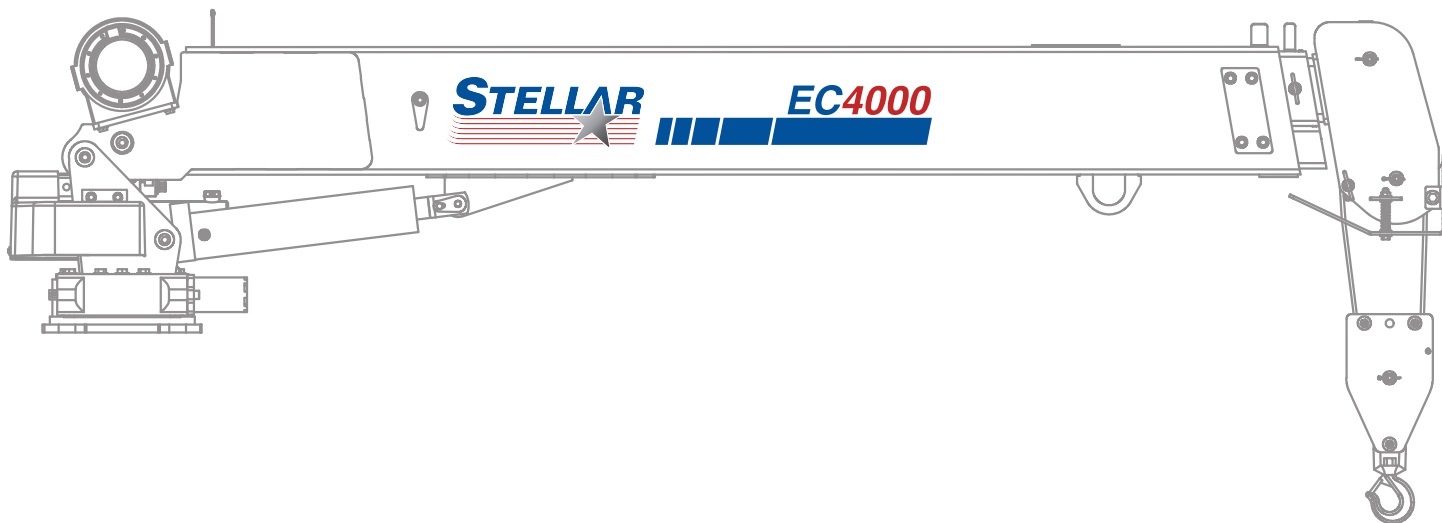

Notice: A copy of this manual must remain with the equipment at all times.
For a printable download copy, please visit: www.stellarindustries.com

Stellar Industries, Inc.

190 State Street

PO Box 169

Garner, IA 50438

800-321-3741

Fax: 641-923-2811

www.stellarindustries.com

Subject to Change without Notification.
© 2023 Stellar Industries, Inc.

Rev 1
PN 65777

Warnings/Notice/Serial Tag

⚠ WARNING

Operating, maintaining, and servicing a Stellar product may expose you to chemicals including, but not limited to, engine exhaust, carbon monoxide, phthalates, and lead. These chemicals are known to the State of California to cause cancer and birth defects (or other reproductive harm). To keep your exposure to a minimum, be sure to avoid breathing exhaust and service your Stellar product in a well-ventilated area while wearing gloves or washing your hands frequently. For more information, go to www.P65Warnings.ca.gov/passenger-vehicle.



www.p65warnings.ca.gov

NOTICE

Cold Weather Performance

Although clear data on cold weather performance from every steel manufacturer is not available for all types and thicknesses of steel, Stellar Industries is confident that the weldments on our products will operate to 100% of their intended purpose to temperatures down to -40° F / C.

It is recommended if Stellar manufactured equipment needs to be used in temperatures below -40° F / C, the operator should pull the unit into a climate-controlled area and allow the weldments to warm up to and then maintain a temperature above this level.

Serial Tag Location

STELLAR [®]		DATE
PATENT INFORMATION http://www.stellarindustries.com/ip		
MODEL NO.	SERIAL NO.	
MADE IN THE U.S.A. BY STELLAR INDUSTRIES, INC. PN C5942		

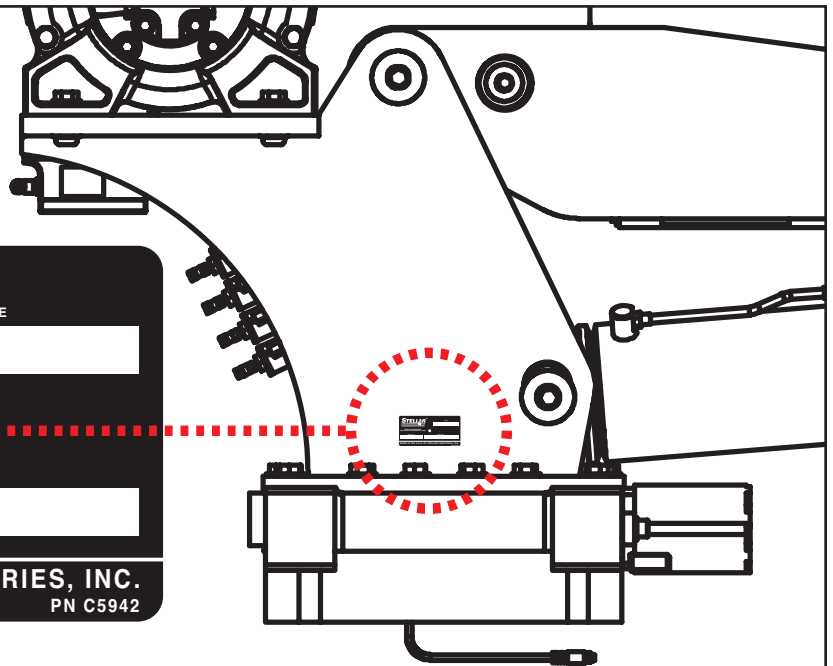

Table of Contents

Introduction	ii
Chapter 1 - Specifications	1
EC4000-20 Dimensions	2
Capacity Chart - Decal PN 51283	3
Chapter 2 - Installation	4
General Installation	4
Installer Notice	4
Torque Data Chart	5
Installation Overview	6
EC4000 Mounting Detail	7
Flatbed Body Reinforcement	7
EC4000 Installation Drawing	8
Hydraulic Kit - PN 51282	9
Valve Bank Drawing	10
Control Kit - PN 42804	12
Control Kit - PN 42804 Parts List	13
Control Kit (24V Option) - PN 67932	14
EC4000 Wiring Diagram	15
Electrical Circuit Grounding	16
Stability Procedure	17
Decal Kit Placement - PN 51286	18
Chapter 3 - Assembly Drawings	19
Base Assembly - PN 71896	19
Mast Assembly - PN 50368	20
Power Unit Assembly - PN 42513	21
Mast Assembly (24V Option) - PN 67930	22
Main Boom Assembly - PN 50509	23
Main Boom Assembly (24V Option) - PN 67868	24
Extension Boom Assembly - PN 50611	25
Gear Bearing Assembly - PN 69735	26
Cable & Hook Assembly - PN 50492	27
Radio Transmitter Assembly - PN 67894	28

Introduction

A copy of this manual is provided with every crane and can be found in the hard plastic manual case that is installed on the chassis. A copy of this manual shall remain with the crane at all times.

Throughout the manual, three signal words will be used to bring attention to important items:

A NOTICE signal word indicates a practice not related to physical injury.

NOTICE

A WARNING signal word indicates a hazardous situation which, if not avoided, could result in death or serious injury.

⚠ WARNING

A DANGER signal word indicates a hazardous situation which, if not avoided, will result in death or serious injury.

⚠ DANGER

Information contained within this manual does not cover operation, maintenance, or troubleshooting. Please refer to the General EC Crane Manual for details on these items.

This manual is not binding. Stellar Industries, Inc. reserves the right to change, at any time, any or all of the items, components, and parts deemed necessary for product improvement or commercial/production purposes. This right is kept with no requirement or obligation for immediate mandatory updating of this manual.

In closing:

If more information is required or technical assistance is needed, or if you feel that any part of this manual is unclear or incorrect, please contact the Stellar Customer Service Department by phone at 800-321-3741 or email at service@stellarindustries.com.

**For Technical Questions, Information, Parts, or Warranty, Call Toll-Free at
800-321-3741**

Hours: Monday - Friday, 8:00 a.m. - 5:00 p.m. CST

Or email at the following addresses:

Technical Questions, and Information

service@stellarindustries.com

Order Parts

parts@stellarindustries.com

Warranty Information

warranty@stellarindustries.com

Chapter 1 - Specifications

Model EC4000-20ft Version Crane SPECIFICATION SHEET

Crane Rating:	16,000 ft-lb (2.21 TM)
Standard Boom Length:	10' (3.05 m) from CL of Crane
Boom Extension:	1st stage: Hydraulic 60" (152.4 cm) 2nd stage: Manual 60" (152.4 cm)
Maximum Horizontal Reach:	20' (6.10 m) from CL of Crane
Maximum Vertical Lift: (from crane base)	21' 3" (6.48 m)
Boom Elevation:	-5 to +80 degrees
Stowed Height: (crane only)	29.53" (75 cm)
Mounting Space Required:	19" x 19" (48.3 x 48.3 cm)
Approximate Crane Weight:	1180 lbs (535 kg)
Controls:	Radio control standard for all functions.
Winch Specifications	
Rope Length:	90 ft (27.4 m)
Rope Diameter:	5/16" (.79 cm)
Line pull speed:	15 ft/min (4.6 m/min)
Max. single part line:	2000 lbs (905 kg)
Max. double part line:	4000 lbs (1815 kg)
Rotation: (worm gear)	410 degree power
Lifting Capacities:	4000 lbs @ 4' (1814 kg @ 1.22 m) 1065 lbs @ 15' (480 kg @ 4.57 m) 800 lbs @ 20' (360 kg @ 6.1 m)
Power Supply Required:	12 volt power unit (2.0 gpm @ 2300 psi) (7.57 lpm @ 159 bars)

*Subject to change without notification

EC4000-20 Dimensions

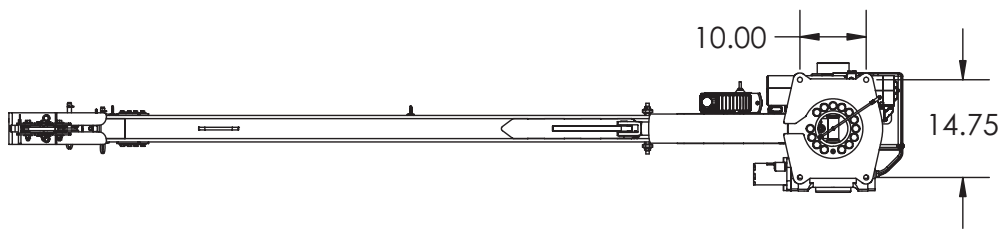
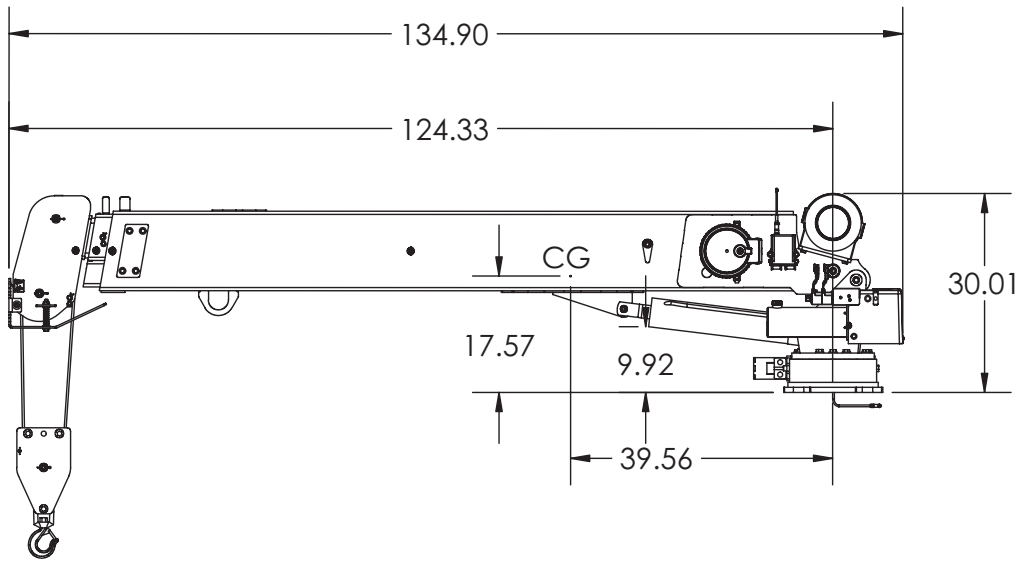
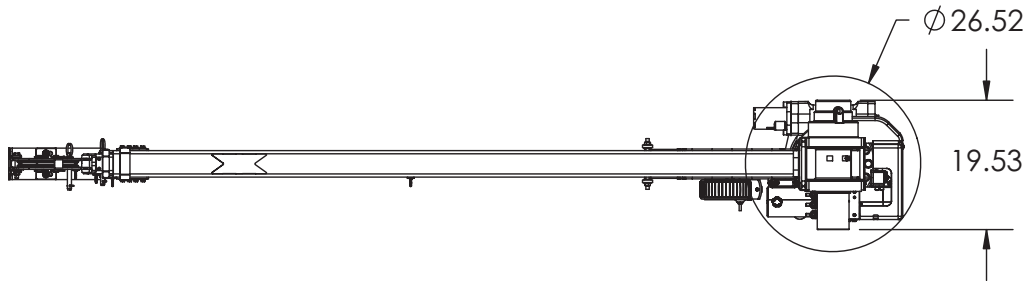

Capacity Chart - Decal PN 51283

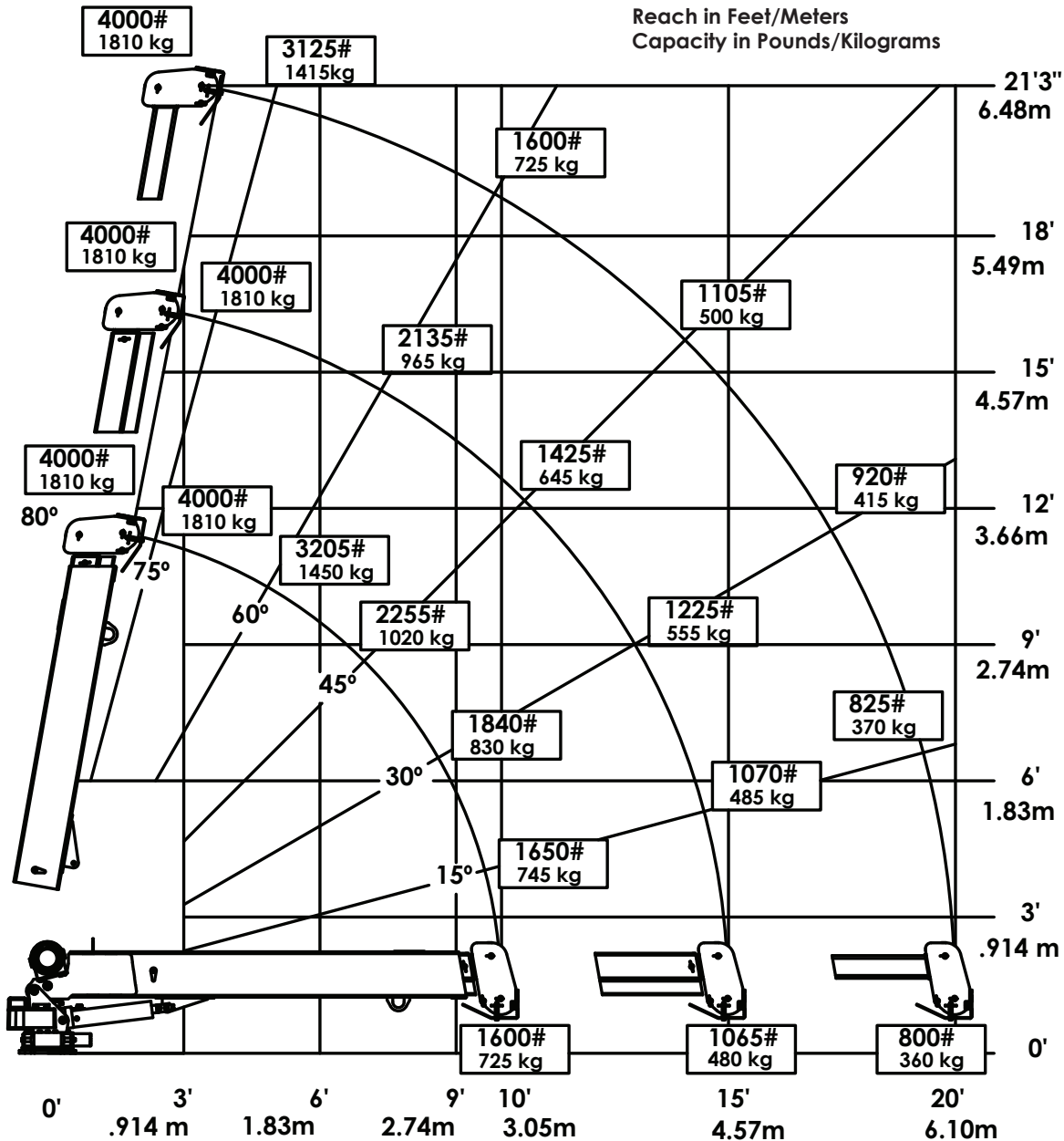

Weight of load handling devices are part of the load lifted and must be deducted from the capacity.

Maximum 1 - part line capacity is 2000lbs (905kg). For greater loads, use 2 - part line.



PN 51283

Chapter 2 - Installation

General Installation

This chapter is designed to serve as a general guide for the installation of a EC4000 Crane. Each installation is considered unique so certain portions of this chapter may or may not apply to your direct application. If a question should arise during the installation process, please contact Stellar Customer Service at (800) 321 3741.

It is the installer's responsibility to assure that the crane is mounted on a platform that will support the maximum crane rating of this crane.

⚠ WARNING Do not install this crane on a body not capable of handling the loads imposed on it. Failure to do so may result in serious injury or death.

NOTICE When installing welder units to the service bodies, it is highly recommended that a surge protector is installed on the chassis batteries to protect the crane radio receiver, wiring and other electronic devices from an unexpected electrical spike or surge. Failure to do so could result in extensive damage to the service body and crane electrical circuit.

Installer Notice

According to Federal Law (49 cfr part 571), each final-stage manufacturer shall complete the vehicle in such a manner that it conforms to the standards in effect on the date of manufacture of the incomplete vehicle, the date of final completion, or a date between those two dates. This requirement shall, however, be superseded by any conflicting provisions of a standard that applies by its terms to vehicles manufactured in two or more stages.

Therefore, the installer of Stellar® Cranes and Bodies is considered one of the manufacturers of the vehicle. As such a manufacturer, the installer is responsible for compliance with all applicable federal and state regulations. They are required to certify that the vehicle is in compliance with the Federal Motor Vehicle Safety Standards and other regulations issued under the National Traffic and Motor Vehicle Safety Act.

Please reference the Code of Federal Regulations, title 49 - Transportation, Volume 5 (400-999), for further information, or visit <http://www.gpoaccess.gov/nara/index.html> for the full text of Code of Federal Regulations.

Torque Data Chart

When using the torque data in the chart, the following rules should be observed:

- Bolt manufacturer's particular specifications should be consulted when provided.
- Flat washers of equal strength must be used.
- All torque measurements are given in foot-pounds. To convert to inch-pounds, multiply by 12.
- Torque values specified are for bolts with residual oils or no special lubricants applied. If special lubricants of high stress ability, such as Never-Seez compound graphite and oil, molybdenum disulphite, colloidal copper or white lead are applied, multiply the torque values in the charts by the factor .90. The use of Loctite does not affect the torque values listed above.
- Torque values for socket-head capscrews are the same as for Grade 8 capscrews.
- Do not use these values if a different torque value or tightening procedure is given for a specific application. Torque values listed are for general use only. Check tightness of fasteners periodically.
- Shear bolts are designed to fail under predetermined loads. Always replace shear bolts with identical grade.
- Fasteners should be replaced with the same or higher grade. If higher grade fasteners are used, these should only be tightened to the strength of the original.
- Tighten plastic insert or crimped steel-type lock nuts to approximately 110 percent of the dry torque values shown in the chart below, applied to the nut, not to the bolt head. Tighten toothed or serrated-type lock nuts to the full torque value. *Note: "Lubricated" means coated with a lubricant such as engine oil, or fasteners with phosphate and oil coatings. "Dry" means plain or zinc plated without lubrication. Tighten lubricated bolts to approximately 80% of dry bolts.*

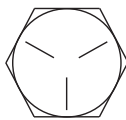
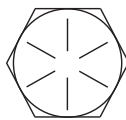
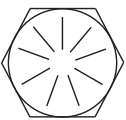
		GRADE 5		GRADE 8		GRADE 9
						
Size (DIA-TPI)	Bolt DIA (Inches)	Plain (Ft-Lb)	Plated (Ft-Lb)	Plain (Ft-Lb)	Plated (Ft-Lb)	Plated (Ft-Lb)
5/16-18	0.3125	17	13	25	18	22
3/8-16	0.3750	31	23	44	33	39
7/16-14	0.4375	49	37	70	52	63
1/2-13	0.5000	75	57	105	80	96
9/16-12	0.5625	110	82	155	115	139
5/8-11	0.6250	150	115	220	160	192
3/4-10	0.7500	265	200	375	280	340
7/8-9	0.8750	395	295	605	455	549
1-8	1.000	590	445	910	680	823
1 1/8-7	1.1250	795	595	1290	965	1167
1 1/4-7	1.2500	1120	840	1815	1360	1646
1 3/8-6	1.3750	1470	1100	2380	1780	2158
1 1/2-6	1.500	1950	1460	3160	2370	2865

Installation Overview

1. Determine that the mounting location for the EC4000 crane is at least 19" x 19" (48.3 x 48.3 cm).
2. Use the detail on the following page to drill .938" diameter holes into the mounting plate. Run tap on the threads of the base to be sure they are clean.
3. Use a crane or lifting device capable of lifting the weight of the Stellar crane. The Stellar EC4000 weighs approximately 1180 lbs (535 kg). **Note: cranes are shipped with rotation positioned at 180 degrees from normal stowed travel position.** This will allow for easy installation of the crane and permanent connection of all hydraulic and electrical components prior to repositioning into the crane saddle.
4. Connect straps or chain from the lifting device to the main boom of the Stellar EC4000.
5. Use four (4) 7/8" x 1.75" Grade 8 bolts and four (4) 7/8" Grade 8 flat washers.
6. Install a washer on each bolt.
7. Apply Loctite Thread locker #277 to the bolts.
8. Using the lifting device, lower the Stellar EC4000 just above the crane compartment and start the bolts. Have someone assist in leveling the crane.
9. Secure the crane using the mounting hardware provided. **Note: longer or shorter bolts may be required – recommended thread engagement into crane base is 0.75" – use grade 8, zinc plated bolts only.**
10. Torque the bolts to 455 ft-lbs.
11. Remove supporting crane.
12. Hook-up hydraulics and electrical using the schematics provided at the end of this chapter.

Note: If questions should arise during any portion of this installation, please contact Stellar Customer Service at (800) 321-3741.

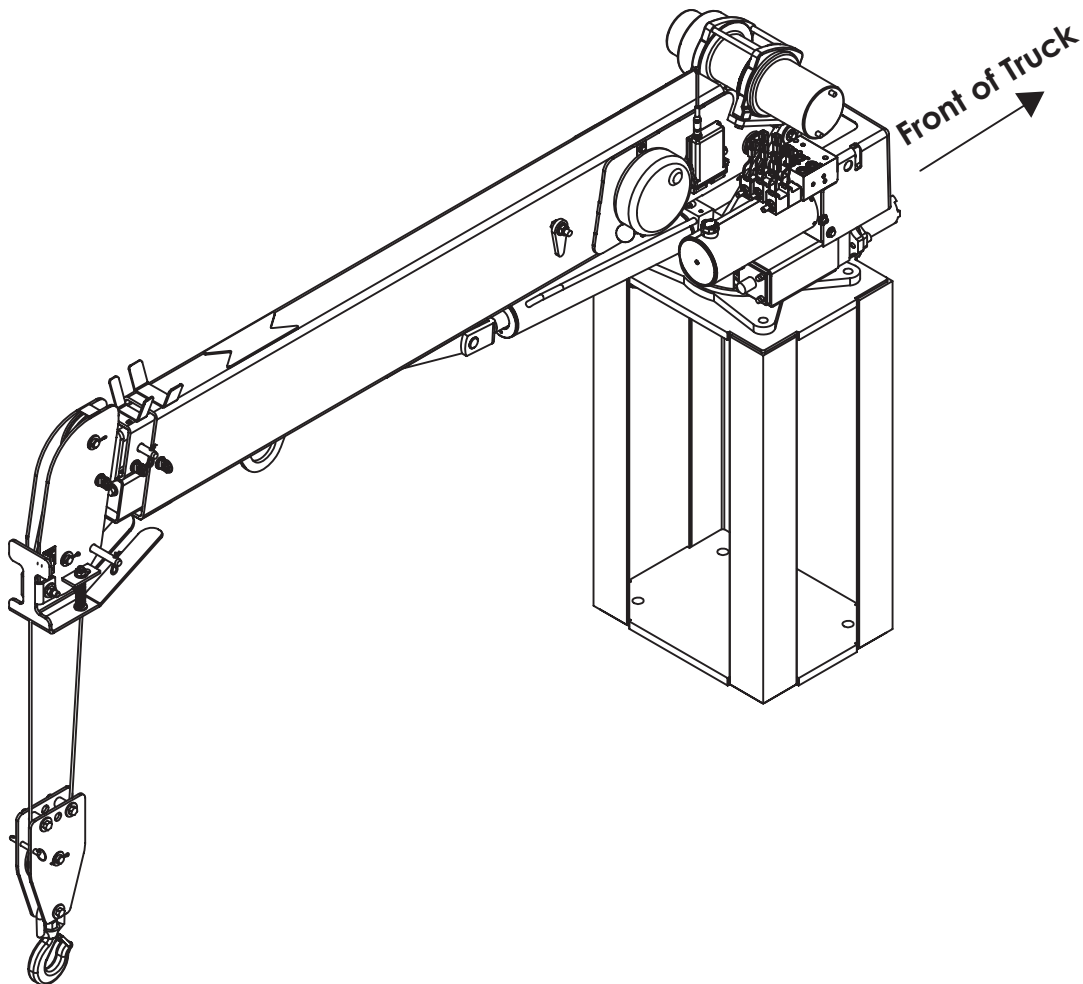

EC4000 Mounting Detail

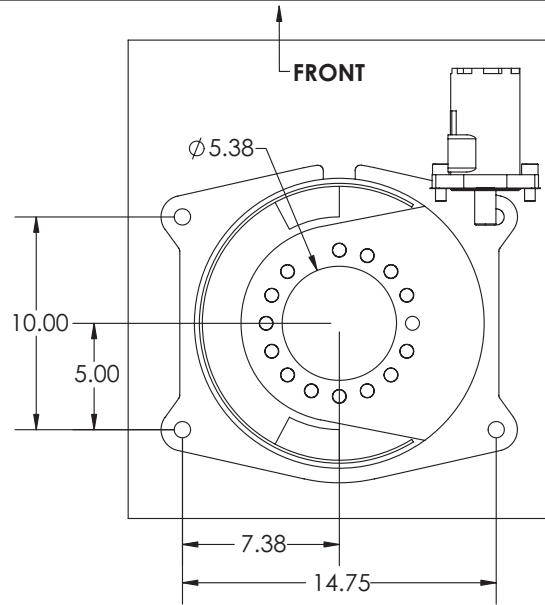

HOLE MOUNTING DETAIL

Flatbed Body Reinforcement

If it has been determined that the destination body won't support the crane with a fully rated load, the body must be reinforced. Use 1/4" fillet welds and an AWS qualified welder to proceed as shown in this drawing:

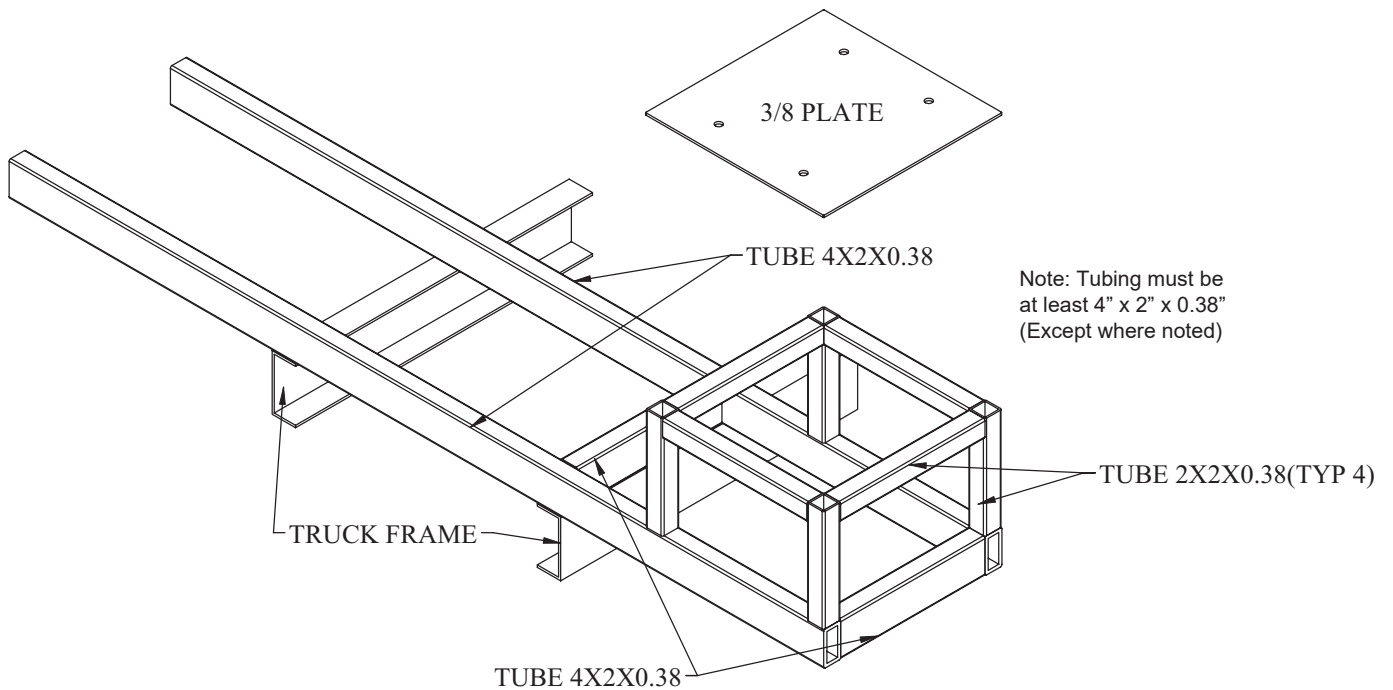

EC4000 Installation Drawing

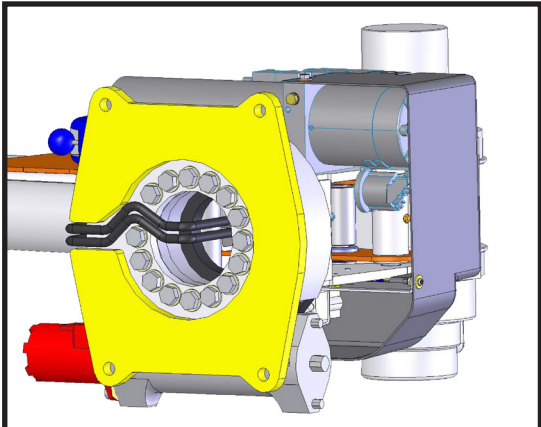
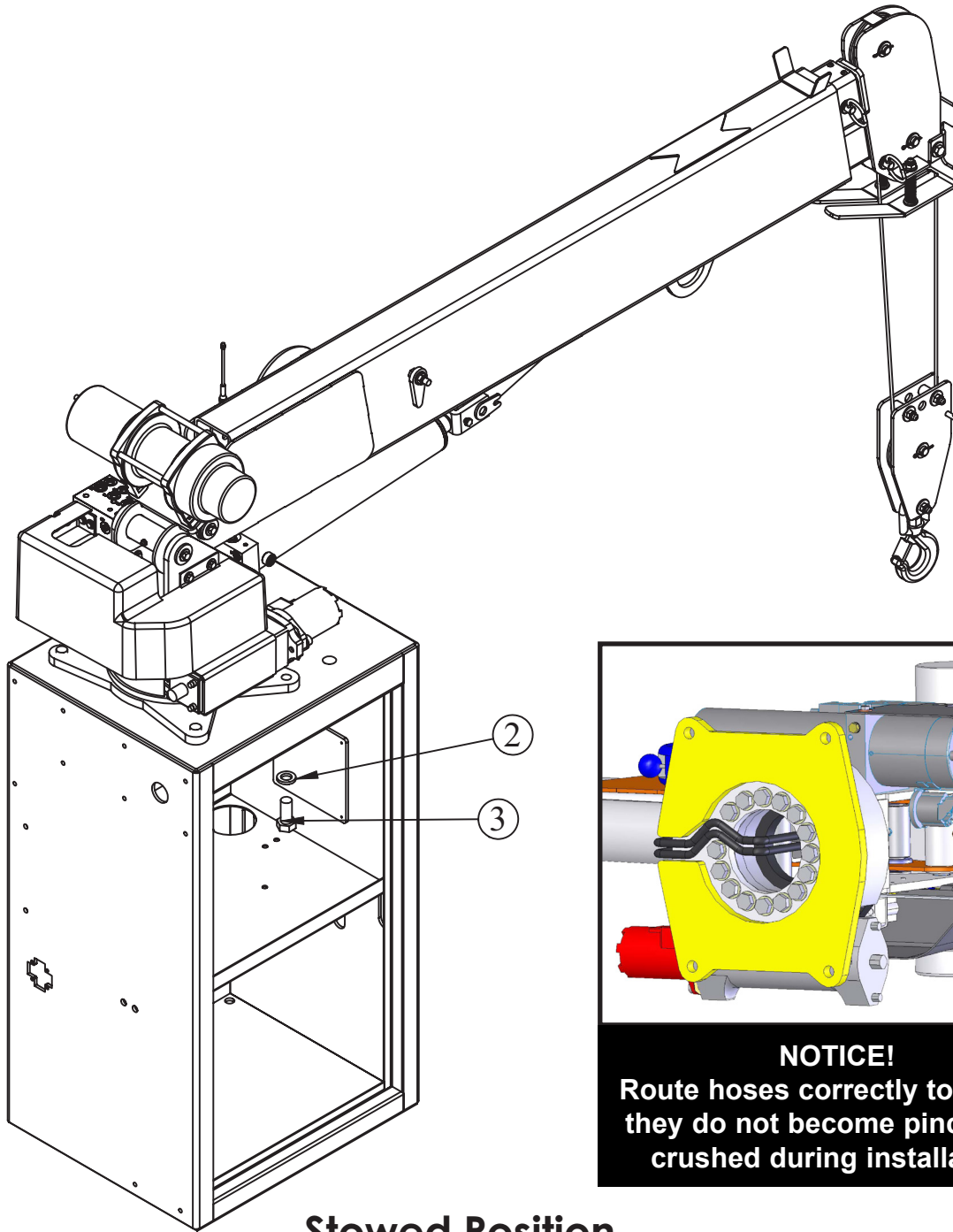

NOTICE!
Route hoses correctly to ensure they do not become pinched or crushed during installation.

Stowed Position

ITEM	PART No.	DESCRIPTION	QTY.
02	8648	WASHER 0.88 SAE FLAT YELLOW GR8	4
03	42985	CAP SCR 0.88-9X1.75 HHGR8	4

NOTE:
STABILITY DECAL P/N 16881 IS PART OF THIS KIT

Hydraulic Kit - PN 51282

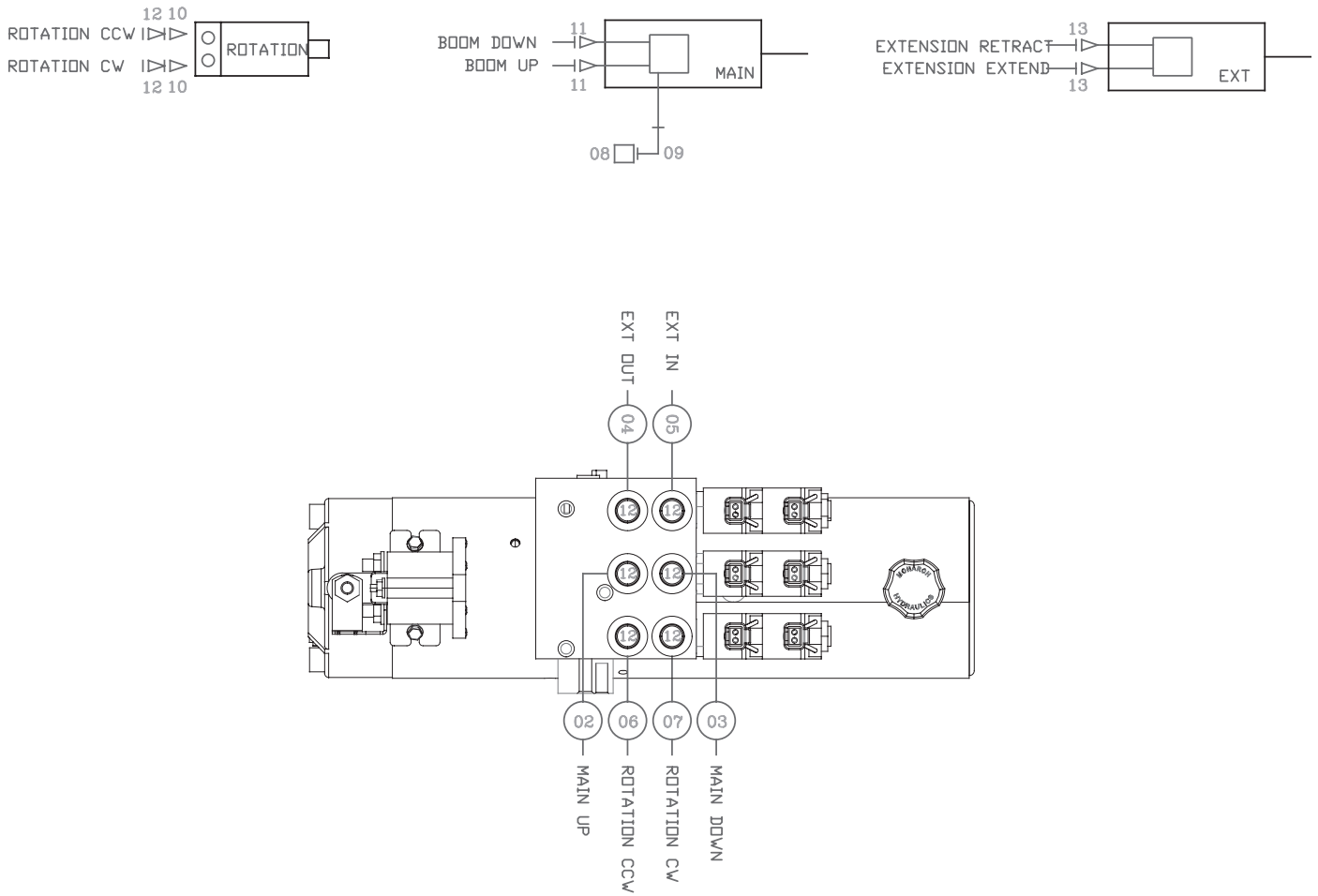

PN 51282

13	C5572	FTG 4-4 MFS-MADR B 45	2
12	C4922	FTG 4-6 MFS-MDR B STRAIGHT	8
11	D1291	FTG 4-4 MFS-MDR B STRAIGHT	2
10	C1111	FTG 10-6 MDR B-FDR B STRAIGHT REDUCER	2
09	3861	FTG 6-6 MADRB-FDR B 90	1
08	70491	SWITCH PRES OVERLD CF-11C-2300R/wD	1
07	42984	HOSE-HYD .25X 43	1ref
06	42982	HOSE-HYD .25 X 42	1ref
05	43847	HOSE-HYD .25 X 20	1ref
04	42981	HOSE-HYD .25 X 19	1ref
03	42983	HOSE-HYD .25 X 23	1ref
02	42980	HOSE-HYD .25 X 22	1ref
01	42800	HOSE KIT 3315 CRANE (incl:2-11)	1
ITEM	PART No.	DESCRIPTION	QTY

Valve Bank Drawing

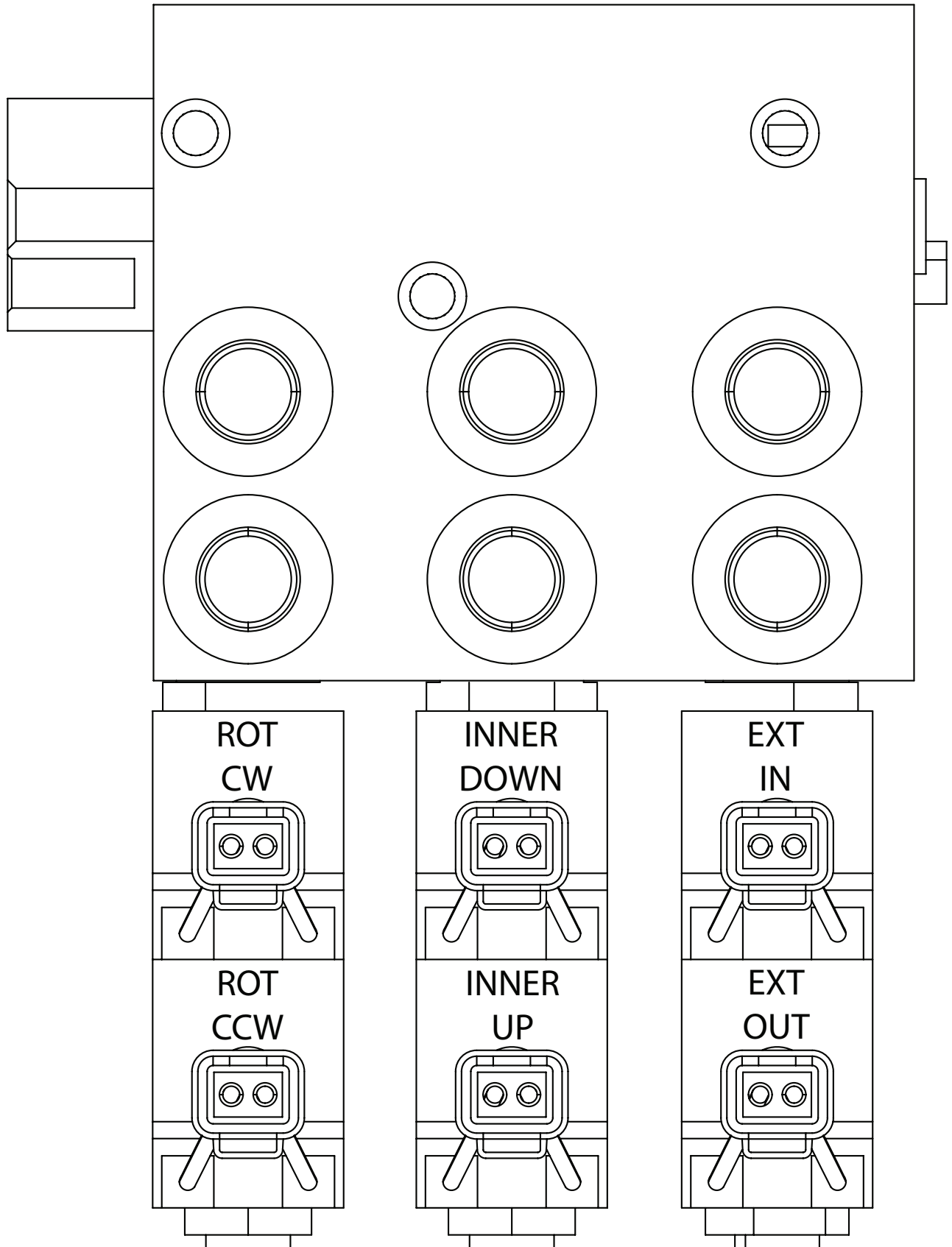

This page left intentionally blank.

Control Kit - PN 42804 Parts List

PN 42804			
ITEM	PART	DESCRIPTION	QTY
01	39784	RADIO CNTRL ASM 5 FCTN ON/OFF	1
02	—	RECEIVER-RADIO (PART OF 1)	REF
03	67894	TRANSMITTER-RADIO (PART OF 1)	1
04	42805	WIRE HARNESS EC3200	1
05	17771	SWITCH PUSH BUTTON 9216-03	1
06	47410	SWITCH MOM SPST 20A	1
07	47409	COVER SWITCH EC3200	1
08	47092	WIRE HARNESS EC3200 CONTROLLER	REF
09	72602	CORD REEL ASM 15/20/21 FT CRANE	REF
10	35105	SWITCH LIMIT (NO) ROLLER LVR LT BRKT	1
REV. C			

NOTES:

P/N 47092 INCLUDES HARNESS & WINCH CONTROLLER

Control Kit (24V Option) - PN 67932

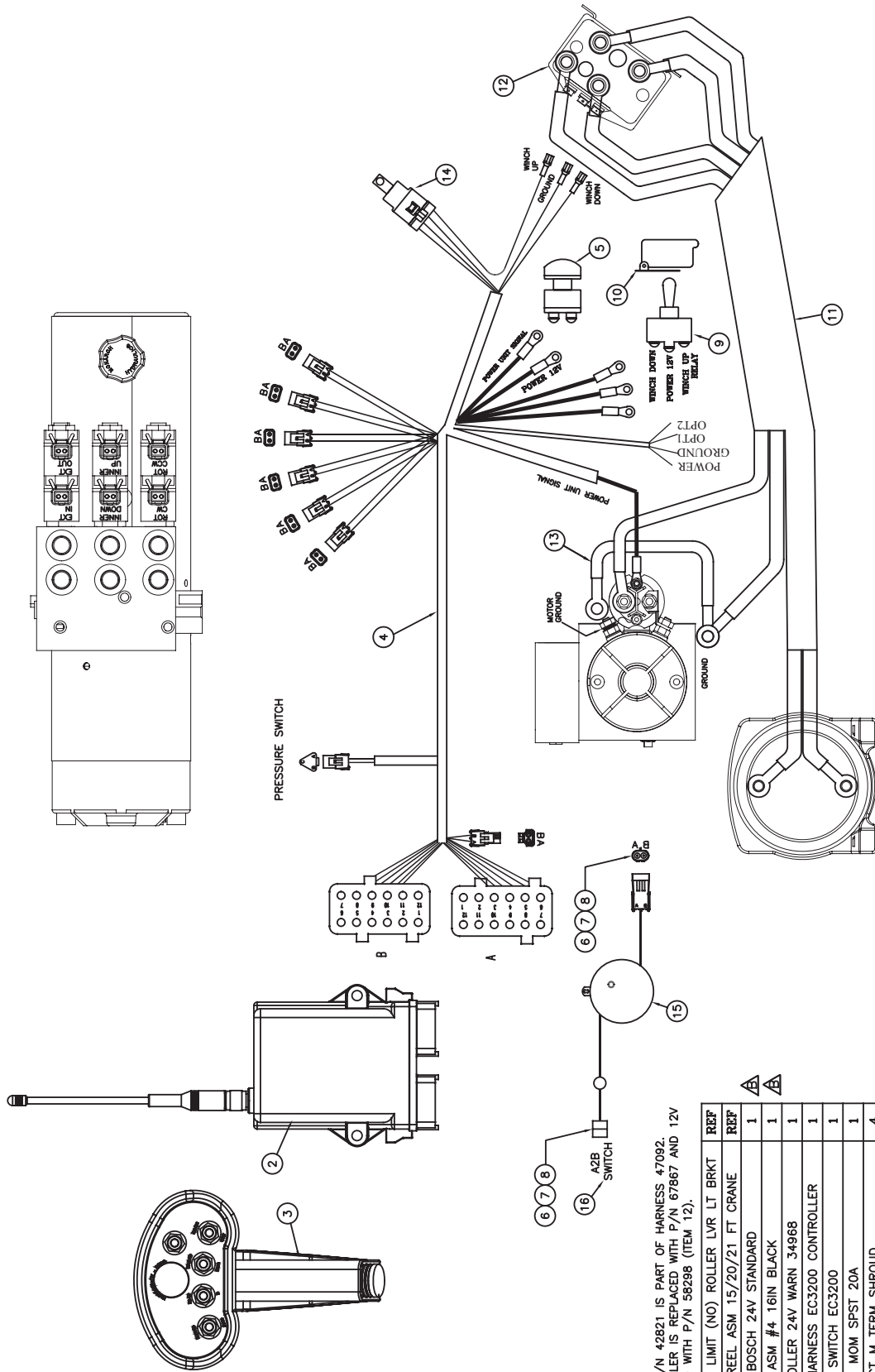

NOTE: 12V CONTROLLER P/N 42821 IS PART OF HARNESS 47092.
 FOR 24V OPTION CONTROLLER IS REPLACED WITH P/N 67867 AND 12V
 RELAY MUST BE REPLACED WITH P/N 58298 (ITEM 12).

ITEM	PART No.	DESCRIPTION	QTY
16	35105	SWITCH LIMIT (NO) ROLLER LVR LT BRKT	REF
15	72602	CORD REEL ASM 15/20/21 FT CRANE	REF
14	58298	RELAY BOSCH 24V STANDARD	1
13	36176	CABLE ASM #4 16IN BLACK	1
12	67867	CONTROLLER 24V WARN 34968	1
11	47092	WIRE HARNESS EC3200 CONTROLLER	1
10	47409	COVER SWITCH EC3200	1
09	47410	SWITCH MOM SPST 20A	1
08	9756	CONTACT M TERM SHROUD	4
07	6384	CABLE SEAL 18-20 PACKARD 39000	4
06	9752	CONNECT 2 PIN SHROUD PACKARD	2
05	17771	SWITCH PUSH BUTTON 9216-03	1
04	42805	WIRE HARNESS EC3200	1
03	67894	TRANSMITTER-RADIO (PART OF 1)	REF
02		RECEIVER-RADIO (PART OF 1)	REF
01	39784	RADIO CNTRL ASM 5 FCN ON/OFF	1

EC4000 Wiring Diagram

NOTICE Operating the crane without the truck engine running could allow the truck battery to be discharged below levels required for starter cranking power.

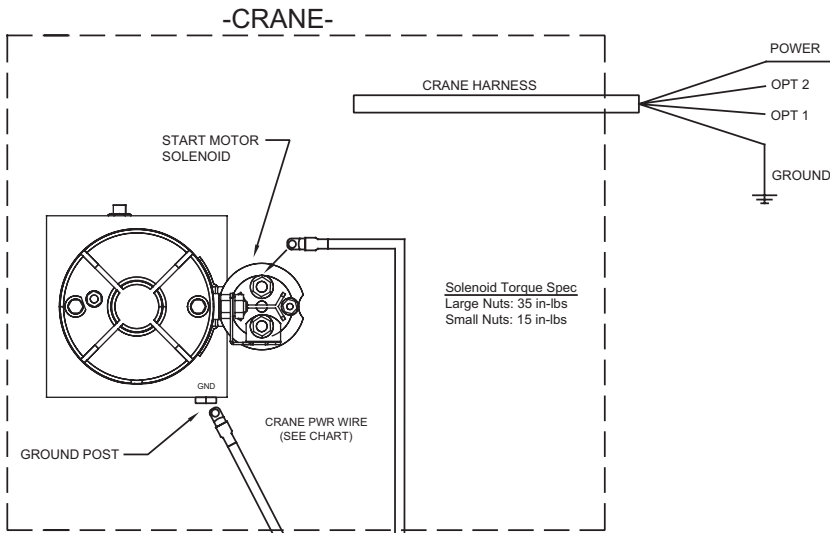
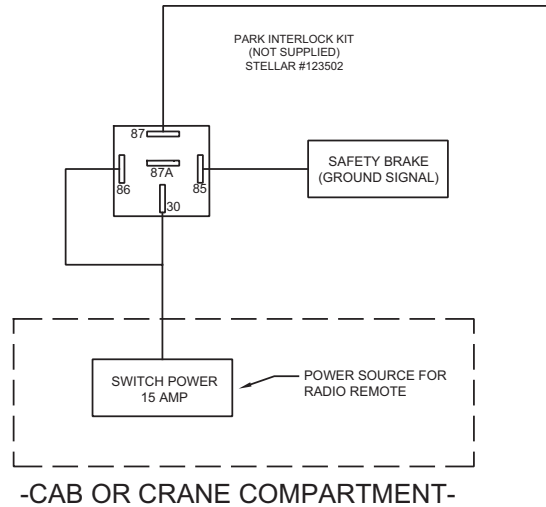

Solenoid Torque Spec
Large Nuts: 35 in-lbs
Small Nuts: 15 in-lbs

WIRE & FUSE SIZING:		
CRANE:	WIRE GA:	FUSE:
EC3200	2GA	250A
EC4000	2GA	250A
EC5000	2GA	250A
EC6000	1/0	300A

FUSE HOLDER
#32523
FUSE
(SEE CHART)
(STELLAR SUPPLIED)

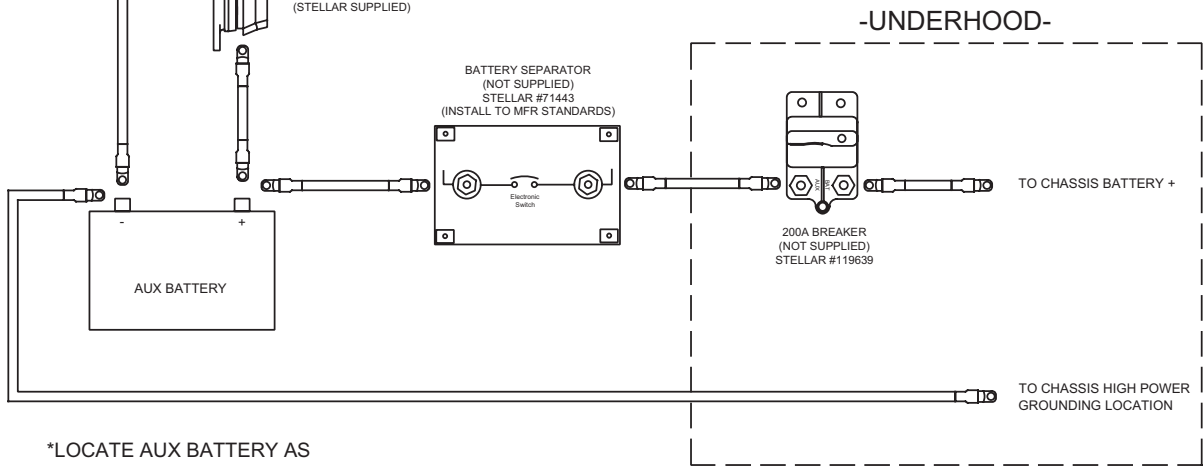

*LOCATE AUX BATTERY AS CLOSE TO CRANE AS POSSIBLE

Electrical Circuit Grounding

When installing the crane, always locate a good source for grounding the circuit. A majority of electrical failures are due to poor grounding. Poor grounding can cause intermittent operation of the equipment, electrical component failures and cause the equipment to not operate at all.

Chassis manufacturers usually will have a ground strap which ties into the truck frame from the battery, but it is always a good idea to check each individual model to verify where the ground is located. Never use the mechanic body as a ground source. Make sure the electrical grounds are routed to either the chassis frame rail or the chassis's main grounding source.

Stellar provides a stud (PN 40992) for grounding the crane to the chassis frame rail:



Inside Frame Rail

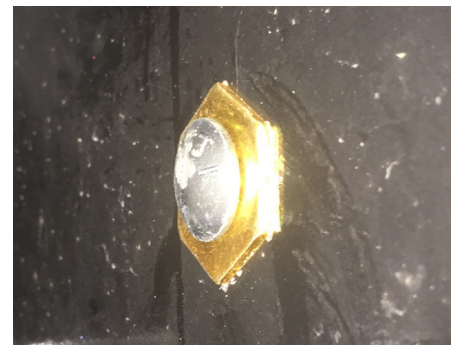

Outside Frame Rail

• Drill the hole to the frame rail in accordance with the chassis body builder's guide.

⚠ WARNING

- Hole size: 21/64"
- The hole location should allow for the shortest length of ground wire while keeping enough slack for flexibility.
- Be sure to grind the frame rail around the hole to ensure a proper ground connection.
- Frame rail thickness may require additional flat washers (as shown).
- Use an electrical coating on hardware to prevent corrosion.

Stability Procedure

Definition of Stability for the Stellar Telescopic Crane Products:

A truck is stable until the load cannot be lifted off the ground with the winch, without tipping over the truck. Every Stellar crane installed must be tested for stability to determine the actual load capacity of the final truck package. The actual test data must be recorded and supplied with the truck at the time of in-service and should be kept with the truck at all times. The following procedure will test the truck package for stability and will provide a stability capacity chart. The load limit information shown on the stability capacity chart is formulated on 85% tipping.

Set Up:

1. Locate the truck on a test course in position for loading and engage travel brakes.
2. Set stabilizers so that they make contact with firm, level footings.
3. Operate the crane under partial load to assure operator proficiency and proper machine function.

EC4000-20ft Version Stability Data

Max Horizontal Reach: 240" (From the center of rotation to boom tip)

Stability Test Weight: 945 lbs.

Test Procedure

1. Rotate the crane into Zone 1 position.
2. With the crane fully retracted and the boom horizontal, winch the test weight off the ground.
Note: Keep weight within six inches of the ground at all times.
3. Extend the boom outward until full extension has been reached or until the truck becomes unstable (Again, use the winch to keep the weight within six inches of the ground.)
4. If the boom goes full extension without becoming unstable, the crane is termed stable for this zone and 100% can be written in the Zone 1 data box.
5. If the truck becomes unstable prior to going full extension, retract the boom until the truck becomes stable and measure the horizontal reach in this position (center of rotation to boom tip). This is the stable horizontal reach for this zone. Stable horizontal reach divided by Maximum horizontal reach multiplied by 100 equals the percentage of rated capacity for this zone. Use the following formula to determine the percentage of rated capacity:

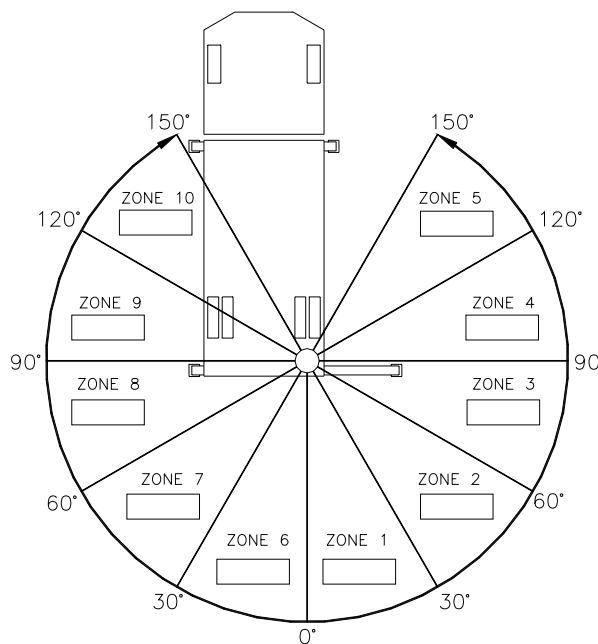

$$\frac{\text{Stable Horizontal Reach}}{\text{Max Horizontal Reach}} \times 100 = \text{Percentage of Rated}$$

6. Record this number in the data box for Zone 1. This is the revised capacity due to stability for this zone.
7. Repeat this procedure for each zone until the worksheet is completed.
8. This is the revised capacity based on stability of this package.

Decal Kit Placement - PN 51286

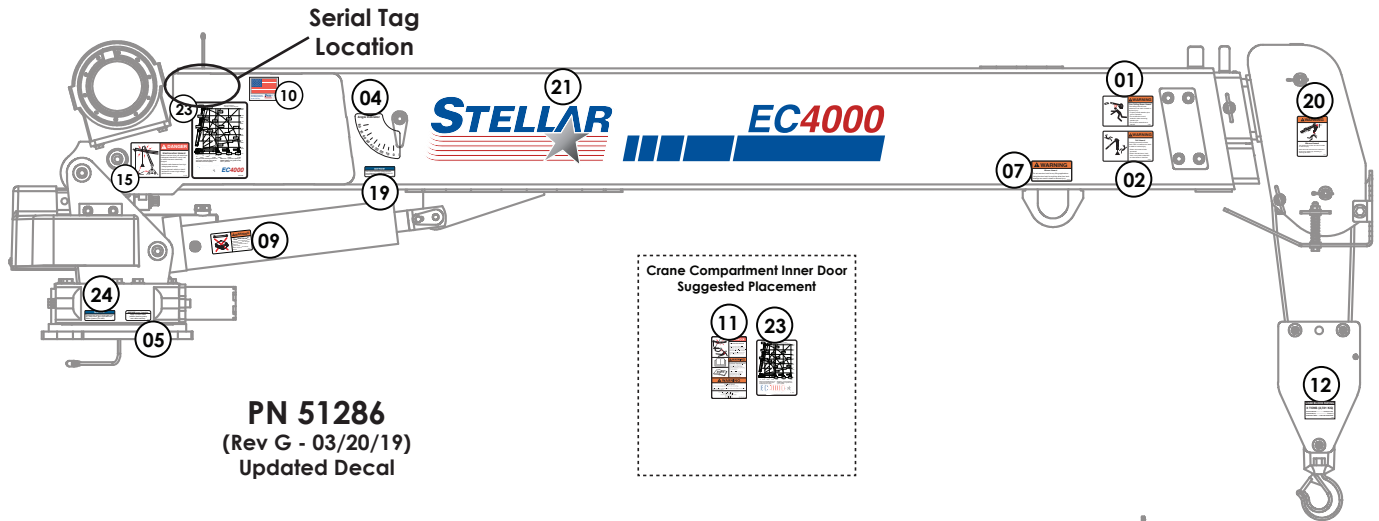

PN 51286
(Rev G - 03/20/19)
Updated Decal

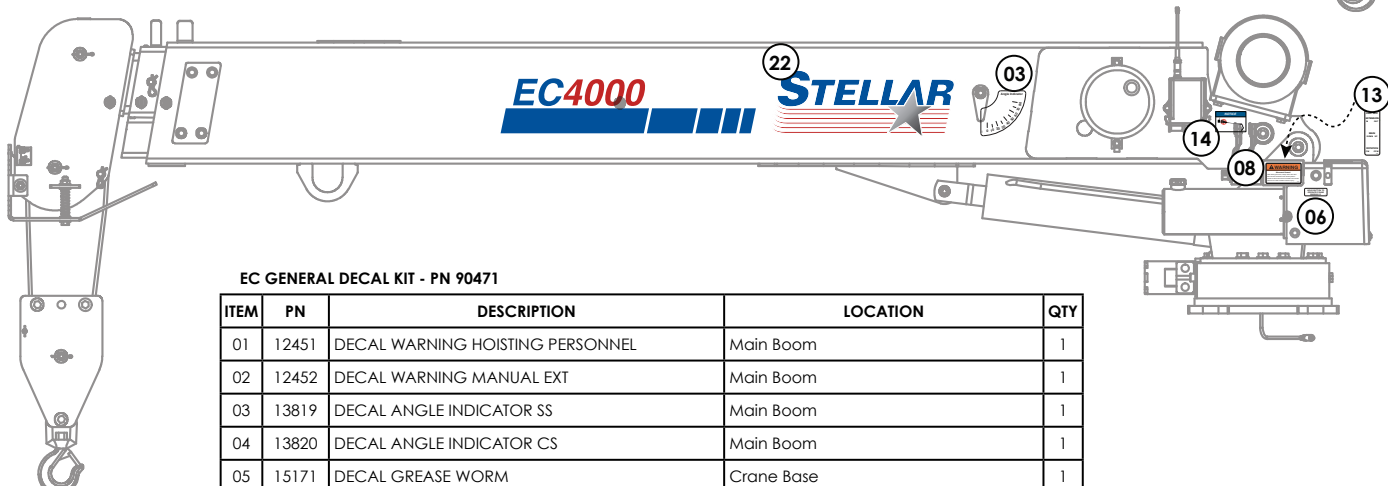

EC GENERAL DECAL KIT - PN 90471

ITEM	PN	DESCRIPTION	LOCATION	QTY
01	12451	DECAL WARNING HOISTING PERSONNEL	Main Boom	1
02	12452	DECAL WARNING MANUAL EXT	Main Boom	1
03	13819	DECAL ANGLE INDICATOR SS	Main Boom	1
04	13820	DECAL ANGLE INDICATOR CS	Main Boom	1
05	15171	DECAL GREASE WORM	Crane Base	1
06	18472	DECAL MANUAL OPERATION	Power unit cover	1
07	24712	DECAL WARNING STOW HOOK	Crane Boom above stow hook	1
08	25159	DECAL WARNING MANUAL OVERRIDES	Valve Bank	1
09	28256	DECAL WARNING OVERLOAD DEVICE	Main Cylinder	1
10	35234	DECAL STELLAR MADE IN THE USA	Main Boom	1
11	93936	DECAL SAFETY & SERVICE MECH BODY DOOR	Crane Compartment	1
12	116438	DECAL SNATCH BLOCK 3 TON	Snatch Block	1
13	42820	DECAL VB CONTROL EC SERIES	On top of valve bank	1
14	73929	DECAL PRESSURE WASH	Main Boom	1
15	C1179	DECAL DANGER ELECTROCUTION SMALL	Main Boom	1
16*	C4545	DECAL DANGER ELECTROCUTION LARGE	Four corners of the body/chassis	4
17*	C5910	DECAL STELLAR 4x9.5	Suggested: Rear body/tailgate	1
18*	C5911	DECAL STELLAR 2x4.5	Suggested: Side corners of body	3

EC4000-20 DECAL KIT - PN 90486

ITEM	PN	DESCRIPTION	LOCATION	QTY
19	15172	DECAL ASME/ANSI B30.22/B30.5	Main Boom	1
20	12300	DECAL WARNING TWO BLOCKING	Crane Horse Head	1
21	101063	DECAL IDENTIFICATION EC4000-20 LEFT	Main Boom	1
22	101064	DECAL IDENTIFICATION EC4000-20 RIGHT	Main Boom	1
23	51283	DECAL CAPACITY EC4000-20	Main Boom and Crane Compartment	2
24	9188	DECAL ROTATE/GREASE	Crane Base	1
25*	C4795	DECAL WARNING STABILIZERS	Stabilizers	2

*Not Shown

Chapter 3 - Assembly Drawings

Base Assembly - PN 71896

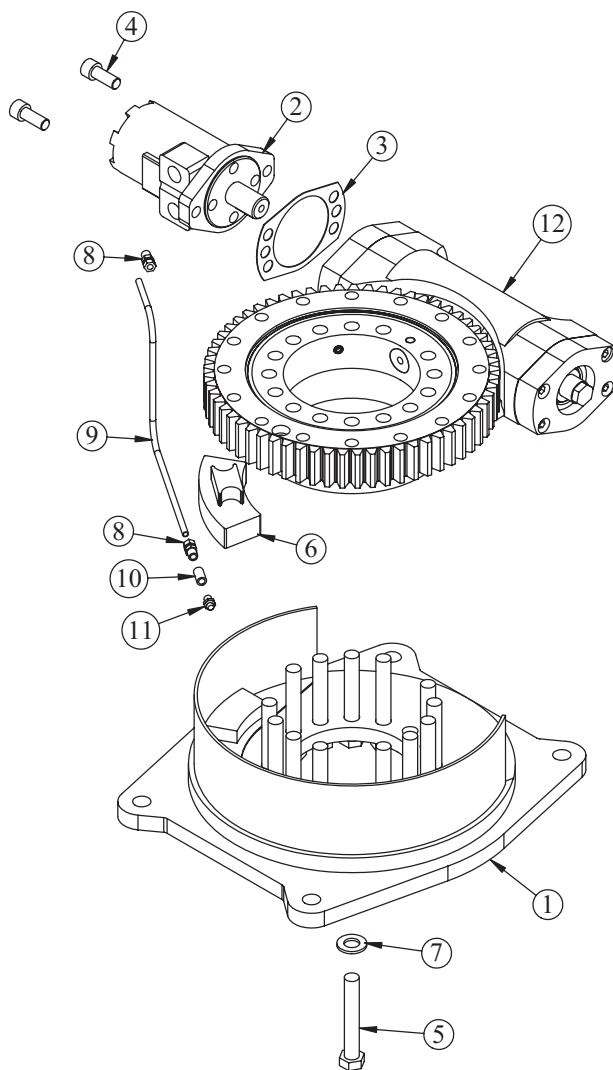

PN 71896

ITEM	PART	DESCRIPTION	QTY.
1	50055	BASE EC4000	1
2	D1204	ROTATION MOTOR 5520	1
3	21151	GASKET MOTOR 008-10056-1	1
4	D1307	CAP SCR 0.50-13X1.25 SHGR8 W/ RED PATCH	2
5	16655	CAP SCR 0.63-11X4.00 HHGR9	14
6	71897	STOP SLIDING EC4000/EC5000 KINEMATICS	1
7	16733	WASHER 0.63 FLAT GR9	14
8	D1345	FTG CPRSN 0.12NPT/0.25 TUBE	2
9	D1810	TBE AIR SAEJ844 TYPE A .25 (RM)	2.5
10	22161	FTG 2-2 FP-FP COUPLER STRAIGHT BRASS	1
11	56589	ZERK 1/8 NPT STRAIGHT LONG THREAD	1
12	69735	BEARING SWING DRIVE 9 IN EC4000/5000 KINEMATICS	1

MOTOR GASKET SHOWN AS REFERENCE ONLY

Mast Assembly - PN 50368

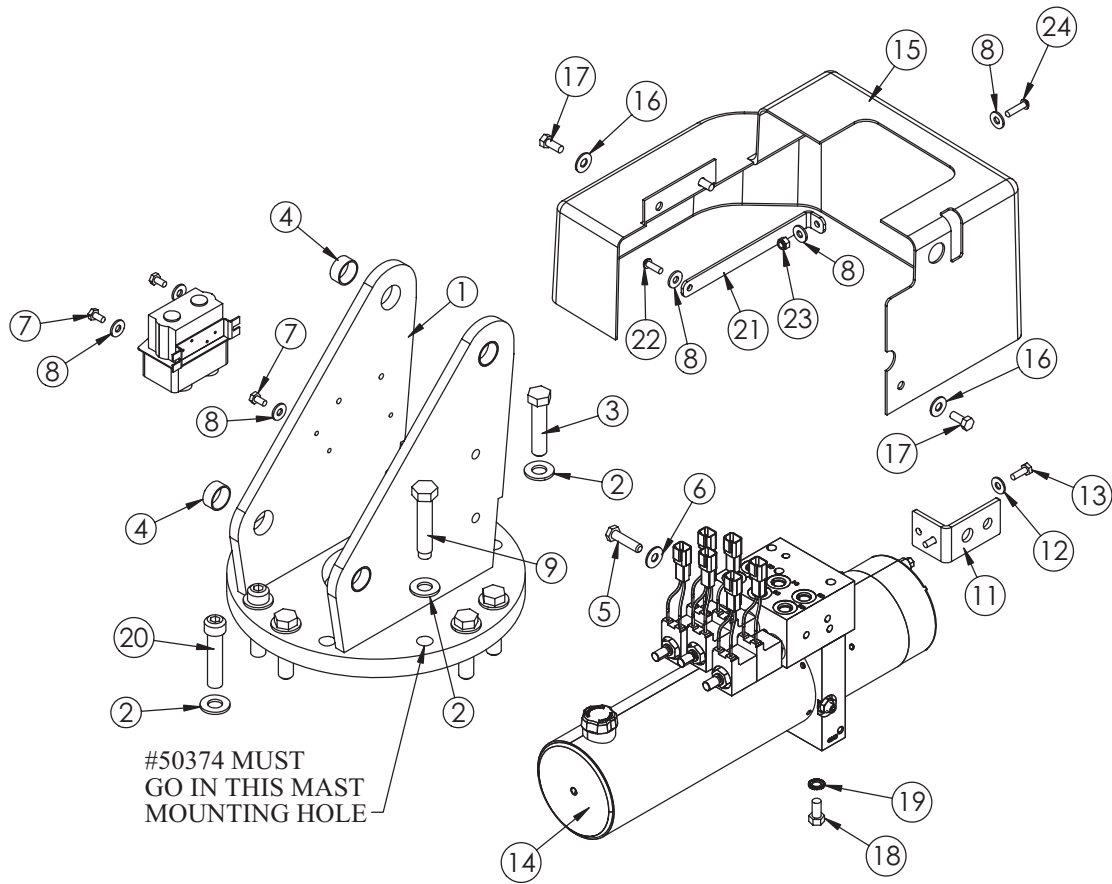

PN 50368

ITEM	PART	DESCRIPTION	QTY.
1	50369	MAST EC4000	1
2	C5902	WASHER 0.63 SAE FLAT YELLOW GR8	12
3	50375	CAP SCR 0.63-11X2.75 HHGR8	9
4	20362	BUSHING IGUS GFI-1618-08	4
5	0345	CAP SCR 0.38-16X1.50 HHGR5	2
6	0346	WASHER 0.38 FLAT	2
7	0478	CAP SCR 0.25-20X0.50 HHGR5	3
8	D0917	WASHER 0.25 FLAT SS	6
9	50374	CAP SCR 0.63-11X3.09 MOD EC4000	1
11	47411	BRKT OVERRIDE BUTTON EC3200	1
12	0340	WASHER 0.25 FLAT	2
13	0479	CAP SCR 0.25-20X0.75 HHGR5	2
14	42513	POWER UNIT 12V EC3200	1
15	44475	COVER EC3200 HDPE	1
16	0343	WASHER 0.31 USS FLAT ZINC	3
17	0420	CAP SCR 0.31-18X0.75 HHGR5	3
18	0492	CAP SCR 0.38-16X0.75 HHGR5	1
19	5870	WASHER 0.38 STAR EXTERNAL	1
20	51281	CAP SCR 0.63-11X2.75 SHSS	2
21	51896	BRKT COVER EC CRANES	1
22	C6021	CAP SCR 0.25-20X0.75 BTNHD SS	1
23	30659	NUT 0.25-20 HH NYLOC SS	1
24	C6022	CAP SCR 0.25-20X1.00 BTNHD SS	1

NOTE:
WINCH CONTROLLER
SHOWN FOR REFERENCE ONLY

Power Unit Assembly - PN 42513

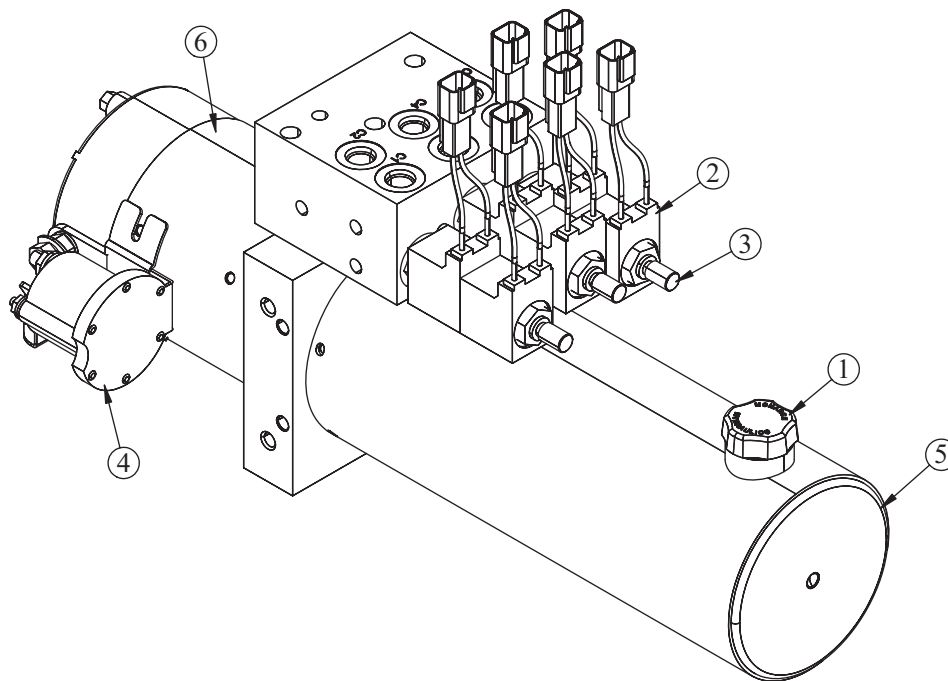

PN 42513

ITEM	PART No.	DESCRIPTION
01	44025	FILL CAP - HYDRAULIC RESERVOIR
02	44027	VALVE COIL EC3200 POWER UNIT
03	44028	VALVE CARTRIDGE EC3200 UNIT
04	44030	SOLENOID START EC3200 P-UNIT

MANUFACTURER: BUCHER HYDRAULICS		
ITEM	PART No.	DESCRIPTION
05	44026	RSRVR EC3200 POWER UNIT
06	44029	MOTOR 12V EC3200 POWER UNIT
07	56648	O-RING PWR UNIT RESERVOIR 3315/4420/5520

MANUFACTURER: MTE HYDRAULICS		
ITEM	PART No.	DESCRIPTION
05	99353	RSRVR EC3200 POWER UNIT
06	100734	MOTOR 12V EC3200 POWER UNIT
07	125086	ORING RSRVR EC3200 POWER UNIT

Mast Assembly (24V Option) - PN 67930

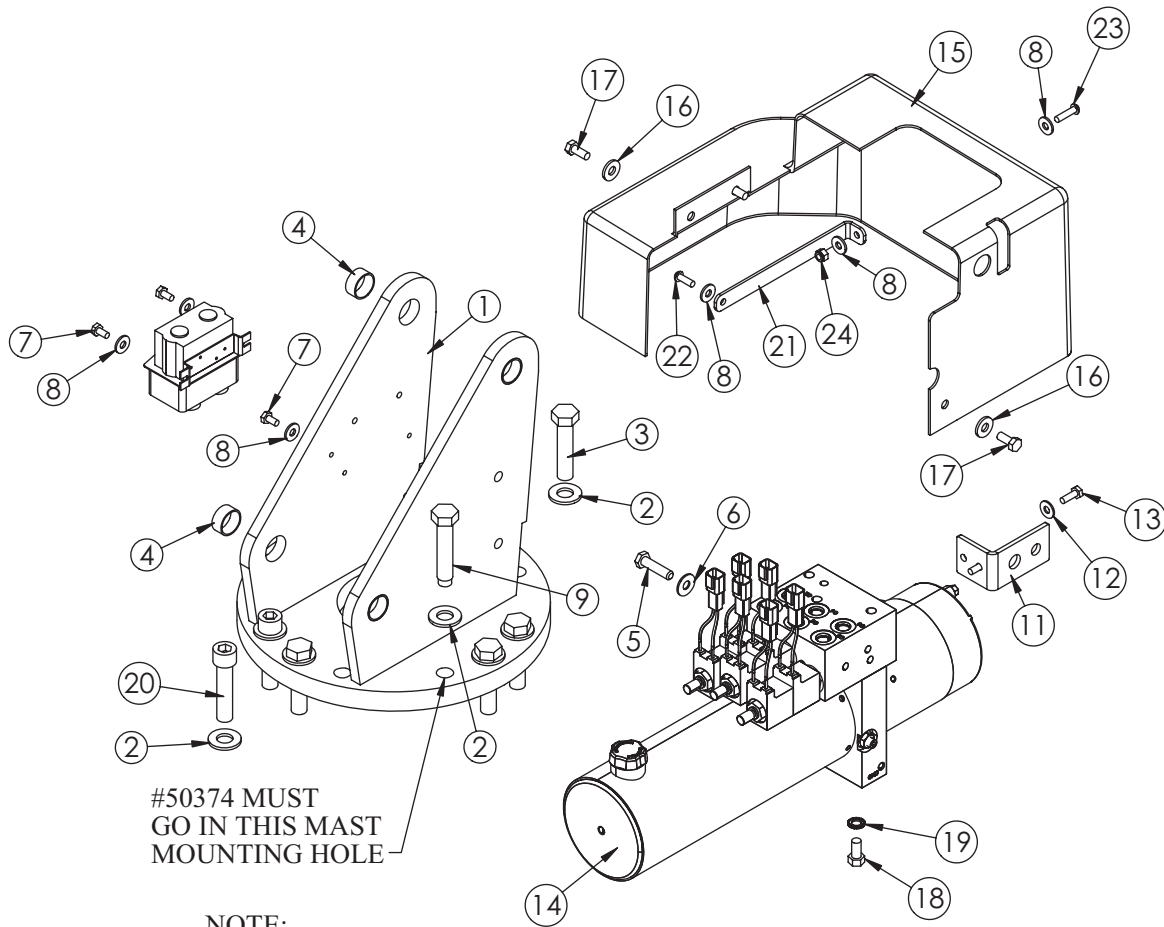

NOTE:
WINCH CONTROLLER
SHOWN FOR REFERENCE ONLY

PN 67930

ITEM	PART	DESCRIPTION	QTY.
1	50369	MAST EC4000	1
2	C5902	WASHER 0.63 SAE FLAT YELLOW GR8	12
3	50375	CAP SCR 0.63-11X2.75 HHGR8	9
4	20362	BUSHING BPC16DXR08 1.00X.50	4
5	0345	CAP SCR 0.38-16X1.50 HHGR5	2
6	0346	WASHER 0.38 FLAT	2
7	0478	CAP SCR 0.25-20X0.50 HHGR5	3
8	D0917	WASHER 0.25 FLAT SS	6
9	50374	CAP SCR 0.63-11X3.09 MOD EC4000	1
11	47411	BRKT OVERRIDE BUTTON EC3200	1
12	0340	WASHER 0.25 FLAT	2
13	0479	CAP SCR 0.25-20X0.75 HHGR5	2
14	67931	POWER UNIT 24V EC CRANES	1
15	44475	COVER EC3200 HDPE	1
16	0343	WASHER 0.31 USS FLAT ZINC	3
17	0420	CAP SCR 0.31-18X0.75 HHGR5	3
18	0492	CAP SCR 0.38-16X0.75 HHGR5	1
19	5870	WASHER 0.38 STAR EXTERNAL	1
20	51281	CAP SCR 0.63-11X2.75 SHSS	2
21	51896	BRKT COVER EC CRANES	1
22	C6021	CAP SCR 0.25-20X0.75 BTNHD SS	1
23	C6022	CAP SCR 0.25-20X1.00 BTNHD SS	1
24	30659	NUT 0.25-20 HH NYLOC SS	1

Main Boom Assembly - PN 50509

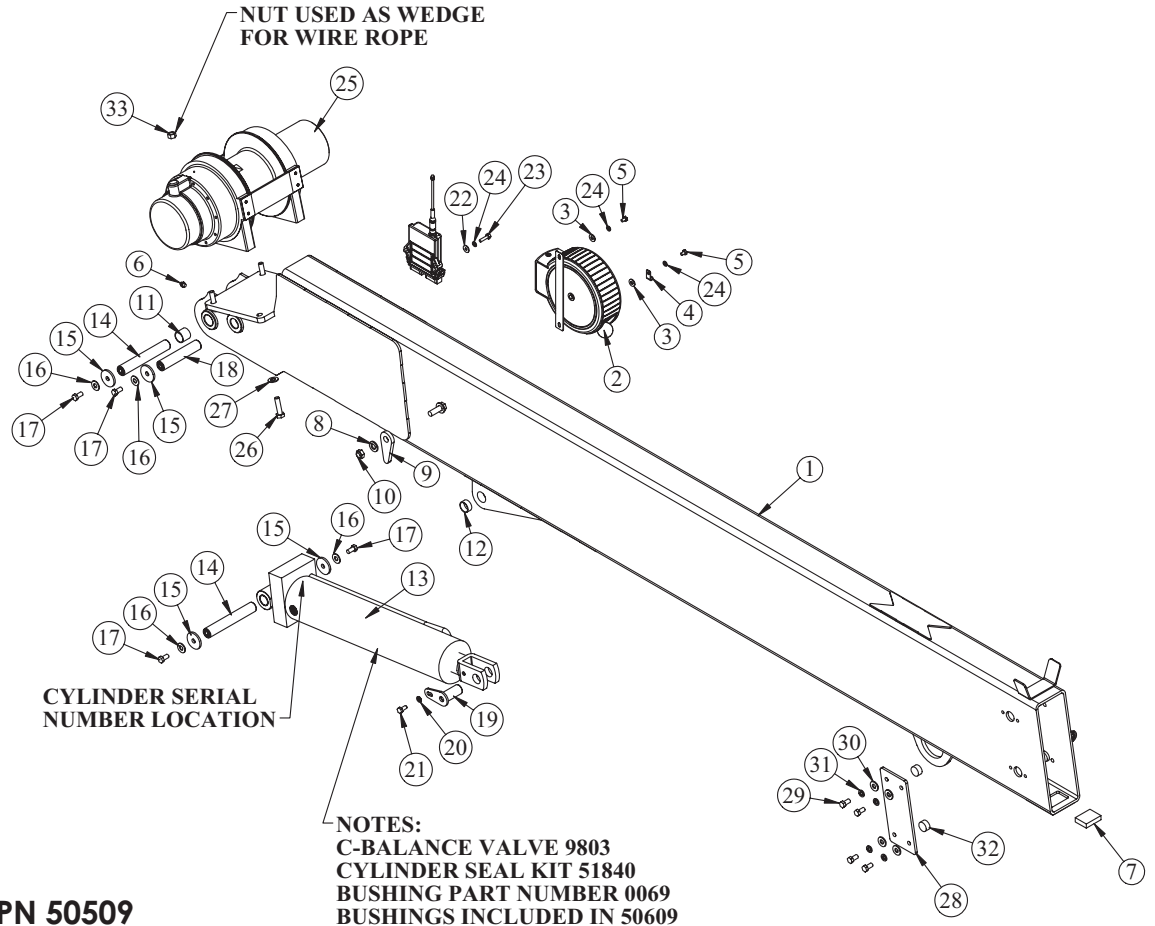

PN 50509

NOTES:
C-BALANCE VALVE 9803
CYLINDER SEAL KIT 51840
BUSHING PART NUMBER 0069
BUSHINGS INCLUDED IN 50609

ITEM	PART	DESCRIPTION	QTY.
1	50510	INNER BOOM EC5000	1
2	72602	CORD REEL ASM 15/21 FT CRANE	1
3	0340	WASHER 0.25 FLAT	2
4	C5606	CLAMP 0.25 BLK VINYL	1
5	43845	CAP SCR 0.25-20X0.38 HHGR5	2
6	c1592	ZERK 1/8 NPT STRAIGHT	1
7	42508	WEAR PAD 0.50X1.50X2.00	1
8	D0790	WASHER 0.50 FLAT GR8	4
9	13815	PLATE ANGLE INDICATR PC BLACK	2
10	C6106	NUT 0.50-13 HHGR5 NYLOC	2
11	0069	BUSHING QSI-1618-16	2
12	20362	BUSHING BPC16DXR08 1.00X.50	1
13	50609	CYLINDER 4.00X13.00	1
14	11688CR	PIN 1.00X6.31D&T ZC	2
15	9320	PIN CAP 0.44X1.75X0.19 YZ	6
16	C6353	WASHER 0.38 FLAT GR8	6
17	9843	CAP SCR 0.38-16X0.75 HHGR8	6
18	42516CR	PIN 1.00X5.13 D&T ZC	1
19	42517CR	PIN TEAR DROP 1.00X2.19 ZC	1
20	5591	WASHER 0.31 SAE FLAT YELLOW GR8	1
21	53521	CAP SCR 0.31-18X0.75 HHGR8	1
22	D0917	WASHER 0.25 FLAT SS	2
23	0480	CAP SCR 0.25-20X1.00 HHGR5	2
24	0521	WASHER 0.25 LOCK	4
25	50226	WINCH 2500DC WARN	1
26	50111	CAP SCR 12MMX45MM HHGR8	4
27	42788	WASHER 0.44 SAE FLAT YELLOW GR8	4
28	51168	COVER WEAR PAD EC5000 PC WHITE	2
29	0492	CAP SCR 0.38-16X0.75 HHGR5	8
30	0346	WASHER 0.38 USS FLAT	8
31	0523	WASHER 0.38 LOCK	8
32	51169	WEAR PAD 0.50X1.00 RND	4
33	0536	NUT 0.44-14 HHGR5	1

RADIO RECEIVER SHOWN AS REFERENCE ONLY

Main Boom Assembly (24V Option) - PN 67868

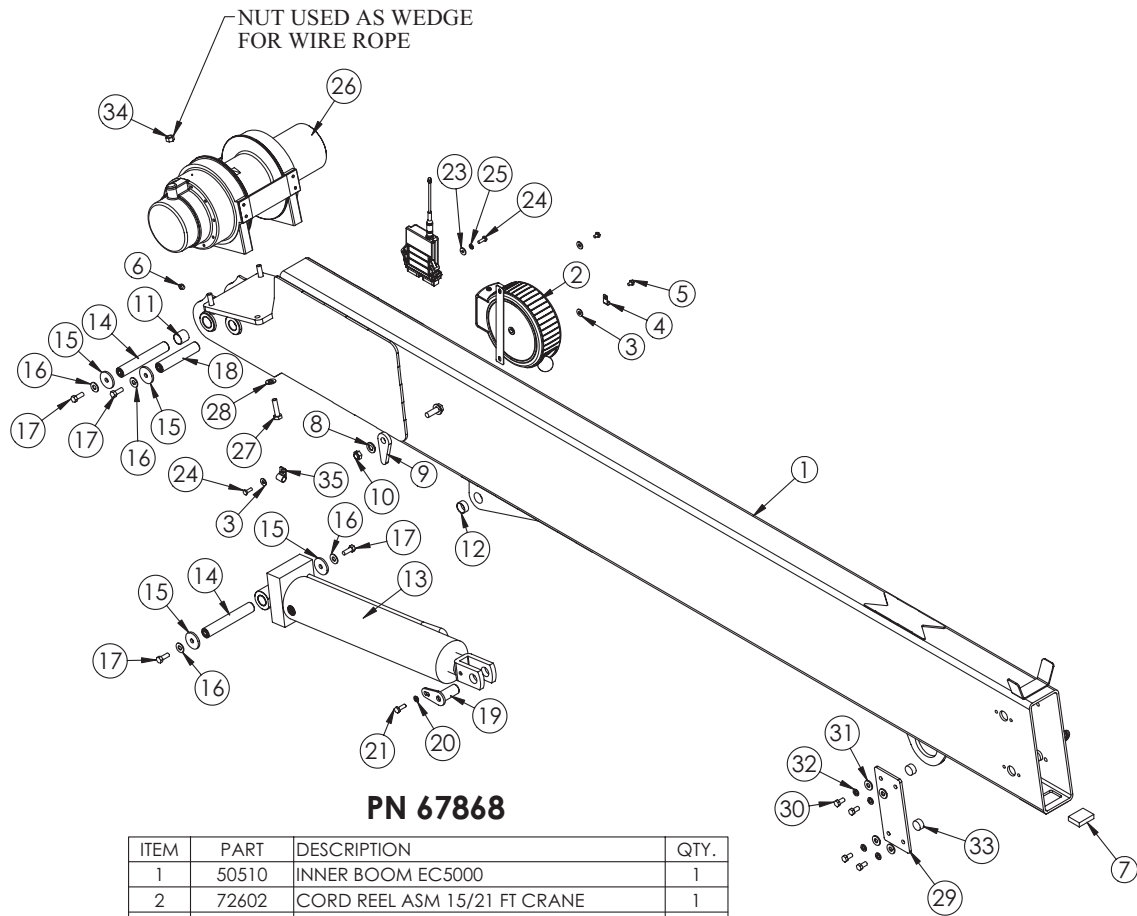

PN 67868

ITEM	PART	DESCRIPTION	QTY.
1	50510	INNER BOOM EC5000	1
2	72602	CORD REEL ASM 15/21 FT CRANE	1
3	0340	WASHER 0.25 FLAT	3
4	C5606	CLAMP 0.25 BLK VINYL	1
5	43845	CAP SCR 0.25-20X0.38 HHGR5	2
6	c1592	ZERK 1/8 NPT STRAIGHT	1
7	42508	WEAR PAD 0.50X1.50X2.00	1
8	D0790	WASHER 0.50 FLAT GR8	4
9	13815PC	PLATE ANGLE INDICATOR	2
10	C6106	NUT 0.50-13 HHGR5 NYLOC	2
11	0069	BUSHING QSI-1618-16	2
12	20362	BUSHING BPC16DXR08 1.00X.50	1
13	50609	CYLINDER 4.00X13.00	1
14	11688CR	PIN 1.00X6.31D&T	2
15	9320	PIN CAP 0.44X1.75X0.19 SS	6
16	C6353	WASHER 0.38 FLAT GR8	6
17	13573	CAP SCR 0.38-16X1.00 HHGR8	6
18	42516ZP	PIN 1.00X5.13 D&T	1
19	42517ZP	PIN TEAR DROP 1.00X2.19	1
20	5591	WASHER 0.31 SAE FLAT YELLOW GR8	1
21	21170	CAP SCR 0.31-18X1.00 HHGR8	1
23	D0917	WASHER 0.25 FLAT SS	2
24	0479	CAP SCR 0.25-20X0.75 HHGR5	3
25	0521	WASHER 0.25 LOCK	2
26	67869	WINCH 2500DC 24V WARN	1
27	50111	CAP SCR 12MMX45MM HHGR8	4
28	42788	WASHER 0.44 SAE FLAT YELLOW GR8	4
29	51168PC	COVER WEAR PAD EC5000	2
30	0492	CAP SCR 0.38-16X0.75 HHGR5	8
31	0346	WASHER 0.38 USS FLAT	8
32	0523	WASHER 0.38 LOCK	8
33	51169	WEAR PAD 0.50X1.00 RND	4
34	0536	NUT 0.44-14 HHGR5	1
35	C0081	CLAMP 0.50 BLK VINYL	1

RADIO RECEIVER SHOWN AS REFERENCE ONLY

Extension Boom Assembly - PN 50611

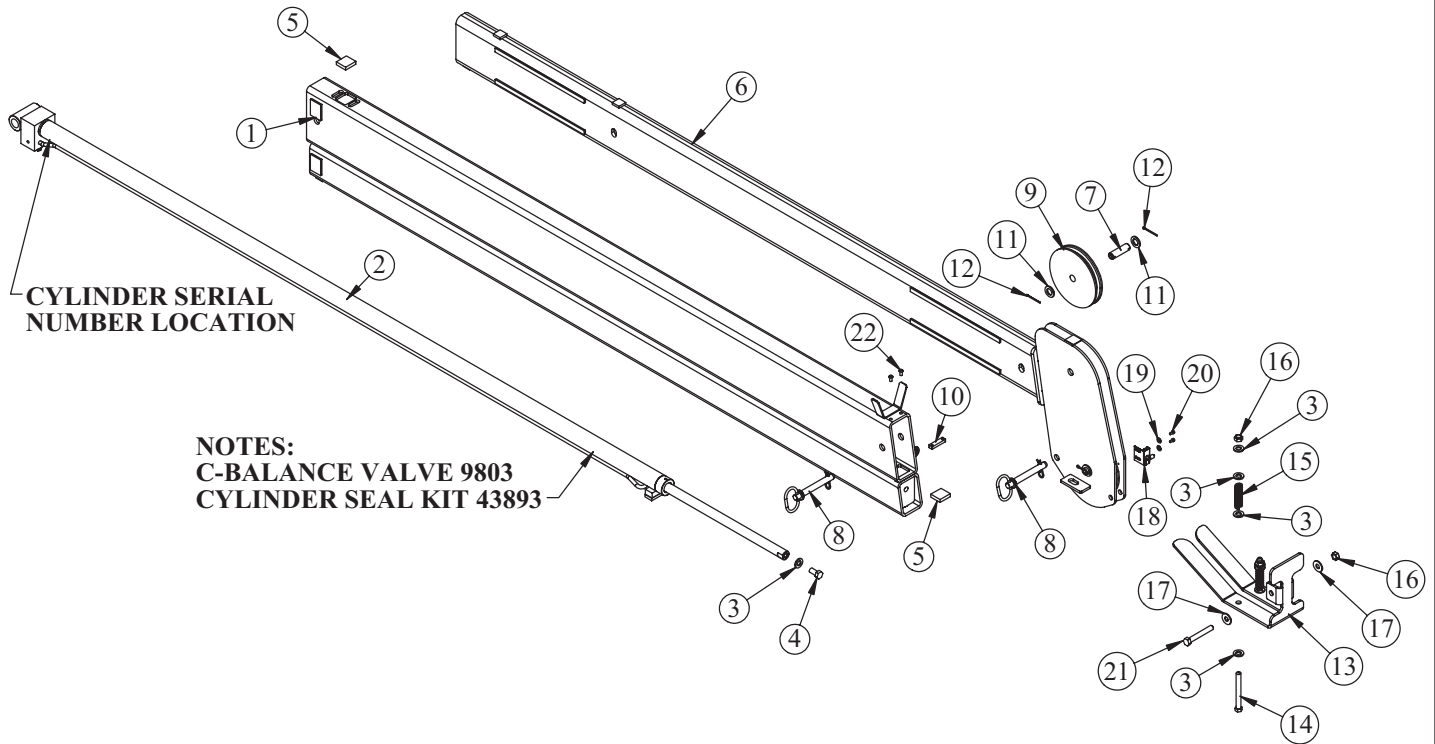

PN 50611

ITEM	PART	DESCRIPTION	QTY.
1	50612	EXT BOOM 1ST EC5000	1
2	50616	CYLINDER 1.50X60.00	1
3	D0790	WASHER 0.50 FLAT GR8	9
4	10172	CAP SCR 0.50-13X1.00 HHGR8 ZY	1
5	42509	WEAR PAD 0.38X1.38X1.50	2
6	50617	EXT BOOM 2ND EC5000	1
7	42524CR	PIN 0.75X2.50 COTTER ZC	2
8	42977	PIN HITCH 0.63X4.00	2
9	50387	SHEAVE EC4000 6.75 DIA .31R/1.00THK	2
10	42978	FLAT BOOM STOP EC3200 PC BLACK	1
11	0423	MACHY WASHER 0.75ID 10GA	4
12	37824	COTTER PIN .125X1.00	4
13	50386	PLATE CRADDLE EC4000 PC BLACK	1
14	0507	CAP SCR 0.50-13X4.50 HHGR5	2
15	27710	SPRING ANTI 2 BLOCK CRADLE A2B	2
16	C6106	NUT 0.50-13 HHGR5 NYLOC	3
17	0352	WASHER 0.50 USS FLAT ZINC	2
18	35105	SWITCH LIMIT E1117-B9111-6C	1
19	D0178	WASHER #10 SAE FLAT ZINC	2
20	43846	SCREW #10-24X0.38 SH SS	2
21	0505	CAP SCR 0.50-13X3.50 HHGR5	1
22	D0561	CAP SCR 0.25-20X0.50 BTNHD SS	2

Gear Bearing Assembly - PN 69735

USE EP2 LITHIUM COMPLEX GREASE, STELLAR PN 78090
ON WORM BEARINGS AND BEARING RACE

GREASE MAIN BEARING RACE THROUGH
REMOVED MOUNTED GREASE ZERK

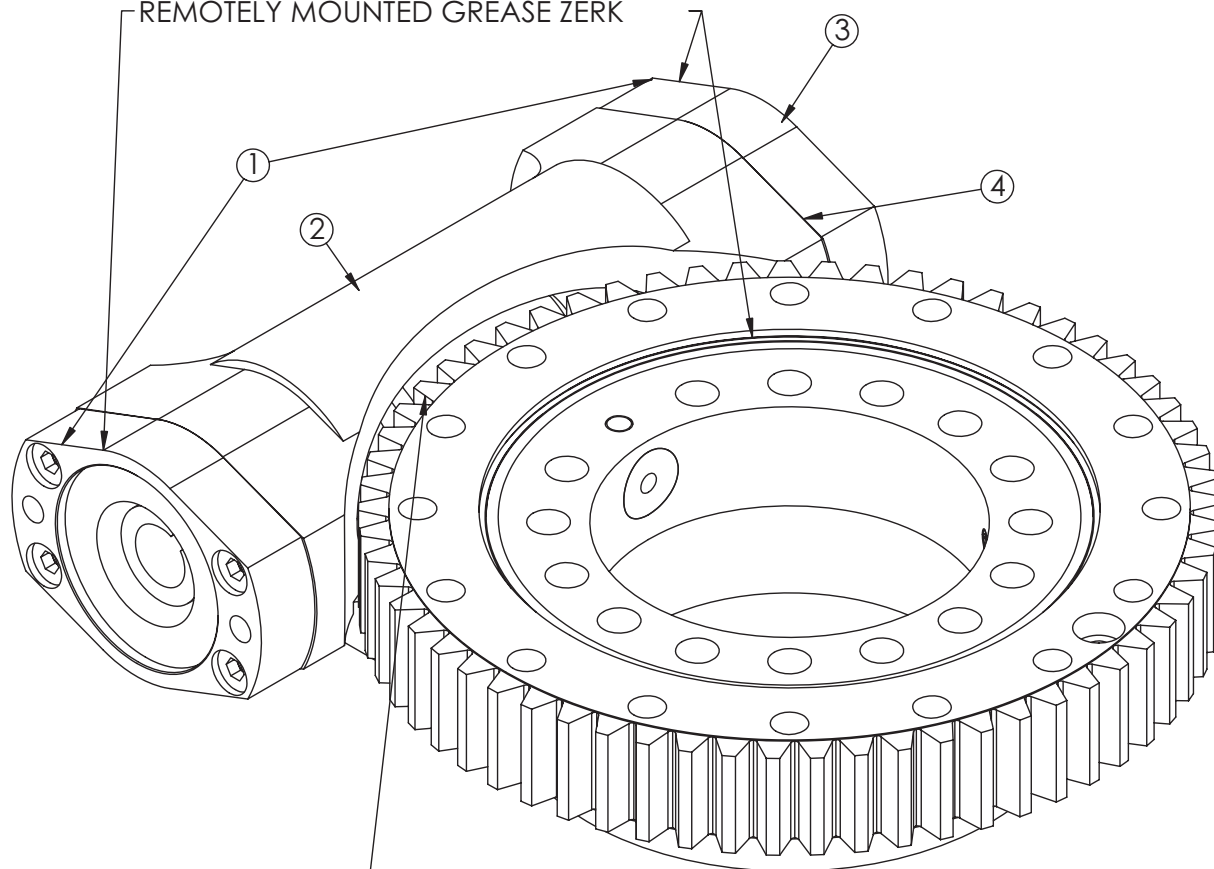

USE MOLY GREASE 936SF HEAVY, STELLAR PN 4460
ON WORM AND BEARING GEAR TEETH

PN 69735

ITEM	PART No.	DESCRIPTION	QTY.
1	67866	BEARING AND SEAL KIT 9IN/14IN/17IN TTB KNMTS AFTER 2006	1
2	77739	WORM EC4000/EC5000 KNMTS	1

Cable & Hook Assembly - PN 50492

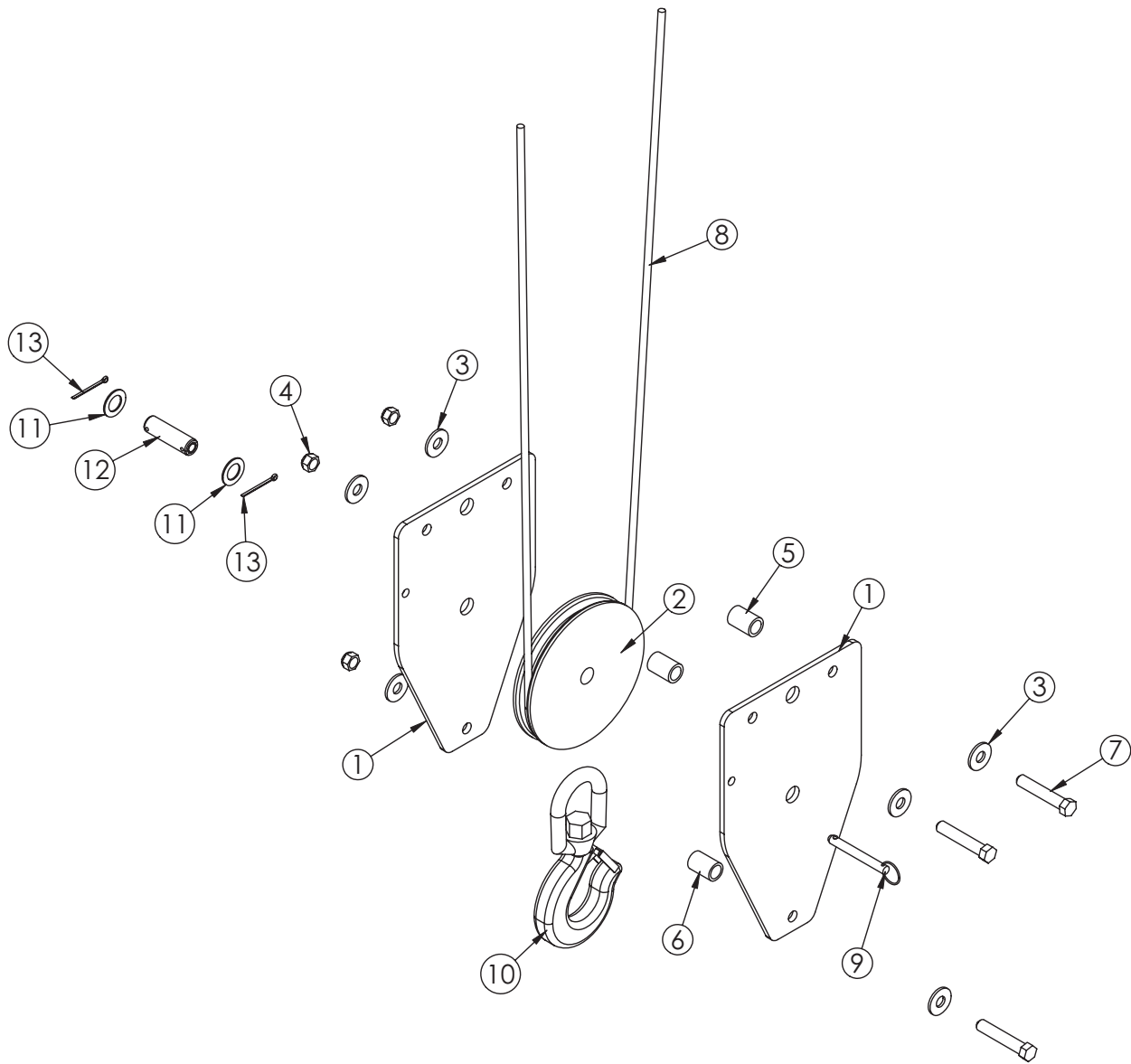

PN 50492

ITEM	PART	DESCRIPTION	QTY.
1	50493PC	PLATE SNATCH BLOCK EC4000	2
2	50387	SHEAVE EC4000 6.75 DIA .31R/1.00THK	1
3	0352	WASHER 0.50 USS FLAT ZINC	6
4	5468	NUT 0.50-13 HHGR8 NYLOC	3
5	27810	SPACER 3315 SNATCH BLOCK UHMW	2
6	16607PC	SPACER 3315 SNATCH BLOCK	1
7	47868	CAP SCR 0.50-13X2.75 HHGR8	3
8	9610	WIRE ROPE 0.31 6X19 IWRC-XIP 90FT	1
9	9263	PIN .38X3.00 QUICK RELEASE	1
10	C6018	HOOK CRANE-3 TON	1
11	0375	MACHY WASHER 0.75ID 14GA	2
12	42524ZP	PIN 0.75X2.50 COTTER	1
13	37824	COTTER PIN .125X1.00	2

Radio Transmitter Assembly - PN 67894

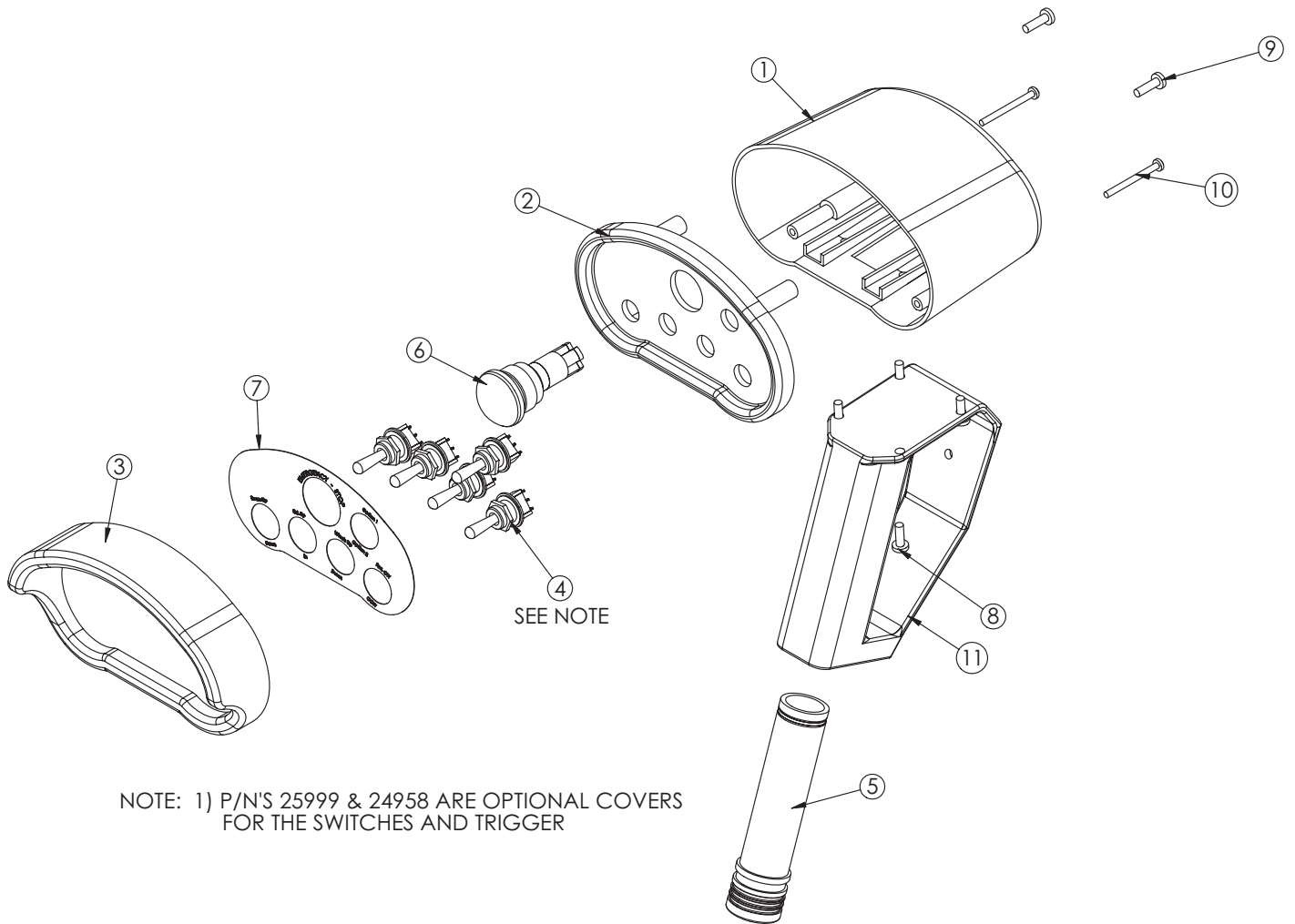

PN 67894

ITEM	PART	DESCRIPTION	QTY.
1	20088	CONTROL HANDLE HOUSING 4 FCTN HET	1
2	51830	CONTROL HANDLE FACE PLT 5 FCTN	1
3	24385	GUARD RADIO SWITCH 4 FCTN	1
4	22600	SWITCH TOGGLE HET RADIO 63019300	5
5	35441	BATTERY TUBE AA HETRONIC RADIO	1
6	16975	SWITCH E STOP ASM HETRONIC RADIO	1
7	51831	DECAL CONTROL HANDLE 5 FCTN	1
8	38475	SCREW 4MMX12MM PHMS PH	4
9	36156	SCREW 4MMX14MM PHMS PH	2
10	29460	SCREW 3MMX35MM PHMS PH	2
11	50932	CONTROL HANDLE GRIP LESS TRIGGER HET H2	1



Subject to Change without Notification.
© 2023 Stellar Industries, Inc.