

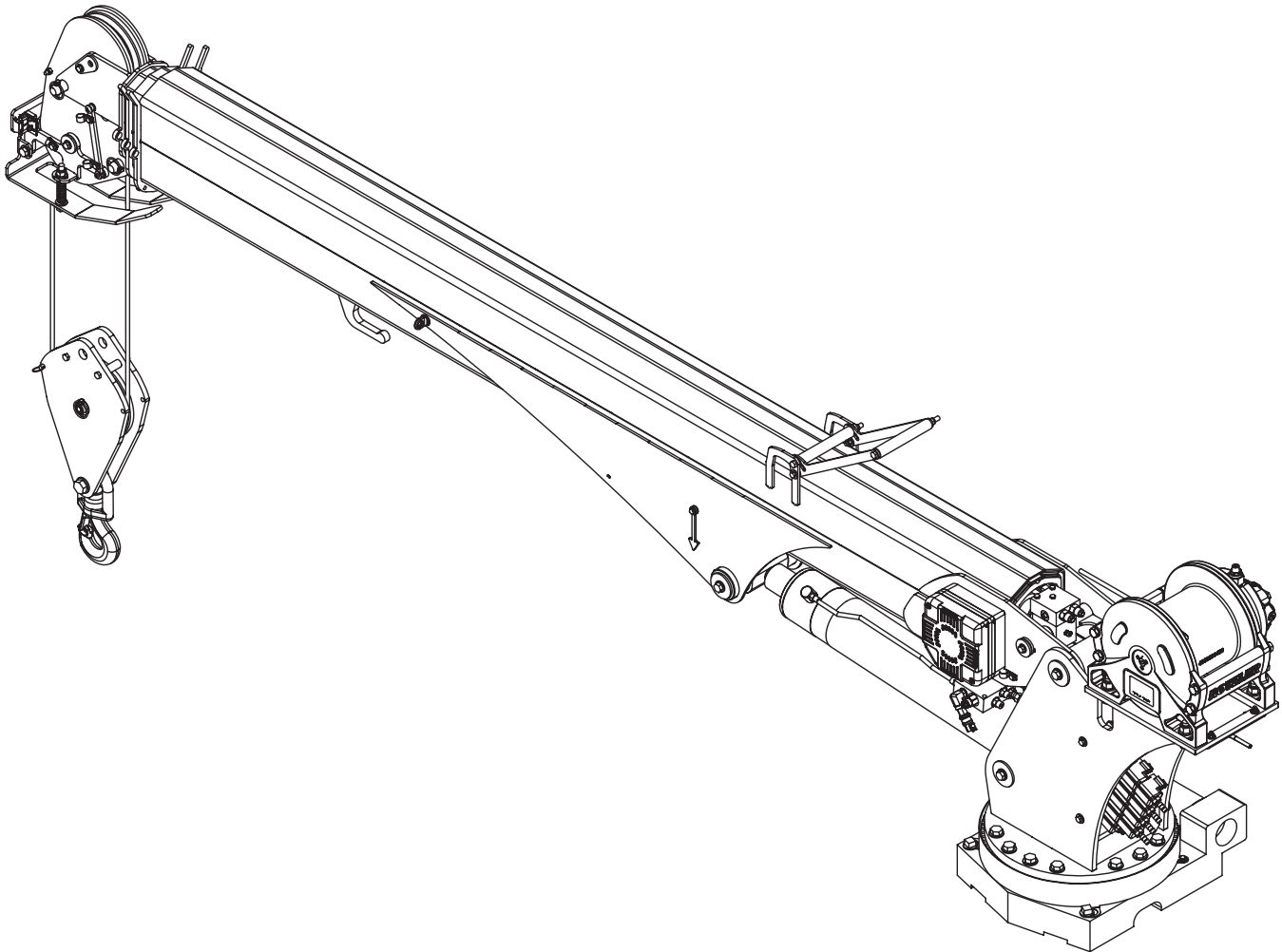

Model 7621 Telescopic Crane Owner's Manual

Installation • Assembly Drawings • Parts



**Notice: A copy of this manual must remain with the equipment at all times.
For a printable download copy, please visit: www.stellarindustries.com**

Stellar Industries, Inc.

190 State Street

PO Box 169

Garner, IA 50438

800-321-3741

Fax: 641-923-2811

www.stellarindustries.com

Subject to Change without Notification.
© 2024 Stellar Industries, Inc.

Rev 2
PN 108539

P65 Warning / Serial Tag Location / Cold Weather

WARNING

Operating, maintaining, and servicing a Stellar product may expose you to chemicals including, but not limited to, engine exhaust, carbon monoxide, phthalates, and lead. These chemicals are known to the State of California to cause cancer and birth defects (or other reproductive harm). To keep your exposure to a minimum, be sure to avoid breathing exhaust and service your Stellar product in a well-ventilated area while wearing gloves or washing your hands frequently. For more information, go to www.P65Warnings.ca.gov/passenger-vehicle.

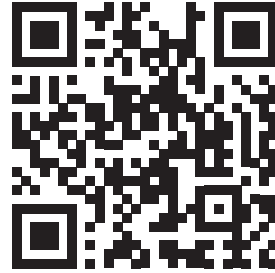

www.p65/warning.ca.gov

NOTICE

Cold Weather Performance

Although clear data on cold weather performance from every steel manufacturer is not available for all types and thicknesses of steel, Stellar Industries is confident that the weldments on our products will operate to 100% of their intended purpose to temperatures down to -40° F / C.

It is recommended if Stellar manufactured equipment needs to be used in temperatures below -40° F / C, the operator should pull the unit into a climate-controlled area and allow the weldments to warm up to and then maintain a temperature above this level.

Serial Tag Location

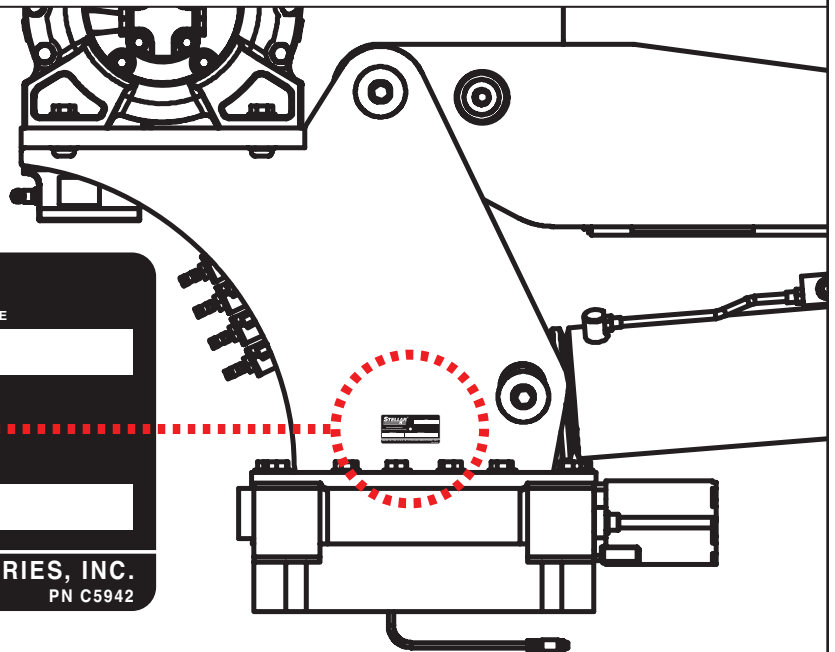
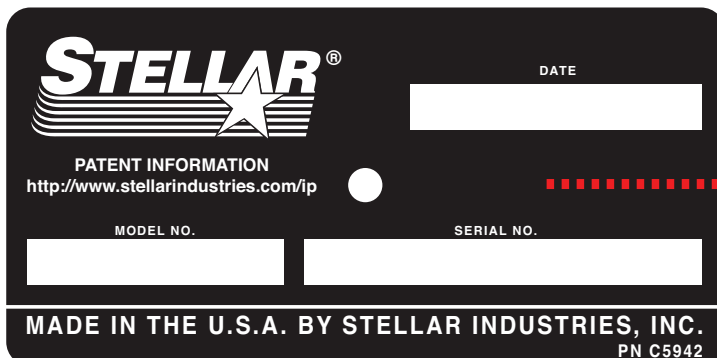

Table of Contents

Introduction	iv
Chapter 1 - Specifications	1
Model 7621 Specifications	2
Capacity Chart - Decal PN 118555	3
Dimensional Drawing 1	4
Dimensional Drawing 2	5
Chapter 2 - Installation.....	7
General Installation	8
Installer Notice	8
Torque Data Chart	9
Installation Overview.....	10
Installation Overview - Continued	11
Control Kit - PN 118530	12
Control Kit - PN 118530 Parts List	13
Electrical Circuit Grounding	14
Valve Bank - PN 125254	16
Valve Bank - PN 125254 Parts List.....	17
Alternate Valve Bank - PN 44530.....	18
Alternate Valve Bank - PN 44530 Parts List.....	19
Hydraulic Kit - PN 107780.....	20
Hydraulic Kit - PN 107780 Parts List.....	21
Hydraulic Installation.....	22
Winch Case Drain Installation	23
Hydraulic System	24
Face Seal/O-Ring Size Chart.....	24
Stability Procedure	25
Crane Load Level Indicator	26
Decal Placement - PN 117189	27
Chapter 3 - Assembly Drawings.....	29
Base Assembly - PN 50364	30
Base Assembly - PN 50364 Parts List	31
Gear Bearing - PN 47869	32
Gear Bearing - PN 47869 Parts List	33
Mast Assembly - PN 131786.....	34
Mast Assembly - PN 131786 Parts List.....	35
Winch - PN 107773.....	36
Winch - PN 107773 Parts List.....	37
Main Boom Assembly - PN 108542	38
Main Boom Assembly - PN 108542 Parts List	39
Extension Boom Assembly - PN 108547	40
Extension Boom Material List - PN 108547 Parts List	41
Extension Boom Material List - PN 108547 Parts List	42
Main Cylinder Assembly - PN 113682.....	44
Main Cylinder Assembly - PN 113682 Parts List.....	45
Extension Cylinder Assembly - PN 108684	46
Extension Cylinder Assembly - PN 108684 Parts List	47
Snatch Block Assembly - PN 56266	48
Snatch Block Assembly - PN 56266 Parts List	49
Wireless Remote Replacement Parts	50
Wireless Remote Replacement Parts List	51

Introduction

A copy of this manual is provided with every crane and can be found in the hard plastic manual case that is installed on the chassis. A copy of this manual shall remain with the crane at all times.

Throughout the manual, three signal words will be used to bring attention to important items:

NOTICE

A *NOTICE* signal word indicates a practice not related to physical injury.

WARNING

A *WARNING* signal word indicates a hazardous situation which, if not avoided, could result in death or serious injury.

DANGER

A *DANGER* signal word indicates a hazardous situation which, if not avoided, will result in death or serious injury.

Information contained within this manual does not cover operation, maintenance, or troubleshooting. Please refer to the General Heavy Duty Crane Manual for details on these items.

This manual is not binding. Stellar Industries, Inc. reserves the right to change, at any time, any or all of the items, components, and parts deemed necessary for product improvement or commercial/production purposes. This right is kept with no requirement or obligation for immediate mandatory updating of this manual.

If more information is required or technical assistance is needed, or if you feel that any part of this manual is unclear or incorrect, please contact the Stellar Customer Service Department by phone at 800-321-3741 or email at service@stellarindustries.com.

**For Technical Questions, Information, Parts, or Warranty, Call Toll-Free at
800-321-3741**

Hours: Monday - Friday, 8:00 a.m. - 5:00 p.m. CST

Or email at the following addresses:

Technical Questions, and Information

service@stellarindustries.com

Order Parts

parts@stellarindustries.com

Warranty Information

warranty@stellarindustries.com

Chapter 1 - Specifications

Chapter Contents

Model 7621 Specifications	2
Capacity Chart - Decal PN 118555	3
Dimensional Drawing 1	4
Dimensional Drawing 2	5

Model 7621 Specifications

SPECIFICATIONS	
CRANE RATING*	44,840 FT-LBS (6.2 TM)
STANDARD BOOM LENGTH	11' 0" (3.35 m) FROM CL OF CRANE
BOOM EXTENSION:	1ST STAGE: HYDRAULIC 60" (152.4 cm)
	2ND STAGE: HYDRAULIC 60" (152.4 cm)
MAXIMUM HORIZONTAL REACH:	21' 0" (6.40 m) FROM CL OF CRANE
MAXIMUM VERTICAL LIFT	22' 11" (7.0 m) FROM CRANE BASE
STOWED HEIGHT (CRANE ONLY)	38.6" (98 cm)
REQUIRED MOUNTING SPACE	20" X 21" (50.8 cm x 53.3 cm)
APPROXIMATE CRANE WEIGHT	7621 HSS STANDARD: 1,560 LBS (708 kg)
CONTROLS	RADIO CONTROL STANDARD FOR ALL FUNCTIONS.
WIRE ROPE	3/8" (0.95 cm) X31 IWRC-DGXIP X 100' (30.48 m)
BOOM ELEVATION	-10° TO +80°
WINCH SPECIFICATIONS	
LINE PULL SPEED:	SPEED: 60 FT/MIN (18.29 m/min)
MAX. SINGLE PART LINE:	3,750 LBS (1,700 kg)
MAX. DOUBLE PART LINE	7,500 LBS (3,400 kg)
ROTATION (WORM GEAR):	400° POWER
LIFTING CAPACITY**	7,500 LBS @ 5'10" (3,400 kg @ 1.78 m)
	2,185 LBS @ 20'6" (991 kg @ 6.24 m)
POWER SUPPLY	PTO & PUMP: 8 GPM @ 3,000 PSI (30.3 Lpm @ 207 Bar)

NOTES:

*CRANE RATING IN BOOST MODE. NORMAL CRANE RATING IS 38,000 FT-LBS (5.25 TM).

**MAXIMUM CAPACITIES IN BOOST MODE.

Capacity Chart - Decal PN 118555

IMPORTANT

Weight of load handling devices are part of the load lifted and must be deducted from the capacity.

Maximum single-part line capacity is 3750 lbs (1700 kg). For greater loads, use two-part line.

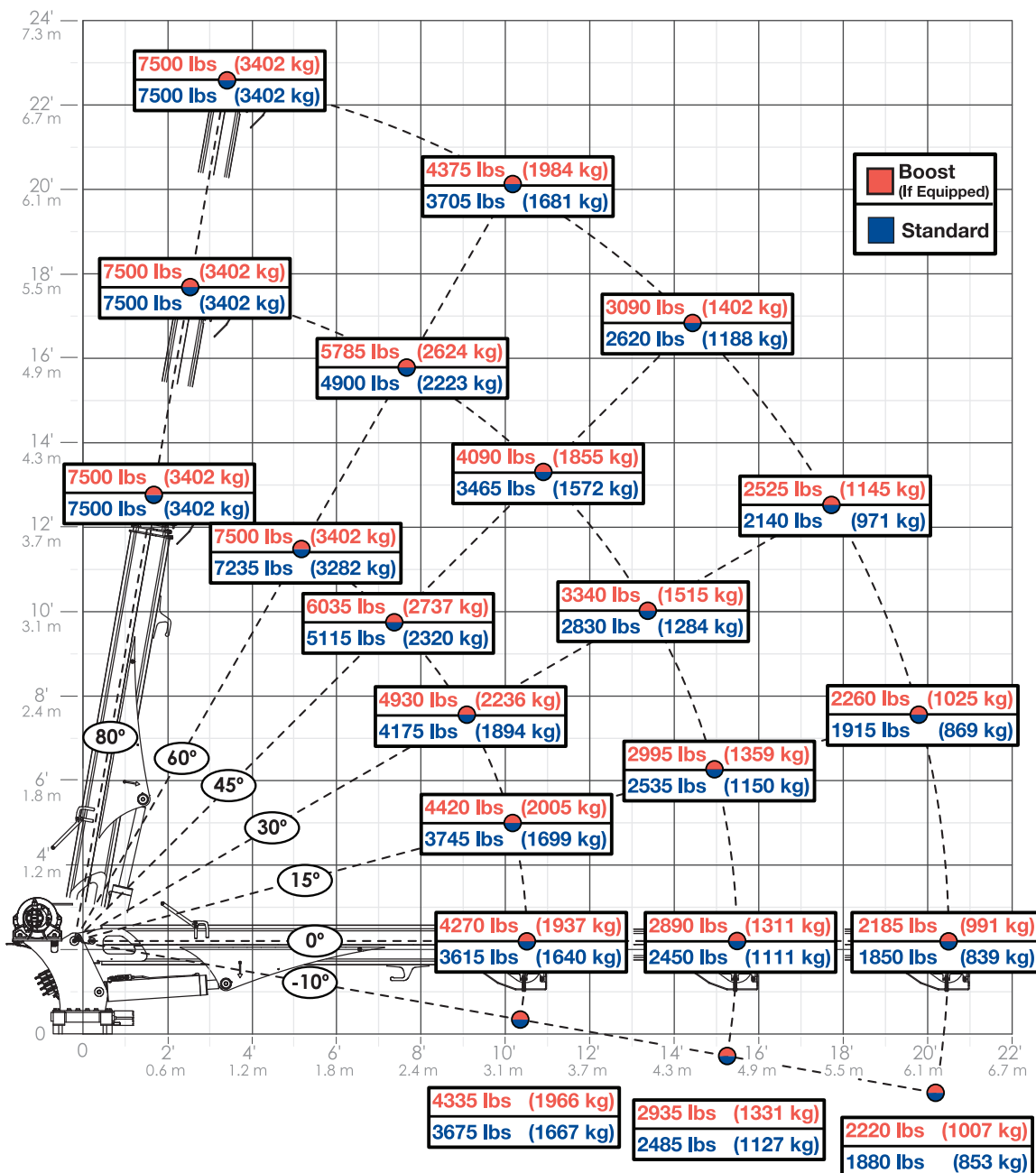

PN 118555v2

Dimensional Drawing 1

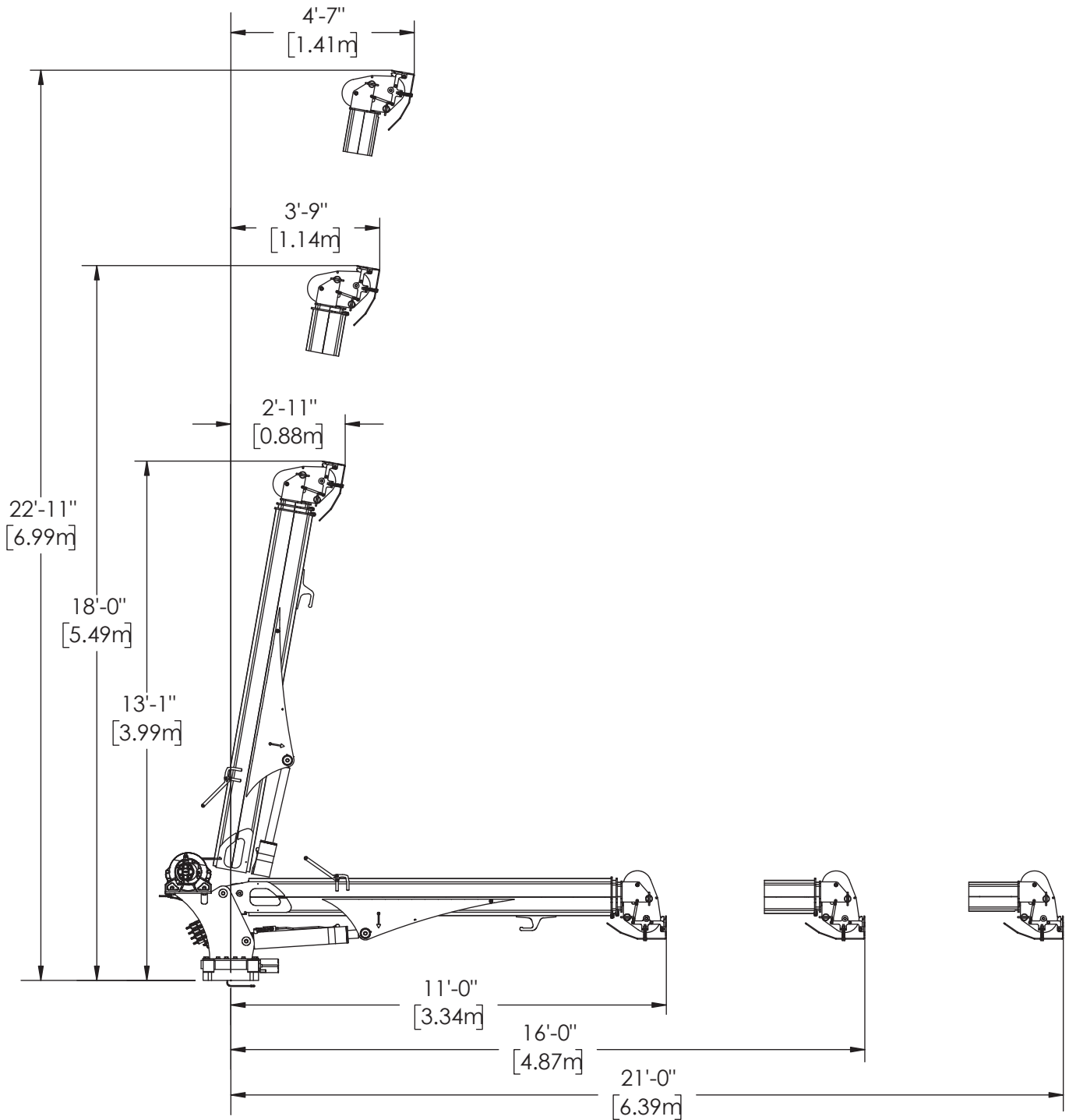

Dimensional Drawing 2

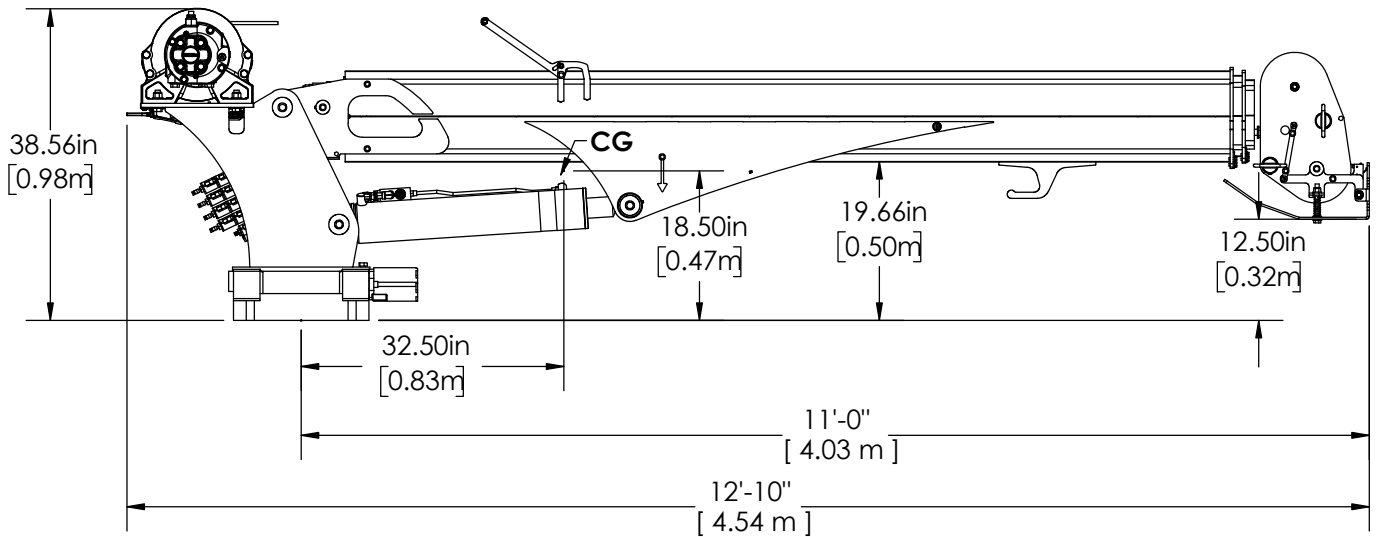
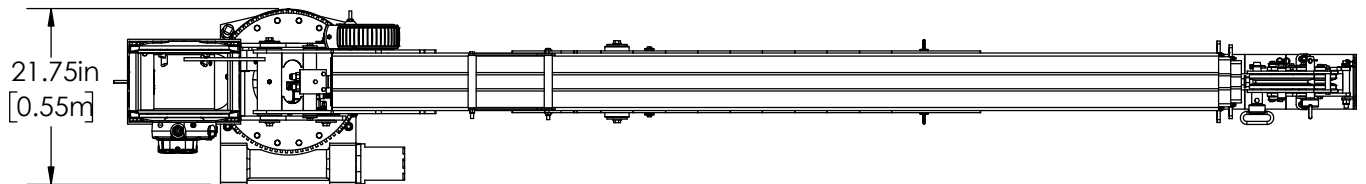
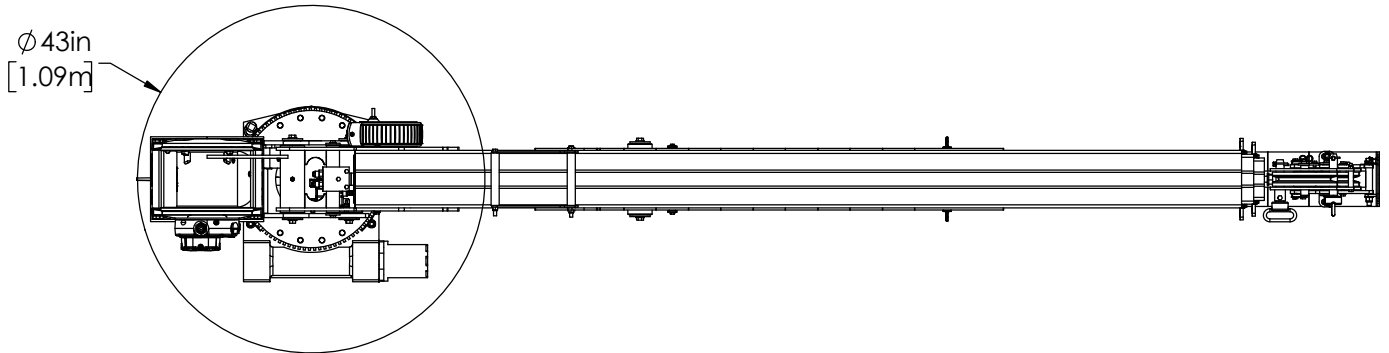

This page left intentionally blank.

Chapter 2 - Installation

Chapter Contents

General Installation	8
Installer Notice	8
Torque Data Chart.....	9
Installation Overview	10
Installation Overview - Continued	11
Control Kit - PN 118530	12
Control Kit - PN 118530 Parts List	13
Electrical Circuit Grounding.....	14
Valve Bank - PN 125254	16
Valve Bank - PN 125254 Parts List.....	17
Alternate Valve Bank - PN 44530.....	18
Alternate Valve Bank - PN 44530 Parts List.....	19
Hydraulic Kit - PN 107780.....	20
Hydraulic Kit - PN 107780 Parts List.....	21
Hydraulic Installation	22
Winch Case Drain Installation	23
Hydraulic System	24
Face Seal/O-Ring Size Chart.....	24
Stability Procedure	25
Crane Load Level Indicator	26
Decal Placement - PN 117189.....	27

General Installation

This chapter is designed to serve as a general guide for the installation of a Stellar 7621 Crane on a Stellar Service Body. Each installation is considered unique so certain portions of this chapter may or may not apply to your direct application. If a question should arise during the installation process, please contact Stellar Customer Service at (800) 321 3741.

This crane is designed for use with a Stellar Service Body installed on a vehicle that meets the minimum chassis requirements of the crane. It is the installer's responsibility to assure that the crane is mounted on a platform that will support the maximum crane rating of this crane.

NOTICE

When installing welder units to the service bodies, it is highly recommended that a surge protector is installed on the chassis batteries to protect the crane radio receiver, wiring and other electronic devices from an unexpected electrical spike or surge. Failure to do so could result in extensive damage to the service body and crane electrical circuit.

⚠ WARNING

Do not install this crane on a body not capable of handling the loads imposed on it. Failure to do so may result in serious injury or death.

Installer Notice

According to Federal Law (49 cfr part 571), each final-stage manufacturer shall complete the vehicle in such a manner that it conforms to the standards in effect on the date of manufacture of the incomplete vehicle, the date of final completion, or a date between those two dates. This requirement shall, however, be superseded by any conflicting provisions of a standard that applies by its terms to vehicles manufactured in two or more stages.

Therefore, the installer of Stellar® Cranes and Bodies is considered one of the manufacturers of the vehicle. As such a manufacturer, the installer is responsible for compliance with all applicable federal and state regulations. They are required to certify that the vehicle is in compliance with the Federal Motor Vehicle Safety Standards and other regulations issued under the National Traffic and Motor Vehicle Safety Act.

Please reference the Code of Federal Regulations, title 49 - Transportation, Volume 5 (400-999), for further information, or visit <http://www.gpoaccess.gov/nara/index.html> for the full text of Code of Federal Regulations.

Torque Data Chart

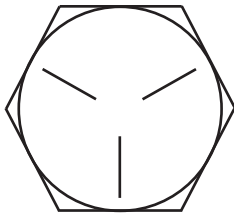
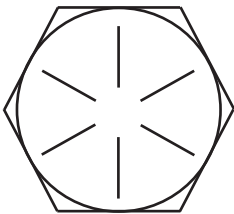
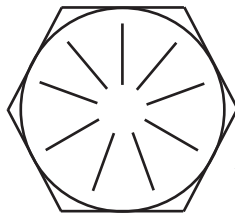
		GRADE 5		GRADE 8		GRADE 9
						
SIZE (DIA-TPI)	BOLT DIA (INCHES)	PLAIN (FT-LB)	PLATED (FT-LB)	PLAIN (FT-LB)	PLATED (FT-LB)	PLATED (FT-LB)
5/16-18	0.3125	17	13	25	18	22
3/8-16	0.3750	31	23	44	33	39
7/16-14	0.4375	49	37	70	52	63
1/2-13	0.5000	75	57	105	80	96
9/16-12	0.5625	110	82	155	115	139
5/8-11	0.6250	150	115	220	160	192
3/4-10	0.7500	265	200	375	280	340
7/8-9	0.8750	395	295	605	455	549
1-8	1.000	590	445	910	680	823
1 1/8-7	1.1250	795	595	1290	965	1167
1 1/4-7	1.2500	1120	840	1815	1360	1646
1 3/8-6	1.3750	1470	1100	2380	1780	2158
1 1/2-6	1.500	1950	1460	3160	2370	2865

NOTE:

When using the torque data in the chart, the following rules should be observed:

- Bolt manufacturer's particular specifications should be consulted when provided.
- Flat washers of equal strength must be used.
- All torque measurements are given in foot-pounds. To convert to inch-pounds, multiply by 12.
- Torque values specified are for bolts with residual oils or no special lubricants applied.
- Torque values for socket-head capscrews are the same as for grade 8 capscrews.
- Do not use these values if a different torque value or tightening procedure is given for a specific application. Torque values listed are for general use only. Check tightness of fasteners periodically.
- Shear bolts are designed to fail under predetermined loads. Always replace shear bolts with identical grade.
- Fasteners should be replaced with the same or higher grade. If higher grade fasteners are used, these should only be tightened to the strength of the original.
- Tighten plastic insert or crimped steel-type lock nuts to approximately 110 percent of the dry torque values shown in the chart below, applied to the nut, not to the bolt head. Tighten toothed or serrated-type lock nuts to the full torque value. *Note: "Lubricated" means coated with a lubricant such as engine oil, or fasteners with phosphate and oil coatings. "Dry" means plain or zinc plated without lubrication. Tighten lubricated bolts to approximately 80% of dry bolts.*

Installation Overview

1. Determine that the mounting location for the 7621 is at least 18" x 20" (45.7 x 50.8 cm).
2. Use the detail below to drill 1.06" diameter holes into the mounting plate. Run tap on the threads of the base to be sure they are clean.
3. Use a crane or lifting device capable of lifting the weight of the Stellar® Crane. The 7621 HSS weighs approximately 1,560 lbs (708 kg). **Note: Cranes are shipped with rotation positioned at 200 degrees of 400 degree system.** This will allow for easy installation of the crane and permanent connection of all hydraulic and electrical components prior to repositioning into the crane saddle.
4. Connect straps or chain from the lifting device to the lifting rings on the 7621.
5. Use four (4) 1" x 3" #8 bolts and four (4) #8 flat washers.
6. Install a washer on each bolt.
7. Apply Loctite Thread locker #277 to the bolts.
8. Using the lifting device, lower the 7621 just above the crane compartment and start the bolts. Have someone assist in leveling the crane. **Note: the rotation motor should be to the door side of crane compartment and the boom should be extended back over the rear bumper.**
9. Secure the crane using the mounting hardware provided. **Note: longer or shorter cap screws may be required – recommended thread engagement into crane base is 1.75" – use grade 8, zinc plated cap screws only.**
10. Torque the cap screws to 680 ft-lbs.
11. Remove supporting crane.
12. Hook-up hydraulics and electrical.

Installation Overview - Continued

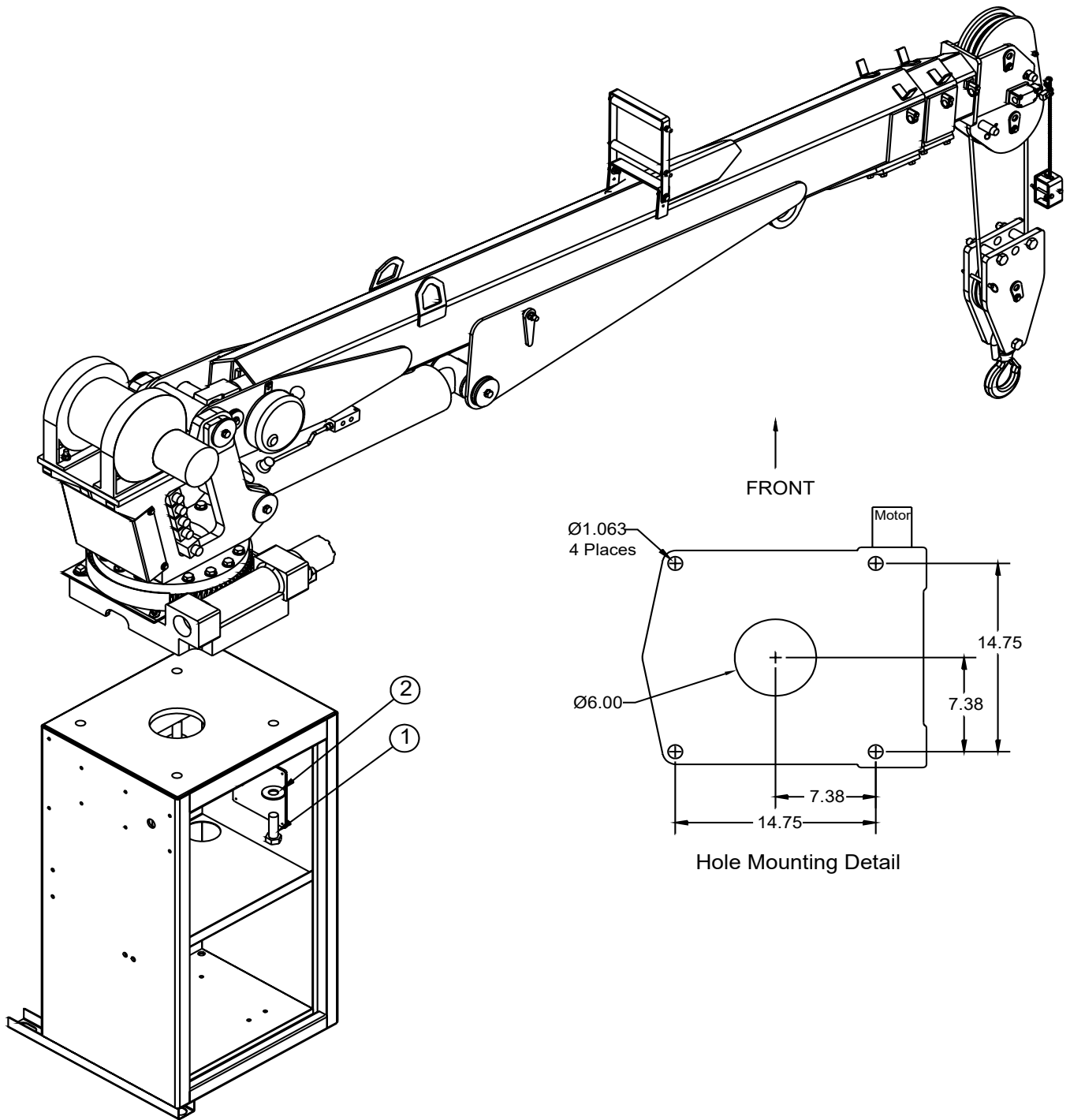

ITEM	PART	DESCRIPTION	QTY
1	5199	CAP SCR 1.00-8X3.00 HHGR8	4
2	6538	WASHER 1.00 SAE FLAT YELLOW GR8	4

Control Kit - PN 118530

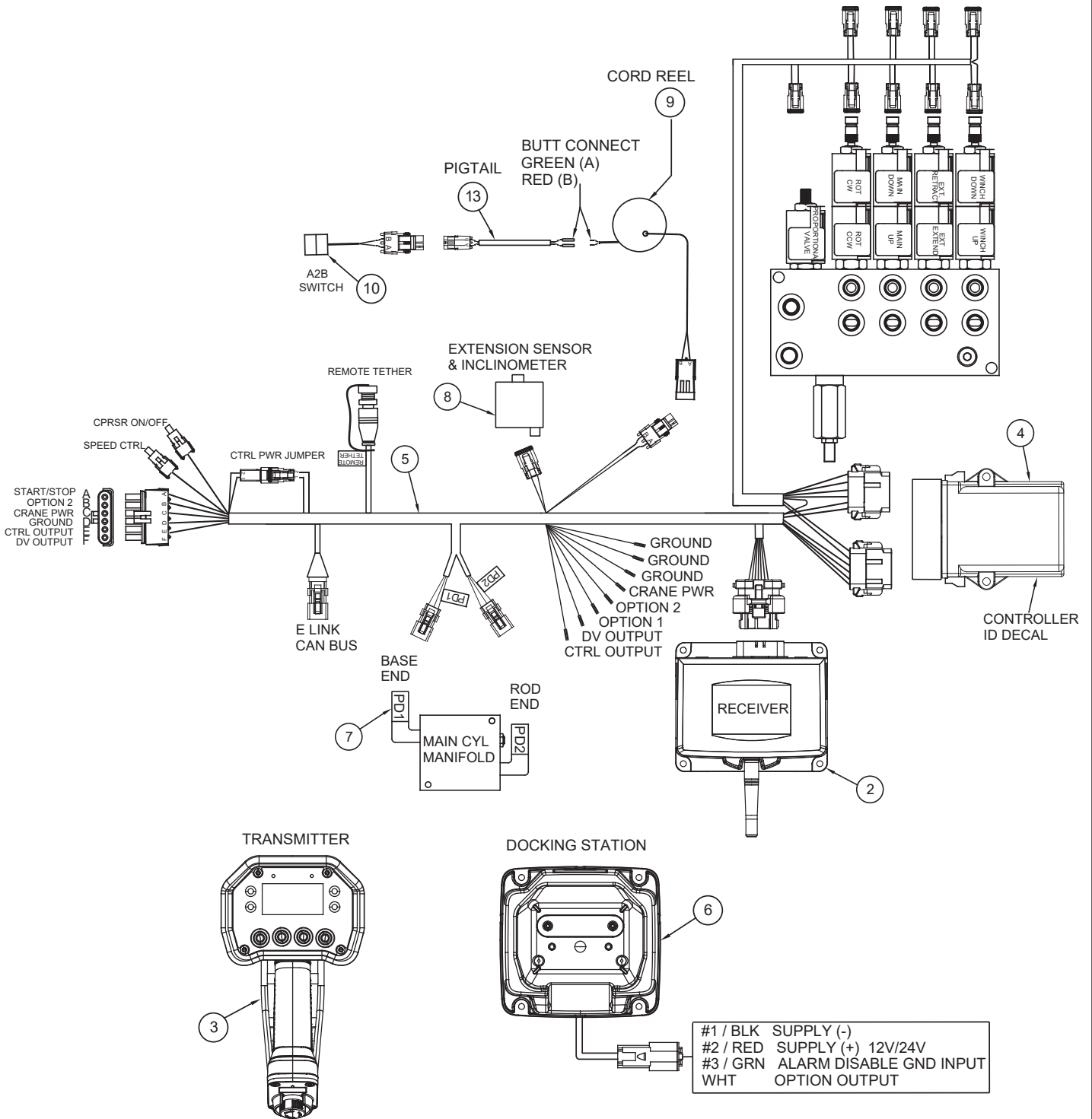

NOTICE

Any modification to the crane control system (electrical and/or hydraulic) must be approved by Stellar Industries, Inc.

Control Kit - PN 118530 Parts List

PN 118530			
ITEM	PART	DESCRIPTION	QTY
01	113550	RADIO CTRL ASM 4 FCTN CDTPRO G6RC PG	1
02	113569	RECEIVER CDTPRO G6RC 2.4GHZ 14P	1
03	113568	TRANSMITTER 4 FCTN MECH CDTPRO G6RC PG	1
04	113571	CTRL MODULE MECH CRANE CDTPRO G6	REF
05	113580	WIRE HRNS MECH CRANE CDTPRO G6 451	REF
06	113551	DOCKING STATION RADIO TRANS CDTPRO	REF
07	108268	TRANSDUCER PRESSURE 0-5000PSI #4 SAE DT	2REF
08	110460	ENCODER BOOM VECTOR 6M CANOPEN	1
09	123760	CORD REEL 29FT 4 WIRE SEALED	1
10	35105	SWITCH LIMIT (NO) ROLLER LVR LT BRKT E1161	1
11	89152	TETHER CABLE 10M M-F M12 SCANRECO	REF
12	119851	TAG QUICK START CDTPRO TX	REF
13	124587	PIGTAIL ASM 14IN 2P WP SHRD	1
REV. A			

Electrical Circuit Grounding

When installing the crane, always locate a good source for grounding the circuit. A majority of electrical failures are due to poor grounding. Poor grounding can cause intermittent operation of the equipment, electrical component failures and cause the equipment to not operate at all.

Chassis manufacturers usually will have a ground strap which ties into the truck frame from the battery, but it is always a good idea to check each individual model to verify where the ground is located. Never use the mechanic body as a ground source. Make sure the electrical grounds are routed to either the chassis frame rail or the chassis's main grounding source.

Stellar provides a stud (PN 40992) for grounding the crane to the chassis frame rail:



Inside Frame Rail



Outside Frame Rail

⚠ WARNING

Drill the hole to the frame rail in accordance with the chassis body builder's guide.

- **Hole size: 21/64"**
- The hole location should allow for the shortest length of ground wire while keeping enough slack for flexibility.
- Be sure to grind the frame rail around the hole to ensure a proper ground connection.
- Frame rail thickness may require additional flat washers (as shown).
- Use an electrical coating on hardware to prevent corrosion.

This page left intentionally blank.

Valve Bank - PN 125254

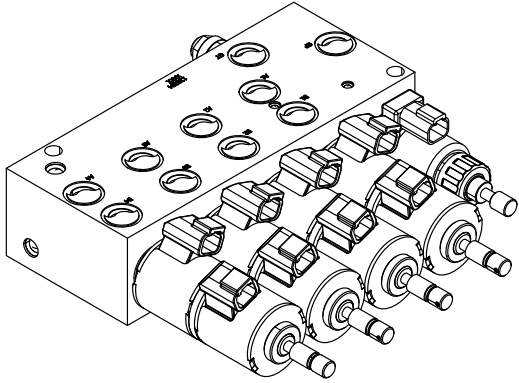

HYDRAULIC SCHEMATIC

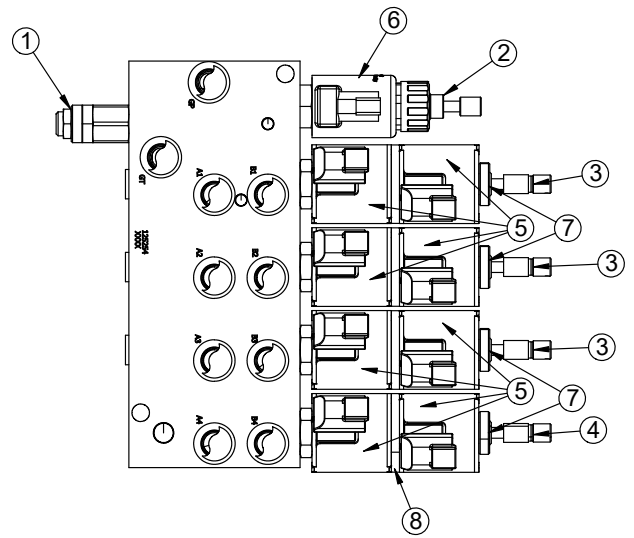
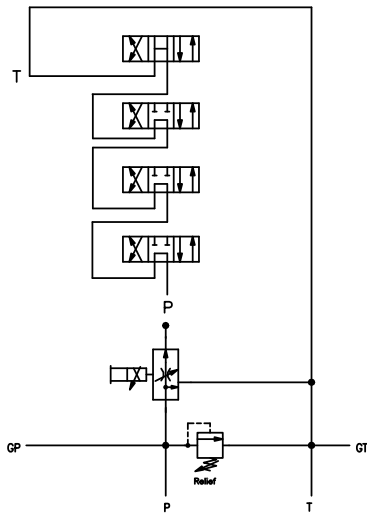

Valve Bank - PN 125254 Parts List

PN 125254				
ITEM	PART	DESCRIPTION	QTY	TORQUE
1	125946	VALVE RELIEF 125254	1	37 FT-LB
	126271	SEAL KIT 125946		
2	135852	VALVE FLW CTRL PRP 0-4 GPM DEL	1	20-22 FT-LB
	126270	SEAL KIT 125255		
3	125256	VALVE SOLND 3 POS 4 WAY 8GPM TANDEM DEL	3	25 FT-LB
4	125257	VALVE SOLND 3 POS 4 WAY 8GPM OPEN DEL	1	25 FT-LB
	126269	SEAL KIT 125256/125257		
5	125947	COIL 12VDC DEUTSCH DEL	8	3 FT-LB
6	125948	COIL 12VDC DEUTSCH PROP DEL	1	3 FT-LB
7	134698	NUT COIL RETAINING DELTROL SIZE 10	4	3 FT-LB
8	139595	SPACER COIL DEL	4	
REV. INITIAL RELEASE				

Alternate Valve Bank - PN 44530

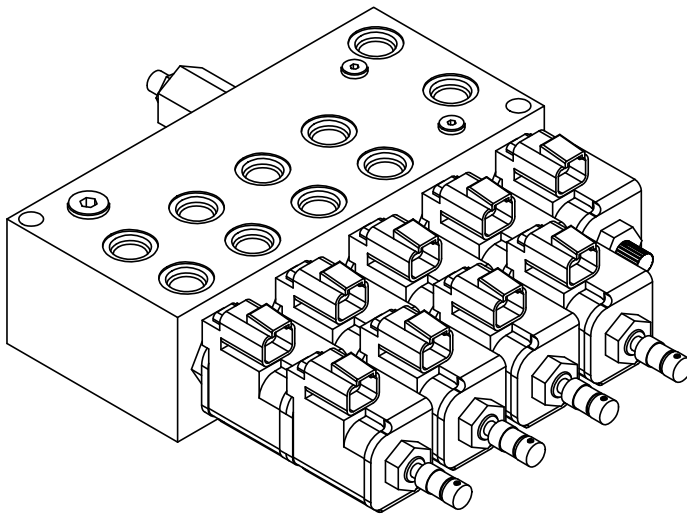
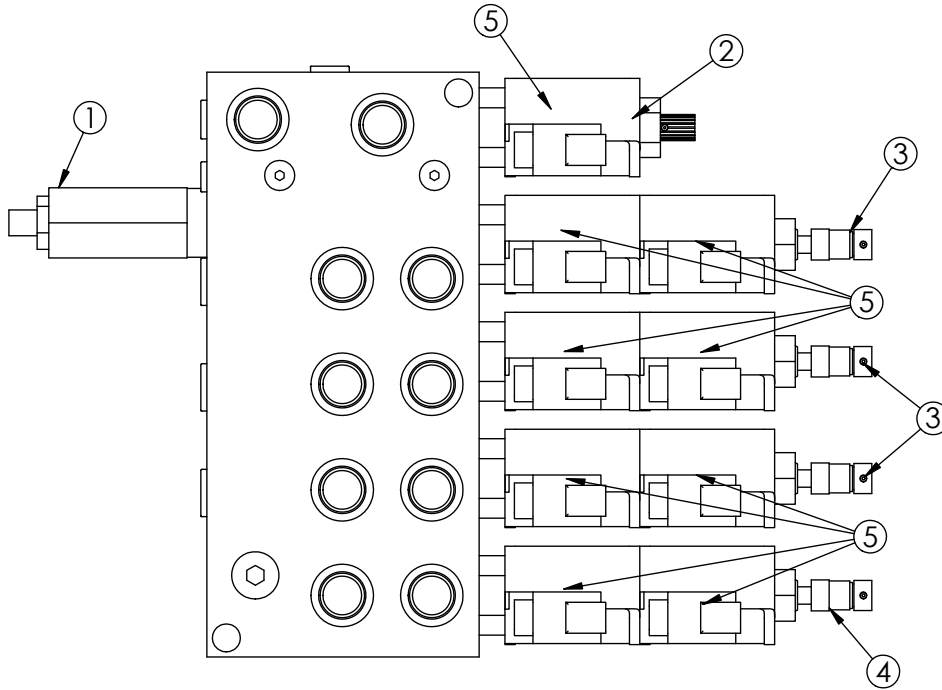

HYDRAULIC SCHEMATIC

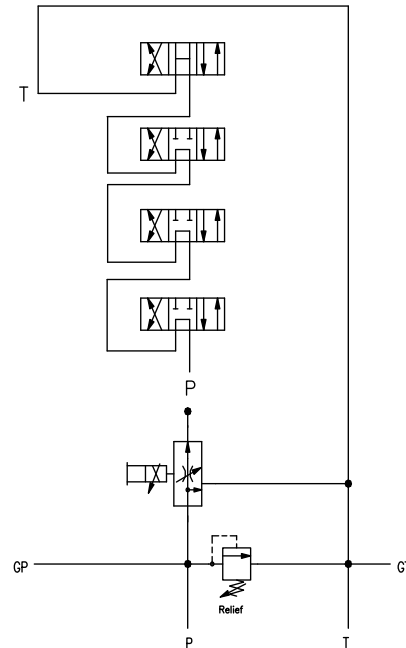

Alternate Valve Bank - PN 44530 Parts List

PN 44530				
ITEM	PART	DESCRIPTION	QTY	TORQUE
1	25367	RELIEF VALVE 24685/2469025369SEAL	1	37 FT-LB
	25368	SEAL KIT 253673253713VALVE		
2	24960	VALVE FLW CTRL PRP/JP04C3150N 0-8	1	20-22 FT-LB
	25369	SEAL KIT 24960 / 25381		
3	25371	VALVE SOLND 3 POS 4 WAY TAND G04571	3	25 FT-LB
4	25372	VALVE SOLND 3 POS 4 WAY OPEN G04571	1	25 FT-LB
	25373	SEAL KIT 25371 / 25372		
5	44532	COIL 12VDC DUETSCH CAP012H	9	3 FT-LB
REV. INITIAL RELEASE				

Hydraulic Kit - PN 107780

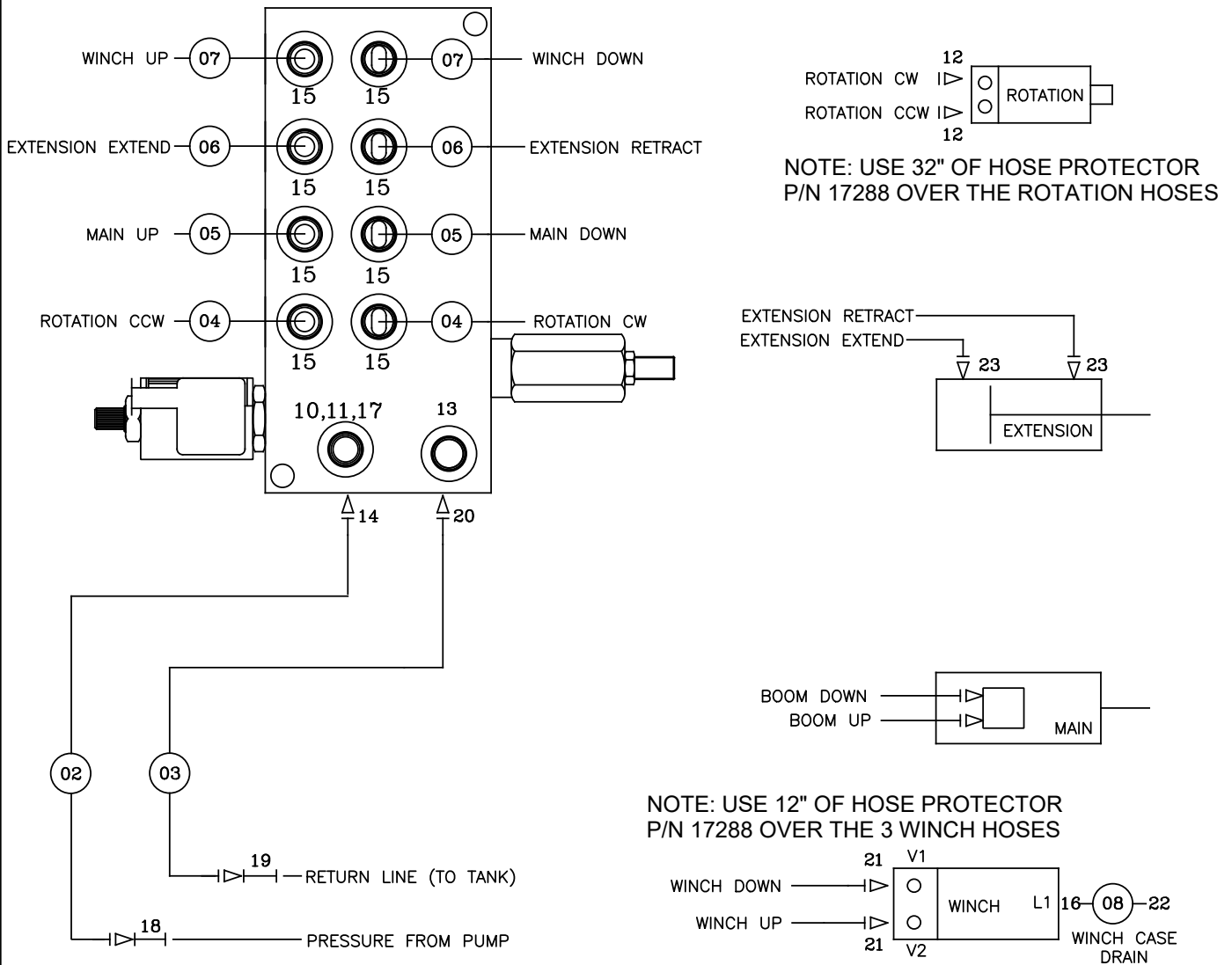

WARNING



HYDRAULIC FLUID HAZARDS

- High pressure fluid leak will pierce skin.
- Release pressure before working on system.

STAND CLEAR OF POTENTIAL HIGH PRESSURE HYDRAULIC FLUID LEAKS

- Wear sturdy gloves and goggles. Detect leaks with wood or cardboard. NEVER use fingers.
- Fluid injected in skin will injure or kill and must be surgically removed by trained doctor immediately or gangrene will result.

BURN HAZARD

- Oil temperatures may exceed 120°F (35°C).
- Do not touch hydraulic system.
- Hot surface can burn.

CHECK HYDRAULIC HOSES, TUBES, AND PIPES DAILY.

Hydraulic Kit - PN 107780 Parts List

PN 107780

ITEM	PART	DESCRIPTION	QTY
01	107781	HOSE KIT 76 HSS	1
02	45439	HOSE 0.38(3000PSI)-6FFSS SHORT-6FFSS 45-9CL	1REF
03	45438	HOSE 0.50(200PSI)-8FFSS SHORT-8FFSS 45-8CL	1REF
04	71903	HOSE 0.38(3000PSI)-6FFSS SHORT-6FFSS 90 MEDIUM-39CL	2REF
05	13028	HOSE 0.38(3000PSI)-6FFSS SHORT-6FFSS 45-17CL	2REF
06	59137	HOSE 0.38(3000PSI)-6FFSS SHORT-6FFSS 45-19CL	2REF
07	104129	HOSE 0.38(3000PSI)-8FFSS SHORT-6FFSS 45-17CL	2REF
08	104128	HOSE 0.25(3000PSI BLUE)-4FFSS SHORT-4FFSS SHORT-34CL	1REF
09	17288	HOSE PROTECTOR 1.00 AS-B-27 WIDTH 2.81	44"
10	15111	FTG 6-4 MORB-FORB STRAIGHT REDUCER	1
11	3861	FTG 6-6 MAORB-FORB 90	1
12	D1302	FTG 6-10 MFS-MAORB 90	2
13	C4961	FTG 6 MORB PLUG HOLLOW HEX	1
14	D1193	FTG 6-6 MFS-MAORB 45	1
15	0279	FTG 6-6 MFS-MORB STRAIGHT	8
16	20421	FTG 4-4 MFS-MBSPP W/BS 90	1
17	39780	GAUGE OIL LF 2.5 0-6000 CBM SAE	1
18	12171	FTG 6-6 MFS-MFS SWIVEL STRAIGHT	1
19	12172	FTG 8-8 MFS-MFS SWIVEL STRAIGHT	1
20	C1175	FTG 8-8 MFS-MAORB 45	1
21	57735	FTG 8-8 MFS-MBSPP W/BS STRAIGHT	2
22	32302	FTG 4-4 MFS-MFS SWIVEL STRAIGHT	1
23	C0338	FTG 6-6 MFS-MAORB 90	2

REV. B

Hydraulic Installation

WARNING

Follow the instructions presented on this page. Failure to follow these instructions may result in death or serious injury.

1. After mounting, locate the pressure and return lines. Note: Pressure line is 3/8" hose; Winch Case Drain Line is 1/4" hose; Return line is 1/2" hose. Hoses are terminated using swivel fittings.
2. Install hydraulic lines per diagram below. See next page for Case Drain Installation. Note: Stabilizer valve supplies oil to crane using the Power Beyond feature.
3. Install hydraulic reservoir with return filter. Attach pump pressure line to valve, return link to tank.
4. Fill system with hydraulic oil (See Stellar® Lubrication Recommendations for fluid details).

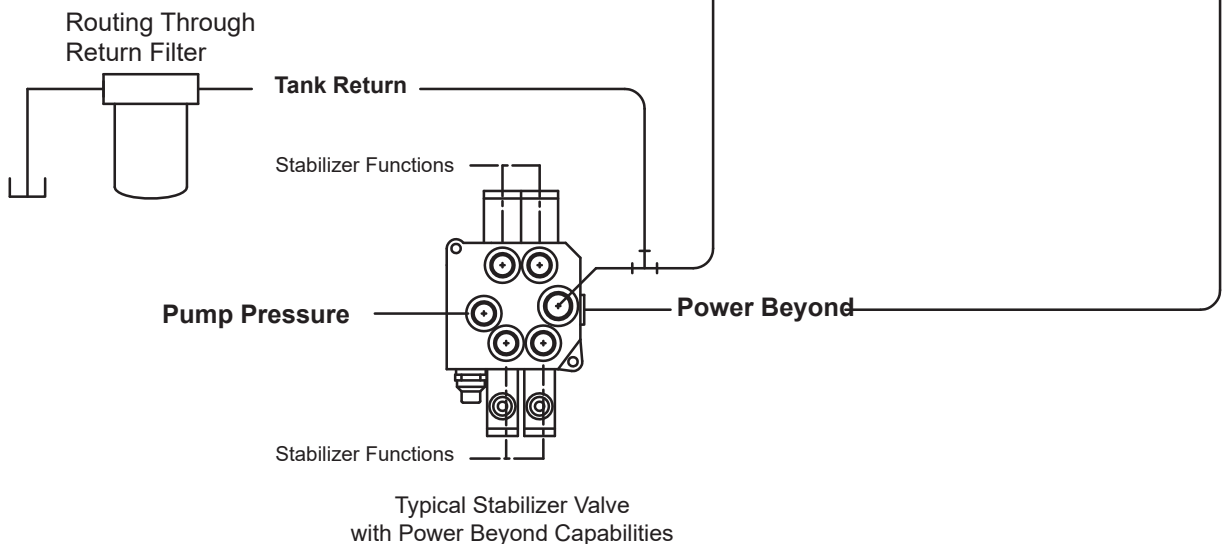
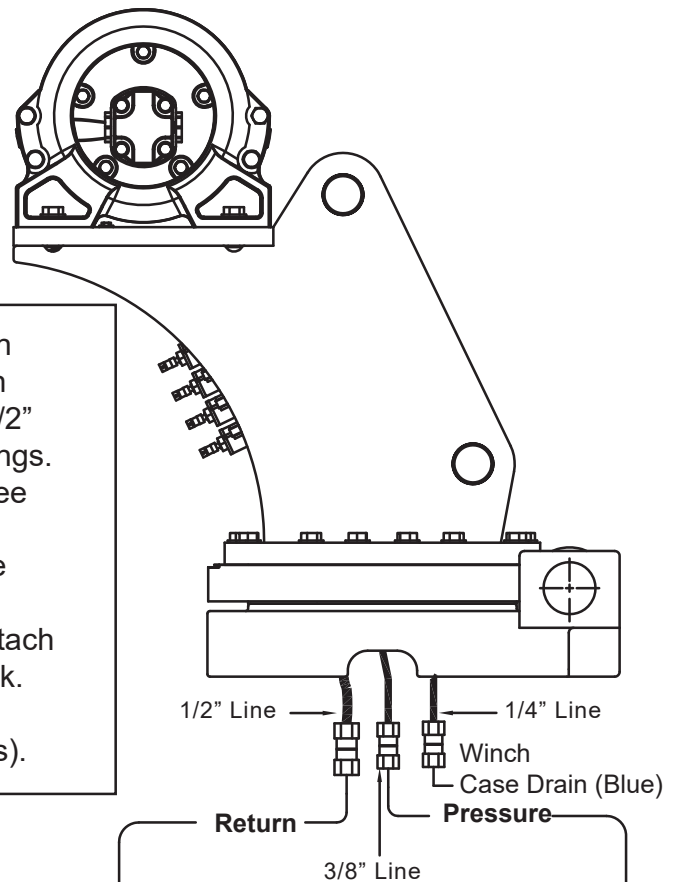

Winch Case Drain Installation

WARNING

Follow the instructions presented on this page. Failure to follow these instructions may result in death or serious injury.

Installing The Winch Case Drain

1. The winch case drain must run directly to the reservoir to ensure no back pressure in the line.
2. Use 1/4" hydraulic hose and fittings rated for a minimum of 300 psi.
3. Locate the winch case drain line at the bottom of the crane base as shown in Fig. 1 (Blue Hose).
Note: Verify the winch case drain is attached to the hose that is connected to the winch motor.
4. Attach one end of the winch case drain to 1/4" swivel fitting located in step 3.
5. Route the winch case drain hose directly to the reservoir.
6. Connect the second end of the winch case drain to unshared fitting on the top of the reservoir as shown in Fig 2.

Fig.1

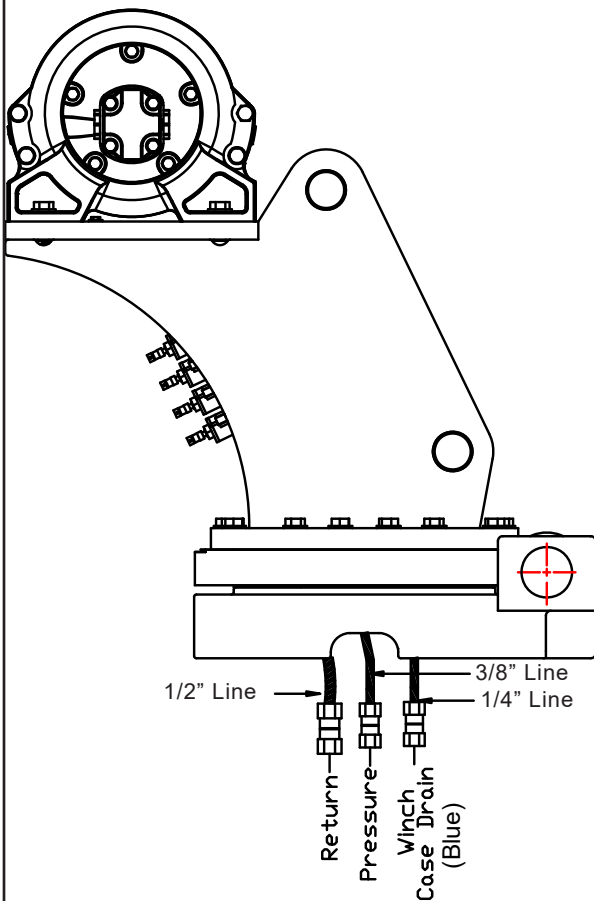
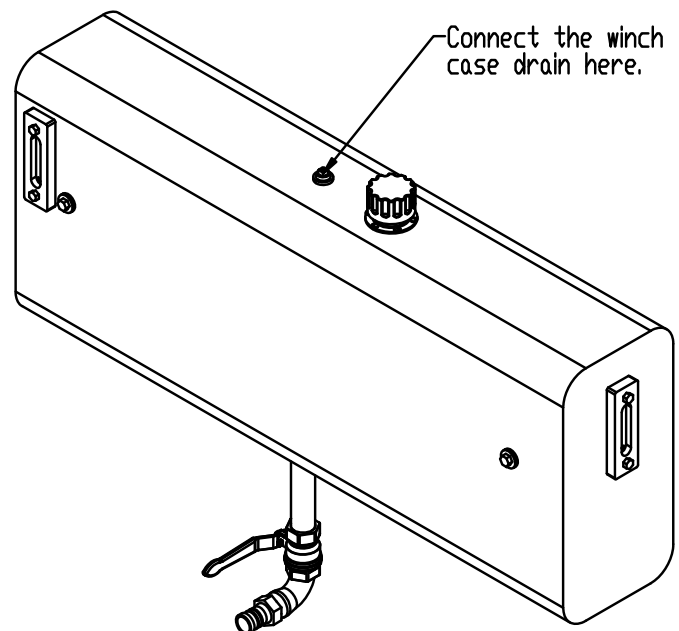
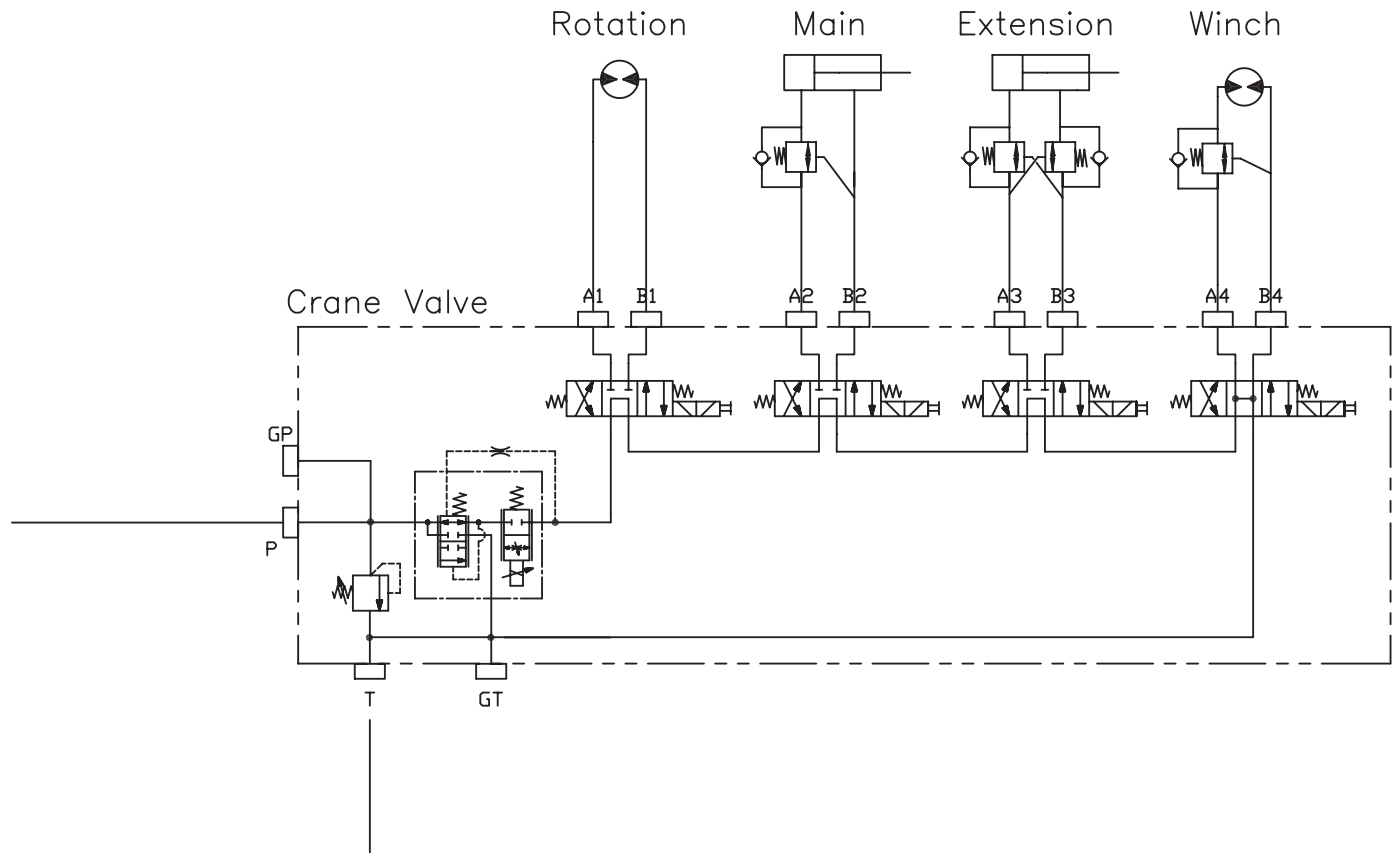

Fig. 2



Hydraulic System



Face Seal/O-Ring Size Chart

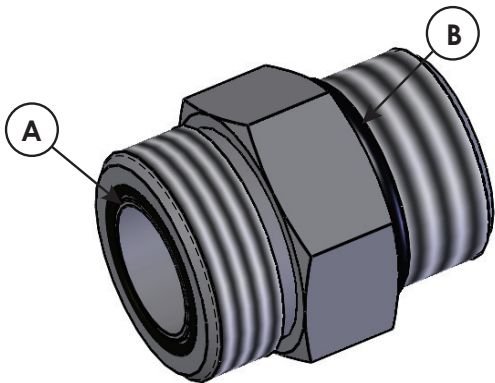

Hose Size	Fitting Size	Face Seal (A) Stellar® PN	O-ring Boss (B) Stellar® PN
1/4"	#4	C2027	D1245
3/8"	#6	C2028	D1246
1/2"	#8	C2029	D1247
5/8"	#10	32223	D1248
3/4"	#12	D1244	D1249
1"	#16		D1250

Stability Procedure

Definition of Stability for the Stellar Telescopic Crane Products:

A truck is stable until the load cannot be lifted off the ground with the winch, without tipping over the truck. Every Stellar crane installed must be tested for stability to determine the actual load capacity of the final truck package. The actual test data must be recorded and supplied with the truck at the time of in-service and should be kept with the truck at all times. The following procedure will test the truck package for stability and will provide a stability capacity chart. The load limit information shown on the stability capacity chart is formulated on 85% tipping.

Set Up:

1. Locate the truck on a test course in position for loading and engage travel brakes.
2. Set stabilizers so that they make contact with firm, level footing.
3. Operate the crane under partial load to assure operator proficiency and proper machine function.
4. Put the radio into Stability Test Mode:
 - A. Push the four crane function switches up and hold until the screen reads "STB" in the upper right corner (approximately 5 seconds.)



B. At this point, the crane will have enough capacity to handle the weight for the stability test.

C. The radio will timeout of stability mode after 30 minutes or when the E-Stop button is pushed.

NOTICE

The radio can only be put into stability mode five times. After that, the radio would have to be returned to Stellar to be reprogrammed to allow additional stability testing. All other radio functions will work properly even if stability mode is not available.

Stability Procedure Continued...

7621 Stability Data

Max Horizontal Reach: 250" (From the center of rotation to boom tip)

Boost Stability Test Weight: 2,530 lbs.

Non-Boost Stability Test Weight: 2,145 lbs.

Test Procedure

1. Rotate the crane into Zone 1 position.
2. With the crane fully retracted and the boom horizontal, winch the test weight off the ground.
Note: Keep weight within six inches of the ground at all times.
3. Extend the boom outward until full extension has been reached or until the truck becomes unstable (Again, use the winch to keep the weight within six inches of the ground.)
4. If the boom goes full extension without becoming unstable, the crane is termed stable for this zone and 100% can be written in the Zone 1 data box.
5. If the truck becomes unstable prior to going full extension, retract the boom until the truck becomes stable and measure the horizontal reach in this position (center of rotation to boom tip). This is the stable horizontal reach for this zone. Stable horizontal reach divided by Maximum horizontal reach multiplied by 100 equals the percentage of rated capacity for this zone. Use the following formula to determine the percentage of rated capacity:
6. Record this number in the data box for Zone 1. This is the revised capacity due to stability for this zone.
7. Repeat this procedure for each zone until the worksheet is completed.
8. This is the revised capacity based on stability of this package.

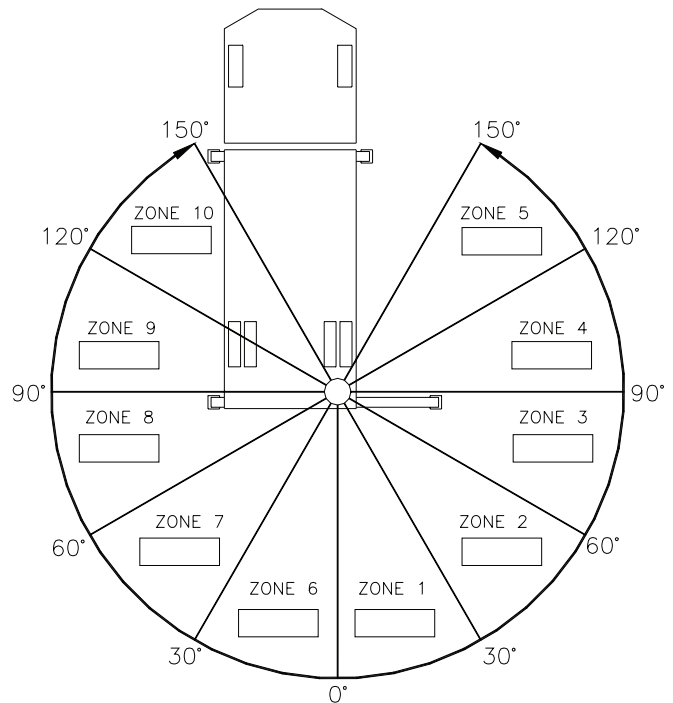

$$\frac{\text{Stable Horizontal Reach}}{\text{Max Horizontal Reach}} \times 100 = \text{Percentage of Rated Capacity}$$

Crane Load Level Indicator

Stellar® Cranes are shipped with a load level indicator that is used to determine if the truck is level (side to side) before using the crane to pick/move a load. This level should be installed in the isolated crane compartment of the body. If level indicator is missing or damaged, please contact Stellar Customer Support for a replacement.



PN 76483

Decal Placement - PN 117189

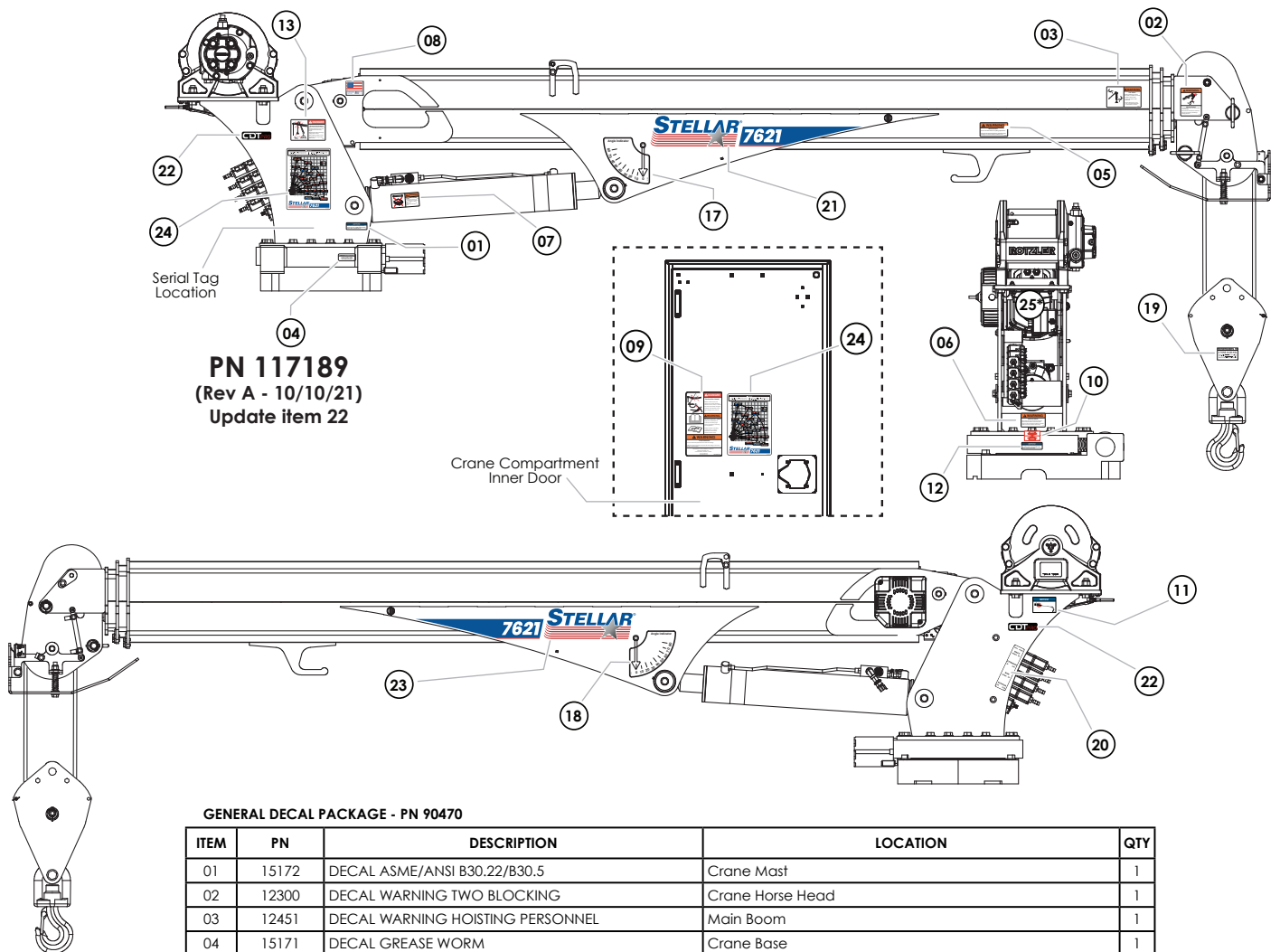

PN 117189
(Rev A - 10/10/21)
Update item 22

GENERAL DECAL PACKAGE - PN 90470

ITEM	PN	DESCRIPTION	LOCATION	QTY
01	15172	DECAL ASME/ANSI B30.22/B30.5	Crane Mast	1
02	12300	DECAL WARNING TWO BLOCKING	Crane Horse Head	1
03	12451	DECAL WARNING HOISTING PERSONNEL	Main Boom	1
04	15171	DECAL GREASE WORM	Crane Base	1
05	24712	DECAL WARNING STOW HOOK	Crane Boom above stow hook	1
06	25159	DECAL WARNING MANUAL OVERRIDES	Under Valve Bank	1
07	28256	DECAL WARNING OVERLOAD DEVICE	Main Cylinder	1
08	35234	DECAL STELLAR MADE IN THE USA	Main Boom	1
09	93936	DECAL SAFETY & SERV MECH BODY DOOR	Crane Compartment	1
10	4188	DECAL ROTATION ALIGNMENT	Crane Base	1
11	73929	DECAL PRESSURE WASH	Crane Mast	1
12	9188	DECAL ROTATE/GREASE	Crane Base	1
13	C1179	DECAL DANGER ELECTROCUTION SMALL	Crane Mast	1
14**	C4545	DECAL DANGER ELECTROCUTION LARGE	Four corners of the body/chassis	4
15**	C5910	DECAL STELLAR 4x9.5	Suggested: Rear body/tailgate	1
16**	C5911	DECAL STELLAR 2x4.5	Suggested: Side corners of body	3
17	D1196	DECAL ANGLE INDICATOR CS	Main Boom	1
18	D1197	DECAL ANGLE INDICATOR SS	Main Boom	1

7621 HSS DECAL PACKAGE - 117190

ITEM	PN	DESCRIPTION	LOCATION	QTY
19	116441	DECAL SNATCH BLOCK 5 TON	Snatch Block	1
20	41068	DECAL VB CONTROL MECH CRANE	On side of Crane Mast	1
21	117192	DECAL I.D. 7621 HSS PRE-MASKED CS	Main Boom (Curb Side)	1
22	122920	DECAL CDT PRO MAST	Crane Mast (Both Sides)	2
23	117191	DECAL I.D. 7621 HSS PRE-MASKED SS	Main Boom (Street Side)	1
24	118555	DECAL CAPACITY 7621 HSS	Main Boom and Crane Compartment	2
25*	118532	DECAL CNTRL ID 7621 V3 CDT PRO	CDT PRO ONLY - Valve controller inside mast	1
25*	124607	DECAL CNTRL ID 7621 V3 CDT PRO NB	CDT PRO NONBOOST ONLY - Valve controller inside mast	1

*For CDTpro™ equipped cranes, use PN 118532. For CDTprononboost™ equipped cranes, use PN 124607.

** Not shown.

This page left intentionally blank.

Chapter 3 - Assembly Drawings

Chapter Contents

Base Assembly - PN 50364	30
Base Assembly - PN 50364 Parts List	31
Gear Bearing - PN 47869.....	32
Gear Bearing - PN 47869 Parts List.....	33
Mast Assembly - PN 131786.....	34
Mast Assembly - PN 131786 Parts List.....	35
Winch - PN 107773.....	36
Winch - PN 107773 Parts List.....	37
Main Boom Assembly - PN 108542	38
Main Boom Assembly - PN 108542 Parts List	39
Extension Boom Assembly - PN 108547	40
Extension Boom Material List - PN 108547 Parts List	41
Extension Boom Material List - PN 108547 Parts List	42
Main Cylinder Assembly - PN 113682.....	44
Main Cylinder Assembly - PN 113682 Parts List.....	45
Extension Cylinder Assembly - PN 108684.....	46
Extension Cylinder Assembly - PN 108684 Parts List.....	47
Snatch Block Assembly - PN 56266.....	48
Snatch Block Assembly - PN 56266 Parts List.....	49
Wireless Remote Replacement Parts	50
Wireless Remote Replacement Parts List.....	51

Base Assembly - PN 50364

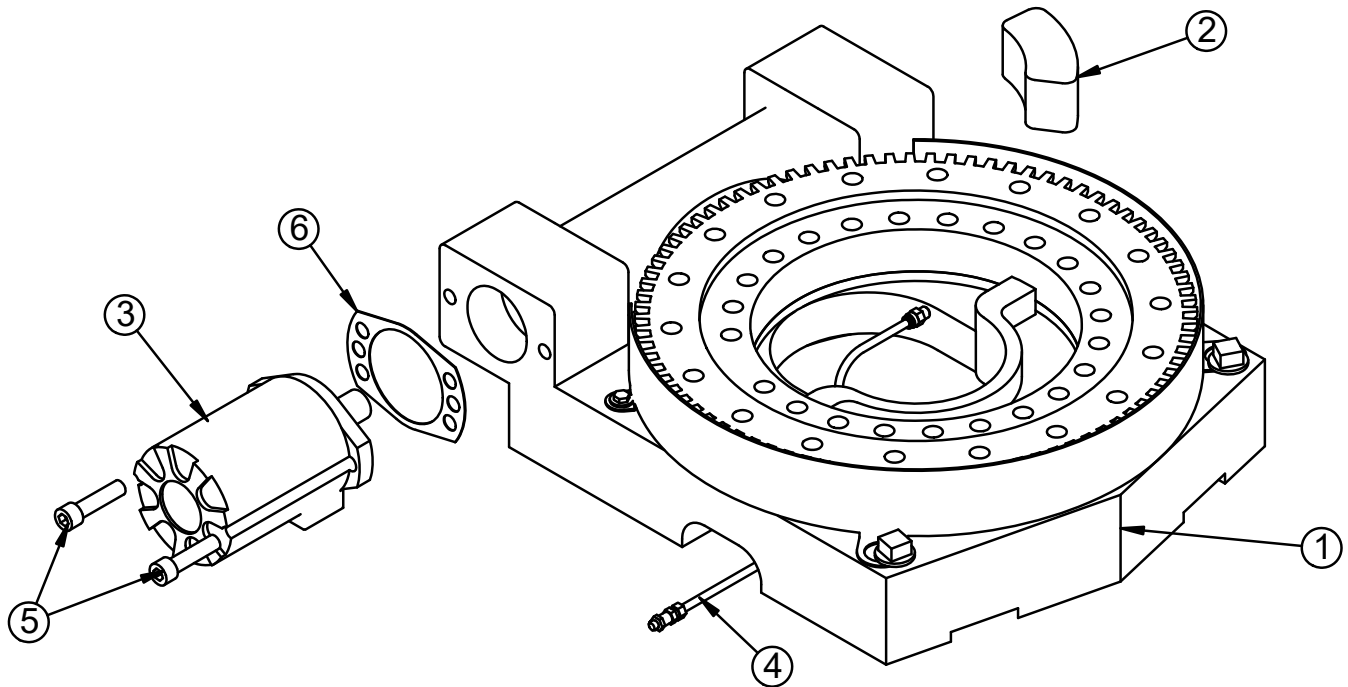

GASKET SHOWN AS REFERENCE

Base Assembly - PN 50364 Parts List

PN 50364			
ITEM	PART	DESCRIPTION	QTY
1	47869	BEARING SWING DRIVE CAST 6620 GEARTEK	1
2	11542	STOP 6620 400 SLIDE	1
3	C6069	MOTOR HYD ROSS MK080613AAAB	1
4	104018	HARDWARE KIT BASE ASM 30IN GREASE LINE	1
5	53495	CAP SCR 0.50-13X2.00 SH	2
6	21151	GASKET MOTOR 008-10056-1	1
REV. D			

NOTE:
ITEM 1 INCLUDES GUARD & GUARD FASTENERS.

Gear Bearing - PN 47869

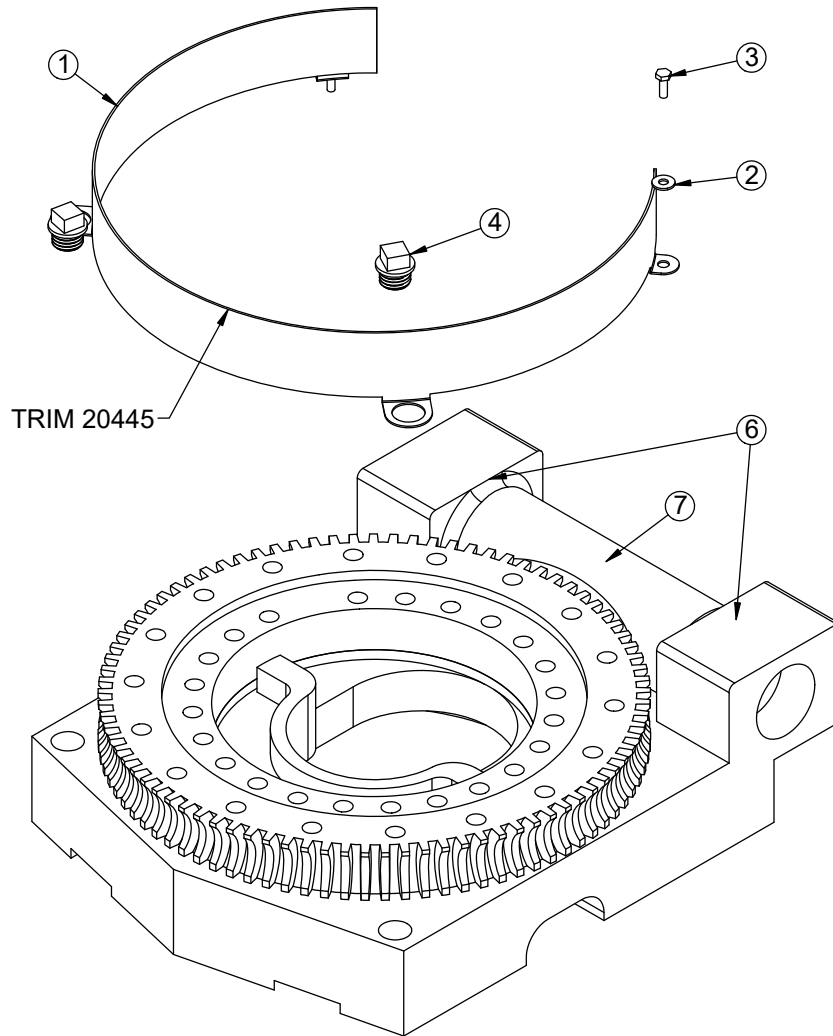

Gear Bearing - PN 47869 Parts List

PN 47869

ITEM	PART	DESCRIPTION	QTY
1	44551PC	Default	1
2	0340	WASHER 0.25 FLAT	2
3	0479	CAP SCR 0.25-20X0.75 HHGR5	2
4	13959	CAP SCR 1.00-8 X .63 PLASTIC	2
5	20445	TRIM EDGE 0.06X0.56 AL 0.63 BULB	42"
ITEM	PART	DESCRIPTION	QTY
6	55829	BEARING AND SEAL KIT 66/76 PERFECTION CAST	1
7	55827	WORM PERFECTION 66/76	1
ITEM	PART	DESCRIPTION	QTY
6	25896	BEARING AND SEAL KIT 10620 GP CAST	1
7	25895	WORM 10620 GP	1

REV. INTIAL RELEASE

Mast Assembly - PN 131786

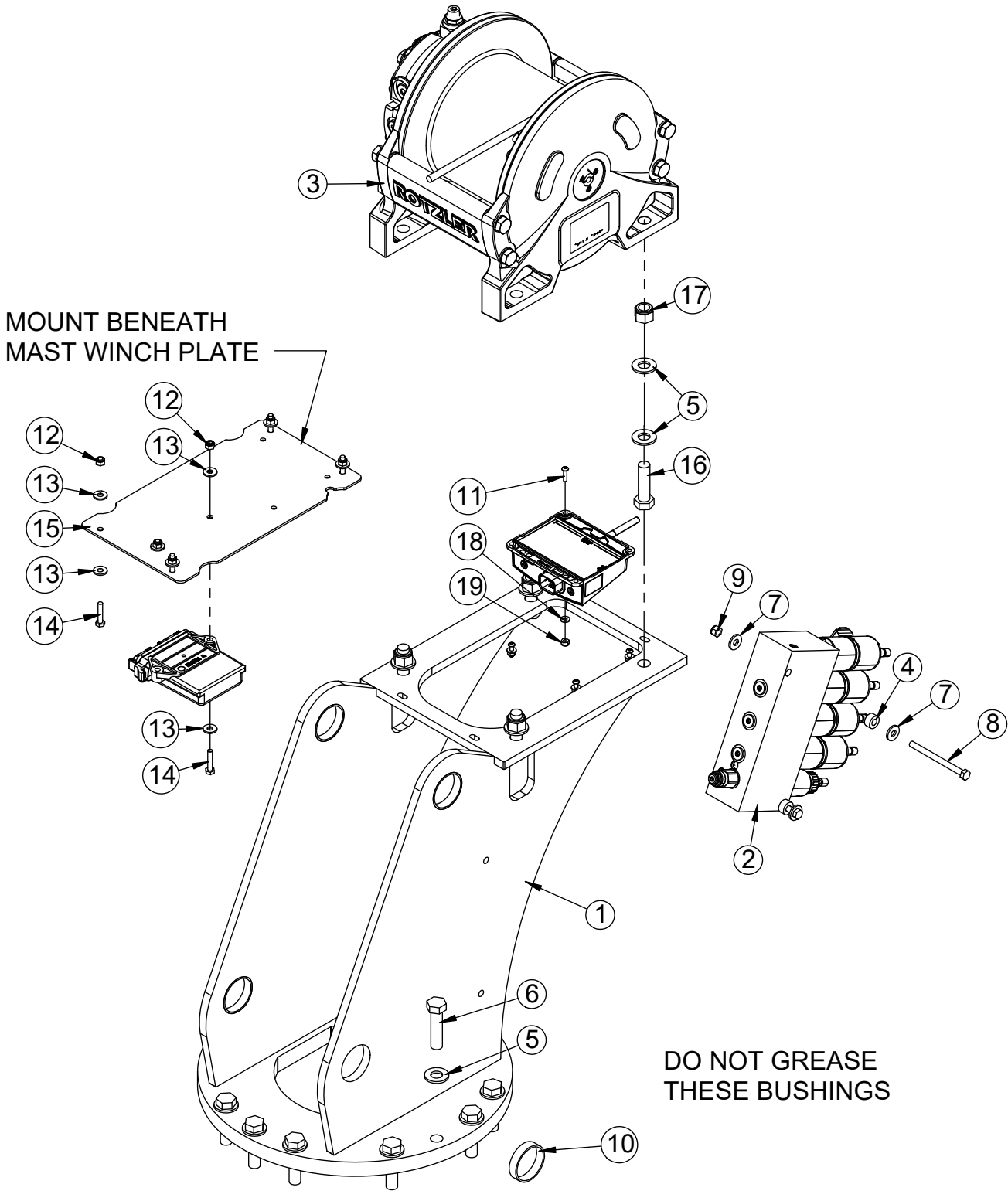

Mast Assembly - PN 131786 Parts List

PN 131786			
ITEM	PART	DESCRIPTION	QTY
1	106542	MAST 76 HSS	1
2	125254	VB 4 SECT W/PROP DELTROL 8GPM V2	1
3	107773	WINCH 3750 TI2CC W/100 FT ROPE	1
4	27813	COLLAR 0.38X0.75X0.38 UHMW	2
5	C5902	WASHER 0.63 SAE FLAT YELLOW GR8	22
6	66838	CAP SCR 0.63-11X2.50 HHGR8 W/RED PATCH	14
7	0343	WASHER 0.31 USS FLAT	4
8	0491	CAP SCR 0.31-18X4.00 HHGR5	2
9	0342	NUT 0.31-18 HHGR5 NYLOC	2
10	57594	BUSHING COMPOSITE 2.00X0.50	4
11	D0894	CAP SCR #10-24X0.75 BTNHD SS	4
12	0333	NUT 0.25-20 HHGR5 NYLOC	6
13	0340	WASHER 0.25 USS FLAT	12
14	0437	CAP SCR 0.25-20X1.25 HHGR5	6
15	101846	PLATE RADIO MNT MAST 76 HSS	1
16	84053	CAP SCR 0.63-11X2.25 HHGR8	4
17	24868	NUT 0.63-11 HHGR8 NYLOC	4
18	D0178	WASHER #10 SAE FLAT	4
19	26034	NUT #10-24 HH NYLOC	4
REV. INITIAL RELEASE			

NOTES:
HARDWARE KITS:
118557
118558

Winch - PN 107773

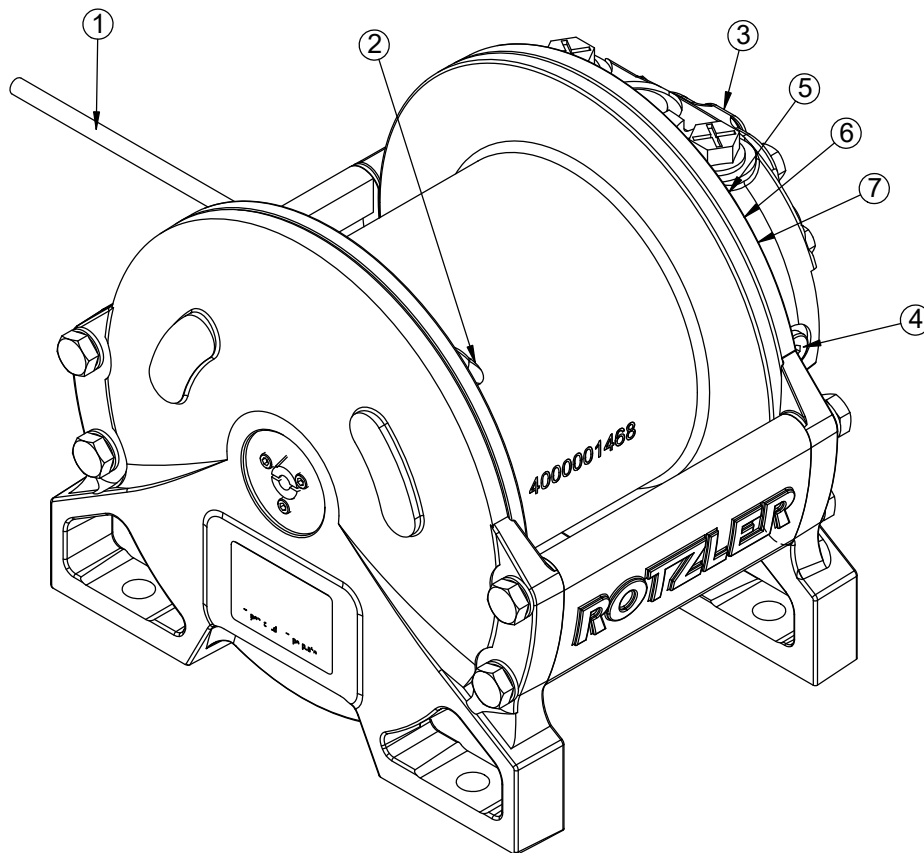

Winch - PN 107773 Parts List

PN 107773			
ITEM	PART	DESCRIPTION	QTY
1	13403	WIRE ROPE 3/8 6X31 IWRC-DGXIP 100FT	1
2	92074	WEDGE ROTZLER TH2/TI2	1
3	111286	MOTOR WINCH 3750 ROTZLER TI2-23	1
4	111287	VALVE COUNTERBALANCE ROTZLER TI2-23	1
5	106856	SEAL KIT WINCH DRUM ROTZLER TI2	1
6	106857	SEAL KIT WINCH BRAKE ROTZLER TI2	1
7	137956	SEAL KIT WINCH MOTOR CHANGE ROTZLER TI2	1
REV. A REQ831			

NOTES:

WHEN REPLACING MOTOR, ALSO USE KIT: 137956.

COUNTERBALANCE VALVE TORQUE SPEC: 30-35 FT-LB.

Main Boom Assembly - PN 108542

-TWO WASHERS BETWEEN SENSOR AND PLATE
-NO WASHER BETWEEN BOLT AND PLATE

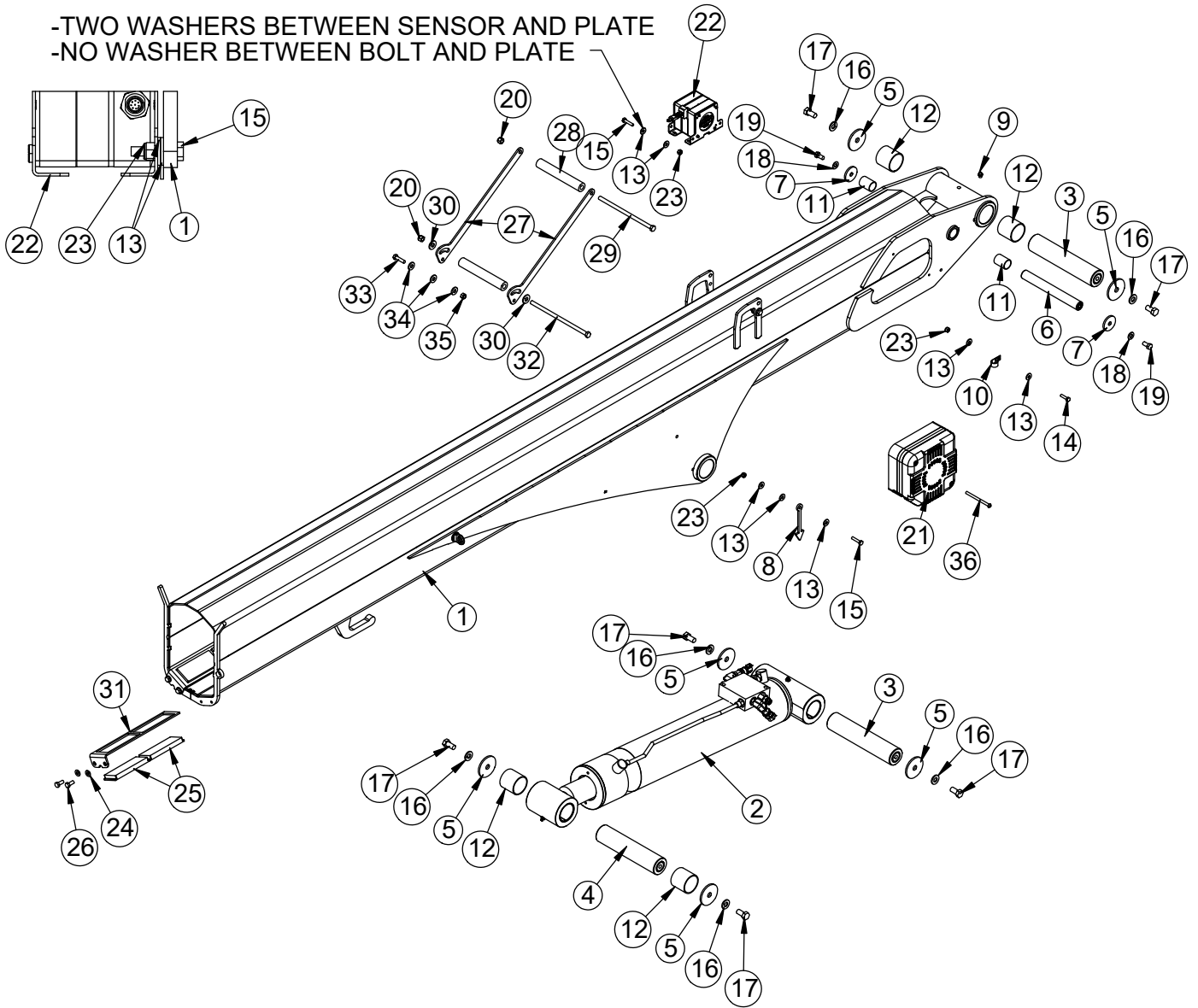

NOTES:
HARDWARE KITS:
 97628
 118559
 118867
 118868

Main Boom Assembly - PN 108542 Parts List

PN 108542			
ITEM	PART	DESCRIPTION	QTY
1	108543	INNER BOOM 7621 HSS	1
2	113682	CYLINDER ASM 4.50X22.50 76 HSS	1
3	26213CR	PIN 2.00X9.63 D&T ZC	2
4	9711CR	PIN 2.00X8.88 D&T ZC	1
5	9142	PIN CAP 0.56X2.50X0.19 YZ	6
6	107028CR	PIN 1.00X8.50 D&T ZC	1
7	9320	PIN CAP 0.44X1.75X0.19 YZ	2
8	102289	PLATE ANGLE INDICATOR 76 HSS BLACK	2
9	C1592	ZERK 1/8 NPT STRAIGHT	1
10	C0078	CLAMP 0.38 BLK VINYL	1
11	0068	BUSHING BPC16DXR24 1.00X1.50	2
12	4381	BUSHING BPC32DXR32 2.00X2.00	4
13	0340	WASHER 0.25 USS FLAT	12
14	0480	CAP SCR 0.25-20X1.00 HHGR5	1
15	0437	CAP SCR 0.25-20X1.25 HHGR5	4
16	D0790	WASHER 0.50 SAE FLAT YELLOW GR8	6
17	10172	CAP SCR 0.50-13X1.00 HHGR8	6
18	C6353	WASHER 0.38 SAE FLAT YELLOW GR8	2
19	9843	CAP SCR 0.38-16X0.75 HHGR8	2
20	0347	NUT 0.38-16 HHGR5 NYLOC	2
21	123760	CORD REEL 29FT 4 WIRE SEALED	1
22	110460	ENCODER BOOM VECTOR 6M CANOPEN	1
23	0333	NUT 0.25-20 HHGR5 NYLOC	5
24	5591	WASHER 0.31 SAE FLAT YELLOW GR8	4
25	107026	WEAR PAD INNER 76 HSS	4
26	0420	CAP SCR 0.31-18X0.75 HHGR5	4
27	109670	PLATE ROPE GUIDE 76 HSS SLOT BLACK	2
28	107776	SPACER ROPE GUIDE 76 HSS UHMW	2
29	90913	CAP SCR 0.38-16X8.00 HHGR5	1
30	0346	WASHER 0.38 USS FLAT	2
31	106801	PLATE WEAR PAD GUIDE INNER 76 HSS	2
32	87979	CAP SCR 0.38-16X8.50 HHGR5	1
33	0485	CAP SCR 0.31-18X1.25 HHGR5	2
34	0343	WASHER 0.31 USS FLAT	6
35	0342	NUT 0.31-18 HHGR5 NYLOC	2
36	66795	CAP SCR 0.25-20X3.50 BTNHD SS	2
REV. C			

Extension Boom Assembly - PN 108547

NOTE:
HARDWARE KITS:
118869
118870

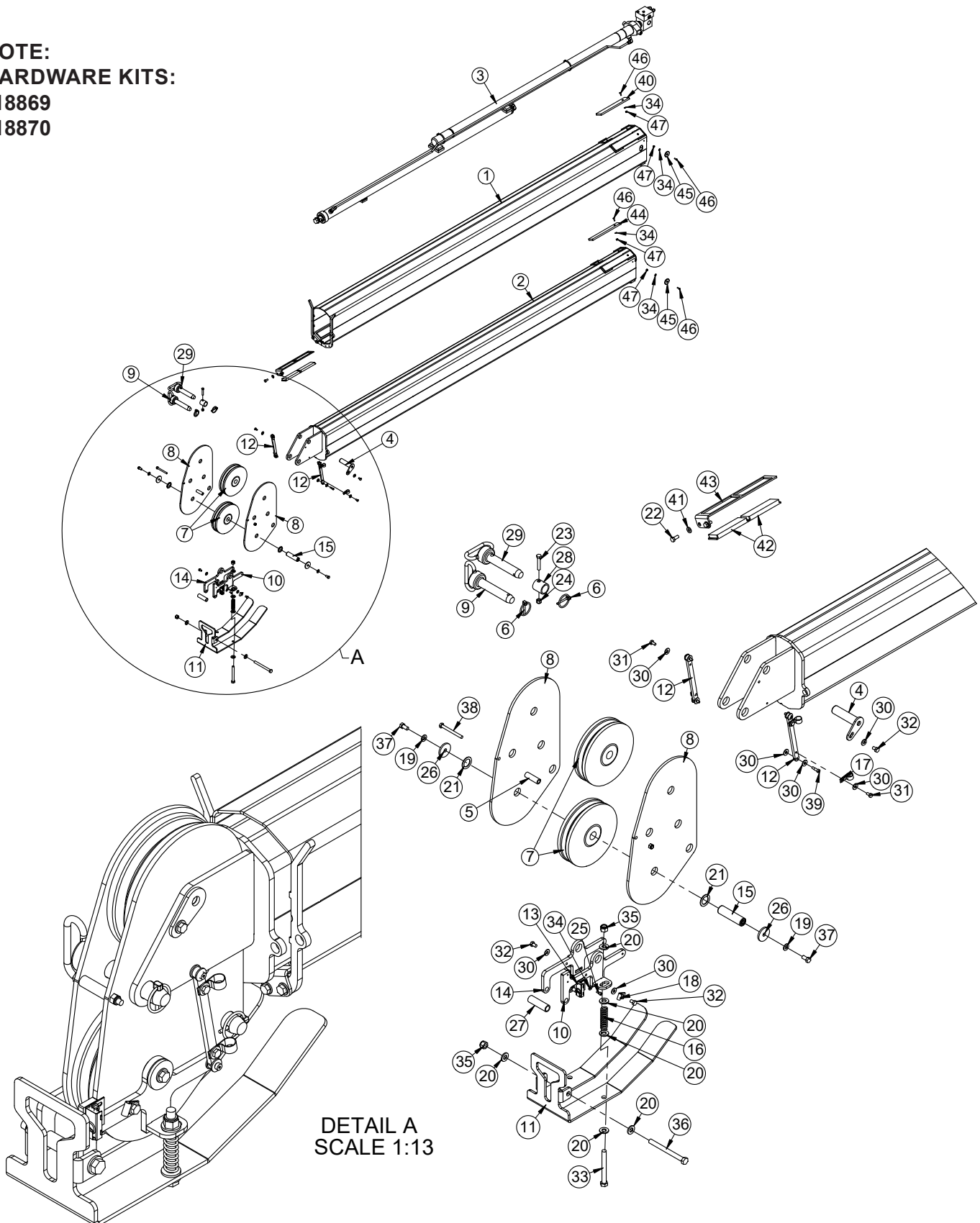

Extension Boom Material List - PN 108547 Parts List

PN 108547			
ITEM	PART	DESCRIPTION	QTY
1	108469	EXT BOOM 1ST 7621 HSS	1
2	108472	EXT BOOM 2ND 7621 HSS	1
3	108684	CYLINDER EXT ASM 7621 HSS	1
4	13399ZP	PIN TEAR DROP 1.00X3.81 ZC	1
5	27719	SPACER BOOM TIP 6620 UHMW	1
6	5753	PIN 0.19X1.56 LYNCH	2
7	13339	SHEAVE 7621 8.00 DIA .38R/1.88THK	2
8	106863	PLATE SHEAVE MOUNT 76 HSS PC BLACK	2
9	12824	PIN HITCH 1.00X4.50	1
10	122399	MNT CRADLE LH FS/CRADLE A2B 126 HSS YELLOW	1
11	106839	PLATE CRADLE A2B 76 HSS YELLOW	1
12	106982	PLATE LINK FS/CRADLE 76 HSS TAPPED YELLOW	2
13	35105	SWITCH LIMIT E1117-B9111-6C	1
14	122429	MNT CRADLE RH FS/CRADLE A2B 126 HSS YELLOW	1
15	106985CR	PIN 1.00X3.69 D&T	1
16	27710	SPRING ANTI 2 BLOCK CRADLE A2B	2
17	C0078	CLAMP 0.38 BLK VINYL	2
18	31279	CLAMP 0.31D 0.75W 0.40HL GALV BLK VINYL	1
19	C6353	WASHER 0.38 SAE FLAT YELLOW GR8	2
20	D0790	WASHER 0.50 SAE FLAT YELLOW GR8	10
21	0867	MACHY WASHER 1.00ID 14GA	2
22	0420	CAP SCR 0.31-18X0.75 HHGR5	4
23	0487	CAP SCR 0.31-18X1.75 HHGR5	1
24	0342	NUT 0.31-18 HHGR5 NYLOC	2
25	31132	CAP SCR #10-24X0.550 SH SS 18-8	2
26	9320	PIN CAP 0.56X3.50X.25	2
27	106986	PIPE 0.50X2.81 SCH40 YELLOW	1
28	106984	TUBE SPACER HITCH PIN 1.00X1.38 BLACK	1
29	45125	PIN HITCH 1.00 FORK KPCC	1
30	0340	WASHER 0.25 USS FLAT	15
31	0478	CAP SCR 0.25-20X0.50 HHGR5	4
32	0484	CAP SCR 0.31-18X0.50 HHGR5	3
33	0507	CAP SCR 0.50-13X4.50 HHGR5	2
34	D0178	WASHER #10 SAE FLAT	10
35	C6106	NUT 0.50-13 HHGR5 NYLOC	3
36	C1001	CAP SCR 0.50-13X5.50 HHGR5	1
37	9843	CAP SCR 0.38-16X0.75 HHGR8	2
38	12178	CAP SCR 0.31-18X3.25 HHGR5	1
39	106806	BOLT SHOULDER 0.25X0.50 0.25-20X0.38	4
40	106802	WEAR PAD 1ST EXT TOP 76 HSS	2
41	5591	WASHER 0.31 SAE FLAT YELLOW GR8	4

Extension Boom Material List - PN 108547 Parts List

PN 108547			
ITEM	PART	DESCRIPTION	QTY
42	107027	WEAR PAD 1ST EXT BOTTOM 76 HSS	4
43	106860	PLATE WEAR PAD GUIDE 76 HSS 1ST FRONT	2
44	106862	WEAR PAD 2ND EXT TOP 76 HSS	2
45	107029	WEAR PAD 0.19X1.50 ROUND	4
46	D0896	CAP SCR #10-24X0.75 FSHH SS	8
47	26034	NUT #10-24 HH NYLOC	8
REV. D			

NOTE:
HARDWARE KITS:
118869
118870

This page left intentionally blank.

Main Cylinder Assembly - PN 113682

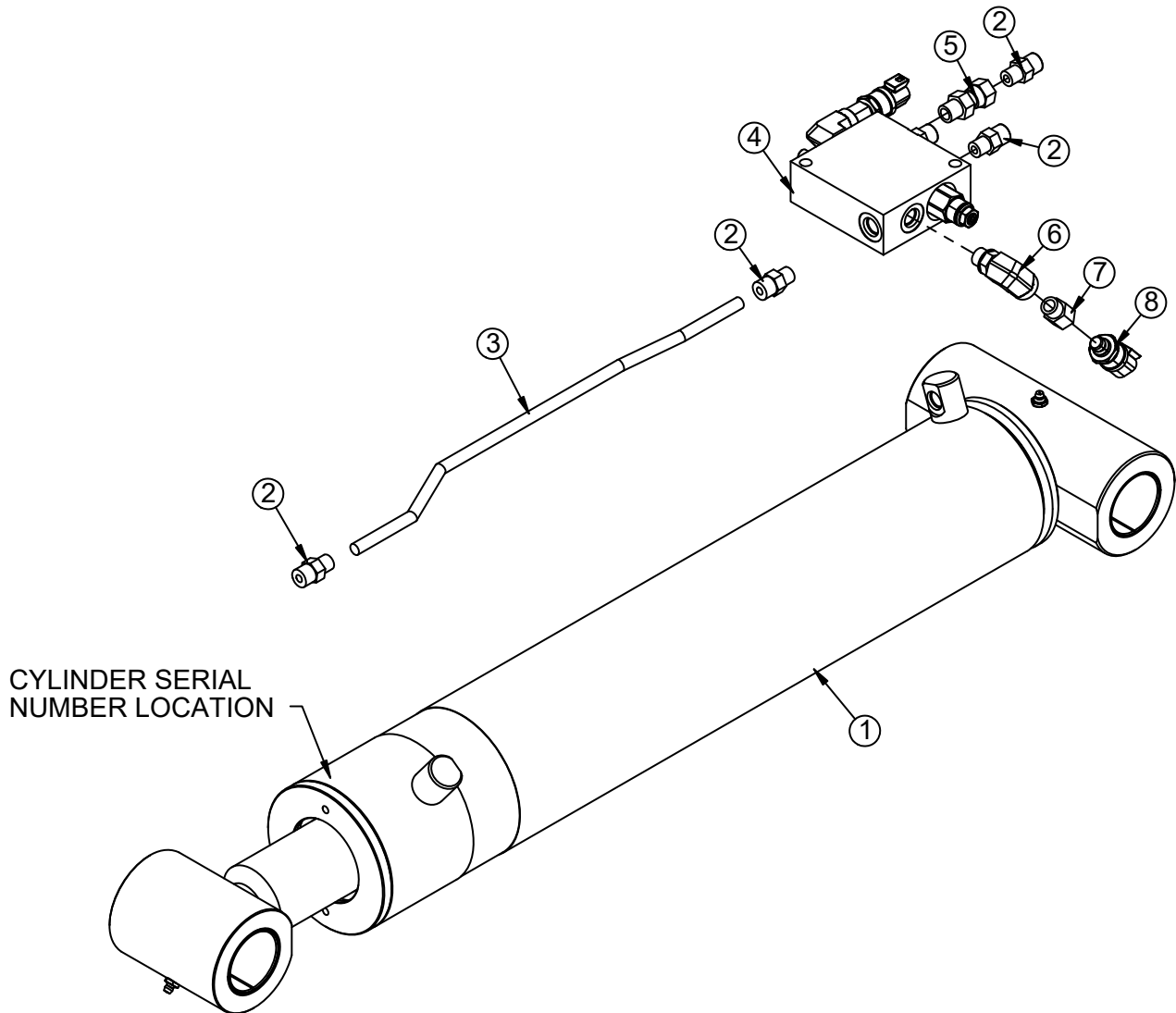

NOTES:

C-BALANCE VALVE: 113696

PRESSURE REDUCER VALVE: 35454

CYLINDER SEAL KITS:

BOB-91064

COL-129795

BMF-129796

BUSHING PART NUMBER: 4381

BUSHINGS INCLUDED IN: 71164

HARDWAR KIT: 98191

Main Cylinder Assembly - PN 113682 Parts List

PN 113682

ITEM	PART	DESCRIPTION	QTY
1	71164	CYLINDER 4.50X22.50	1
2	0279	FTG 6-6 MFS-MORB STRAIGHT	5
3	71460	TUBE ASM 0.38X16.72 12630 MAIN CYL ZC	1
4	113695	MANIFOLD SINGLE LA C'BAL W/PRV	1
5	33743	FTG 6-6 FFSS-MORB STRAIGHT	1
6	3861	FTG 6-6 MAORB-FORB 90	2
7	15111	FTG 6-4 MORB-FORB STRAIGHT REDUCER	2
8	108268	TRANSDUCER PRESSURE 0-5000PSI #4 SAE DT	2
REV. A			

NOTES:

C-BALANCE VALVE: 113696

PRESSURE REDUCER VALVE: 35454

CYLINDER SEAL KITS:

BOB: 91064

COL: 129795

BMF: 129796

BUSHING PART NUMBER: 4381

BUSHINGS INCLUDED IN: 71164

HARDWAR KIT: 98191

Extension Cylinder Assembly - PN 108684

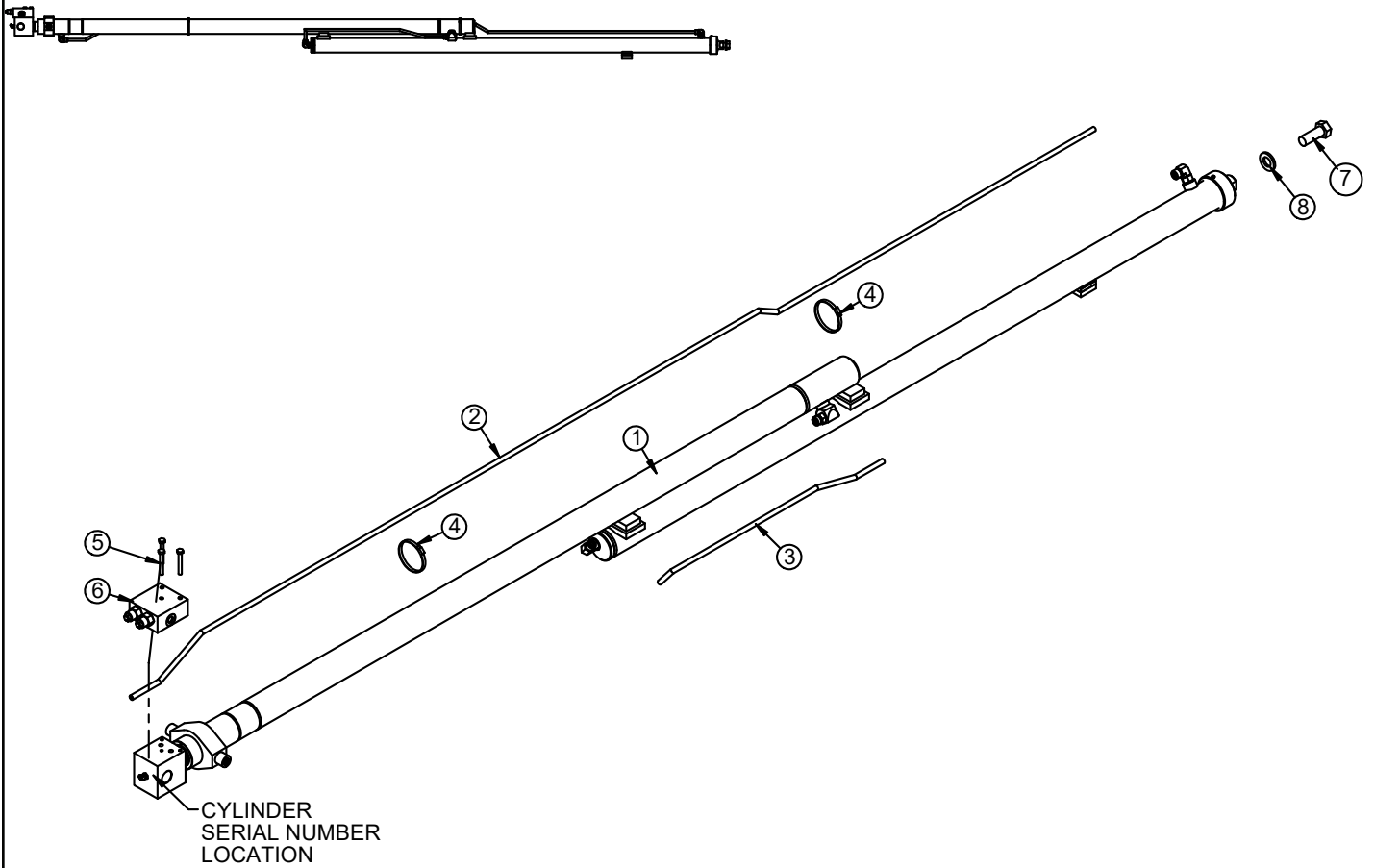

NOTES:

C-BALANCE VALVE: 9803

CYLINDER SEAL KITS:

BOB: 80503

COL: 128727

BMF: 129549

HARDWARE KIT: 118871

Extension Cylinder Assembly - PN 108684 Parts List

PN 108684			
ITEM	PART	DESCRIPTION	QTY
1	108685	CYLINDER EXT 7621 HSS 2 STAGE 2.0/2.0	1
2	108686	TUBE ASM 0.38X103.00 EXT CYL 7621 HSS	1
3	108687	TUBE ASM 0.38X22.66 EXT CYL 7621 HSS	1
4	D0655	HOSE CLAMP #36 WRM GEAR	2
5	0481	CAP SCR 0.25-20X2.00 HHGR5	3
6	106830	MANIFOLD ASM 76 HSS EXT CBBB-LJN-XVN CUSTOM	1
7	4543	CAP SCR 0.75-10X2.00 HHGR8	1
8	C6219	WASHER 0.75 SAE FLAT YELLOW GR8	1
REV. A			

NOTES:

C-BALANCE VALVE: 9803

CYLINDER SEAL KITS:

BOB: 80503

COL: 128727

BMF: 129549

HARDWARE KIT: 118871

Snatch Block Assembly - PN 56266

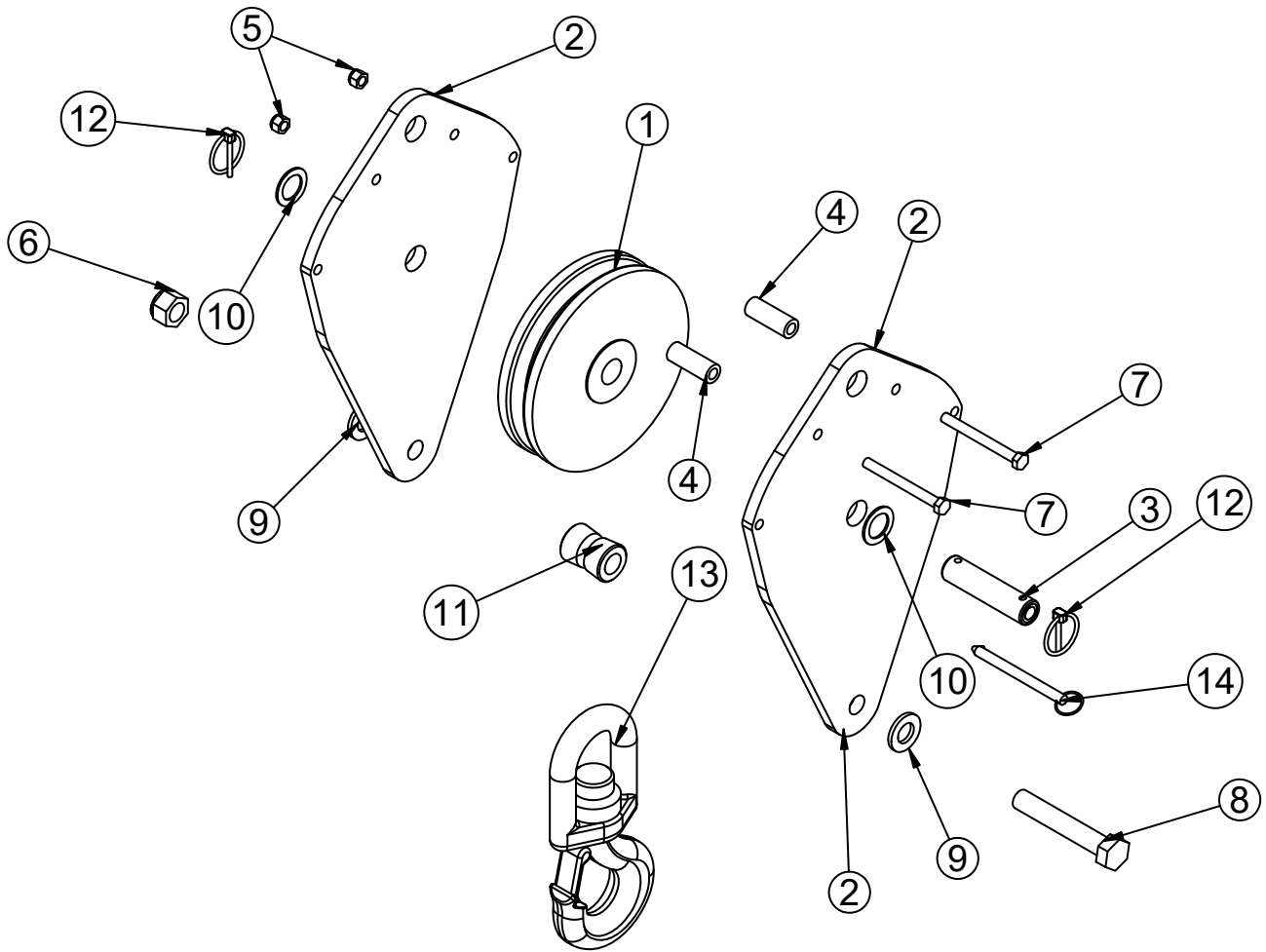

Snatch Block Assembly - PN 56266 Parts List

PN 56266			
ITEM	PART	DESCRIPTION	QTY
1	53263	PLATE SNATCH BLOCK 76/96/106/126	2
2	13339	SHEAVE 7621 8.00 DIA .38R/1.88THK	1
3	39874CR	PIN 1.00X4.06 COTTER ZC	1
4	39844CR	BUSHING V HOOK SS ZC	1
5	25831	HOOK 5 TON SWIVEL W/ BEARING	1
6	44643	COLLAR 0.44X0.75X2.00 ZINC COATED	2
7	0347	NUT 0.38-16 HHGR5 NYLOC	2
8	C0538	NUT 0.75-10 HHGR8 NYLOC	1
9	0532	CAP SCR 0.38-16X3.75 HHGR5	2
10	5841	CAP SCR 0.75-10X4.50 HHGR8	1
11	C6219	WASHER 0.75 SAE FLAT YELLOW GR8	2
12	0867	MACHY WASHER 1.00ID 14GA	2
13	5753	PIN 0.19X1.56 LYNCH	2
14	13436	PIN .38X4.00 QUICK RELEASE	1
REV. C			

NOTES:
HARDWARE KIT: 97639

Wireless Remote Replacement Parts

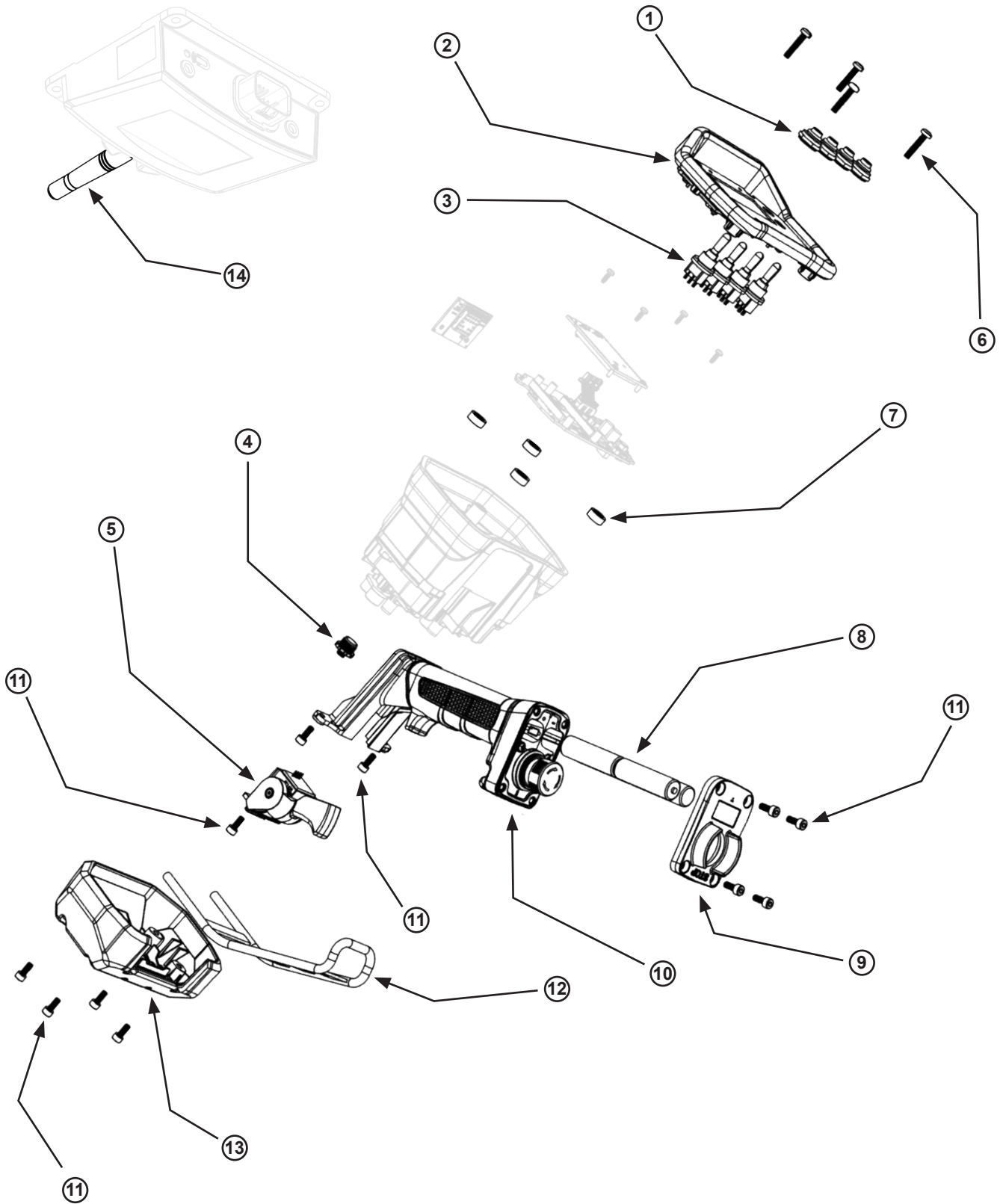

Wireless Remote Replacement Parts List

WIRELESS REMOTE REPLACEMENT PARTS		
ITEM	PART	DESCRIPTION
1	113574	SEALING BOOT TGL SWITCH HALF HEX M12
2	113560	FACEPLATE ASM MECH G6 PG
3	113561	TOGGLE SWITCH M-0-M G6 PG
4	125676	DUST CAP M12 MALE W/RBR LEASH G6 PG
5	113555	TRIGGER ASM G6 PG
6	125677	SCREW M4 X 20MM PAN HD TORX A4 SS
7	125675	DUST CAP M12 MALE W/RBR LEASH G6 PG
8	113552	BATTERY RECHRG AA NIMH
9	113558	BATTERY COVER G6 PG
10	113557	HANDLE ASM G6 PG
11	125678	SCREW M4 X 10MM SHCS BLK STL
12	113554	GUARD FRAME G6 PG
13	113556	SHROUD ASM G6 PG
14	113579	ANTENNA 2.4GHZ TNC 80MM FLEX BLUE



Subject to Change without Notification.
© 2024 Stellar Industries, Inc.